

Village of Carol Stream

BOARD MEETING

AGENDA

DECEMBER 19, 2011

All matters on the Agenda may be discussed, amended and acted upon

A. ROLL CALL AND PLEDGE OF ALLEGIANCE:

B. MINUTES: Approval of the Minutes of the December 5, 2011 Board Meeting.

C. AUDIENCE PARTICIPATION & PUBLIC HEARINGS:

D. SELECTION OF CONSENT AGENDA:

If you are here for an item which is added to the consent agenda and approved, the Village Board has acted favorably on your request.

E. BOARD AND COMMISSION REPORTS:

1. PLAN COMMISSION:

- a. #11251 – Village of Carol Stream – 500 N. Gary Avenue
Text Amendments – Zoning Code

RECOMMENDED APPROVAL WITH MINOR REVISIONS (7-0)

Request for approval of text amendments giving staff the authority to approve building permits for business improvements involving exceedingly minor items without needing to require that the business owner obtain approval through the zoning hearing process.

- b. #11305 – Windfall Group – 1175 N. Gary Ave
Gary Avenue Corridor Review

Minor Amendments to Planned Unit Development Plan

APPROVED SUBJECT TO CONDITIONS (7-0)

Variations – Sign Code

RECOMMENDED APPROVAL SUBJECT TO CONDITIONS (7-0)

Zoning approvals for modifications to the approved landscape plan and for modifications to the building and signage to accommodate Savers, the new anchor tenant.

F. OLD BUSINESS:

G. STAFF REPORTS & RECOMMENDATIONS:

1. Contract Amendment Request- *Baxter & Woodman requests a contract amendment to the Sludge Aeration Energy Efficiency Project by an additional \$41,855.20 to cover unforeseen expenses associated with the grant-funded installation of an energy-efficient turbo blower at the WRC that included needed electrical improvements, concrete work, blower valve relocation and the purchase of a standard harmonic filter.*

Village of Carol Stream

BOARD MEETING

AGENDA

DECEMBER 19, 2011

All matters on the Agenda may be discussed, amended and acted upon

2. Recommendation to Award a Contract for Construction of a Sodium Hypochlorite Delivery System at the WRC. *This project was recently re-bid following rejection of bids by the Village in November due to technicalities.*

H. ORDINANCES:

1. Ordinance No. _____, Authorizing the Ceding of Private Activity Bonding Authority. *The Village receives an annual allocation of bonding authority which can be used as an economic development tool to sponsor tax exempt financing for certain qualified private development projects. The Village previously reserved its 2011 volume cap totaling \$3,803,895 on April 18, 2011. The Upper Illinois River Valley Development Authority (UIRVDA) has requested the use of the Village's 2011 volume cap for use in projects under its jurisdiction. If ultimately used to finance a project, the Village will receive a transfer fee of 1% of bonds issued, to a maximum of \$38,039. As there are presently no qualifying local projects or requests identified, the recommendation is to cede the 2011 volume cap to UIRVDA.*
2. Ordinance No. _____, Amending Chapter 11 (Intoxicating Liquors), Article 2 (Alcoholic Liquor Dealers), Sections 11-2-2 and 11-2-7 Creating a New Class O, Bring Your Own Liquor License Classification. *An ordinance providing for licensing of establishments allowing patrons to bring alcohol purchased elsewhere in for consumption on site.*
3. Ordinance No. _____, Amending Chapter 16 of the Municipal Code of the Village of Carol Stream (Zoning Code). *See E1a.*
4. Ordinance No. _____, Amending Chapter 14 (General Offenses), Article 2 (Offenses Against Persons), Adding Sections 14-2-32 (Drug Paraphernalia). *The Police Department requests the Village Board to adopt an ordinance banning the use and possession of drug paraphernalia.*
5. Ordinance No. _____, Amending the Code of Ordinances of the Village of Carol Stream with Respect to Synthetic Alternative Drugs. *The Police Department requests that the Village Board adopt the Synthetic Alternative Drugs ordinance banning the sale, delivery, possession and use of these products within the Village of Carol Stream.*

Village of Carol Stream

BOARD MEETING

AGENDA

DECEMBER 19, 2011

All matters on the Agenda may be discussed, amended and acted upon

6. Ordinance No. _____, Amending Section 8-1-2, Penalties and Related Provisions of the Carol Stream Code of Ordinances. *The Police Department requests the Village Board adopt an amendment to Section 8-1-2, Penalties and Related Provisions, of the Carol Stream Code of Ordinances to mirror State Statute fine amounts.*

I. RESOLUTIONS:

1. Resolution No. _____, For Meeting the National Objective Under the Community Development Block Grant (CDBG) Program of a Community Development Need Having a Particular Urgency. *This resolution is to confirm that the Klein Creek Flood Plain Structure Buyout Project in the application for CDBG disaster recovery funding under the CDBG Disaster Recovery "IKE" Property Buyout Program meets the national objective under the CDBG Program of meeting a community development need having a particular urgency.*
2. Resolution No. _____, Declaring Surplus Property Owned by the Village of Carol Stream. *The Public Works Department has identified several items that are no longer useful or needed including radios, two trucks and a copier.*

J. NEW BUSINESS:

1. Request from College of DuPage at 500 N. Kuhn Road for review and approval of proposed signage improvements. *Under the terms of the agreement executed in 2001 between the Village, COD and the Carol Stream Fire Protection District, Village approval is required for the signage improvements, but no building or zoning permit is required.*
2. Social Media – *Request to Establish a Facebook Page for the 2012 Carol Stream Concerts and Town Center Events.*
3. Approval for Annual Raffle License – American Legion Post 76. *American Legion Post 76 requests approval for a 2012 annual raffle license. The Legion has advised their application will be submitted on Monday in advance of the meeting and will then be on file in the Clerk's office. Approval is subject to receiving required documentation in satisfactory format by December 31, 2011.*

Village of Carol Stream

BOARD MEETING

AGENDA

DECEMBER 19, 2011

All matters on the Agenda may be discussed, amended and acted upon

K. PAYMENT OF BILLS:

1. Regular Bills:
2. Addendum Warrants:

L. REPORT OF OFFICERS:

1. Mayor: - Cancellation of January 2, 2012 Village Board Meeting.
 - Rescheduling of January 16, 2012 Village Board Meeting to
 Tuesday, January 17, 2012.
2. Trustees:
3. Clerk: - Receipt of 2012 Schedule of Meetings
4. Treasurer's Report: Revenue/Expenditure Statement and Balance
 Sheet, Month Ending November 30, 2011.

M. EXECUTIVE SESSION:

1. Collective Negotiating Matters.
2. Continued Employment of a Specific Employee.

N. ADJOURNMENT:

LAST ORDINANCE: 2011-12-41 LAST RESOLUTION: 2563

NEXT ORDINANCE: 2011-12-42 NEXT RESOLUTION: 2564

**REGULAR MEETING OF THE MAYOR AND BOARD OF TRUSTEES
Gregory J. Bielawski Municipal Center, Carol Stream, DuPage County, IL**

December 5, 2011

Mayor Saverino called the Regular Meeting of the Board of Trustees to order at 8:00 p.m. and directed Village Clerk Beth Melody to call the roll.

Present: Mayor Frank Saverino, Sr. and Trustees Mary Frusolone,
Greg Schwarze, Matt McCarthy & Pam Fenner
Absent: Trustees Tony Manzzullo & Don Weiss

Also Present: Village Manager Joe Breinig, Assistant Village Manager Bob Mellor and Village Attorney, Jim Rhodes

MINUTES:

Trustee McCarthy moved and Trustee Fenner made the second to approve the Regular and Special Board Meeting Minutes of November 21, 2011. The results of the roll call vote were as follows:

Ayes: 3 Trustees, Schwarze, McCarthy and Fenner
Nays : 0
Abstain: 1 Trustee Frusolone
Absent: 2 Trustees Manzzullo & Weiss

AUDIENCE PARTICIPATION AND PUBLIC HEARINGS:

Carol Stream Rotary Club Christmas Sharing Donation: Carol Stream Rotary members Jane Hodgkinson, Ann Kennedy, Greg Schwarze, Luanne Newman and Bob McNees presented check to the Carol Stream Christmas Sharing Program.

Carol Stream Rotary Club Exchange Student Introduction: Carol Stream Rotary introduced Ecuadorian exchange student Sue Bastidas and exchanged Village of Carol Stream and Ecuadorian flags.

CONSENT AGENDA:

Trustee Schwarze moved and Trustee Fenner made the second to establish a Consent Agenda for this meeting. The results of the roll call vote were:

Ayes: 4 Trustees Frusolone, Schwarze, McCarthy and Fenner
Nays : 0
Absent: 2 Trustees Manzzullo & Weiss

Trustee McCarthy moved and Trustee Schwarze made the second to place the following items on the Consent Agenda established for this meeting.

The results of the roll call vote were as follows:

Ayes: 4 Trustees Frusolone, Schwarze, McCarthy and Fenner
 Nays : 0
 Absent: 2 Trustees Manzzullo & Weiss

1. Approval to waive the competitive bidding process and award contracts to Aqua-Aerobic Systems for purchase of filtration plates and other materials at a total cost of \$36,722.78; and, NWTs for plate removal and installation (\$29,430.50)
2. Approval to Waive Competitive Bidding Process and Purchase Replacement Water Meters from Midwest Meter, Inc., in the amount of \$68,175.00
3. Approval to Purchase Police Squad Vehicles under the Southwest Conference of Mayors Cooperative Bid
4. Ordinance No. 2011-12-37, Designating the Village of Carol Stream North Avenue and Schmale Road Tax Increment Financing District Redevelopment Project Area
5. Ordinance No. 2011-12-38, Approving the Village of Carol Stream North Avenue and Schmale Road Tax Increment Financing District Redevelopment Project Area Redevelopment Plan and Project
6. Ordinance No. 2011-12-39, Adopting Tax Increment Financing for the Village of Carol Stream North Avenue and Schmale Road Tax Increment Financing District
7. Ordinance No. 2011-12-40, Amending Section 13-3-13 of the Village Code Pertaining to Water and Sewer Rates
8. Ordinance No. 2011-12-41, for the Levy and Assessment of Taxes in the Amount of \$3,431,500 for the Fiscal Year Beginning May 1, 2011 and Ending April 30, 2012, of the Village of Carol Stream, DuPage County, Illinois
9. Resolution No. 2563, Declaring Surplus Property Owned by the Village of Carol Stream
10. Request from Outreach Community Ministries (OCM) for License Agreement
11. Expiration of Intergovernmental Agreement-Development and Ownership of Hampe Park
12. Payment of Regular & Addendum Warrant of Bills

Trustee Frusolone moved and Trustee Fenner made the second to approve the Consent Agenda for this meeting by Omnibus Vote. The results of the roll call vote were as follows:

Ayes: 4 Trustees Frusolone, Schwarze, McCarthy and Fenner
 Nays : 0
 Absent: 2 Trustees Manzzullo & Weiss

The following are brief descriptions of those items approved on the Consent Agenda for this meeting.

Approval to waive the competitive bidding process and award contracts to Aqua-Aerobic Systems for purchase of filtration plates and other materials at a total cost of \$36,722.78; and, NWTS for plate removal and installation (\$29,430.50):

The Village Board approved the staff request to waive the competitive bidding process and award contracts to Aqua-Aerobic Systems for purchase of filtration plates and other materials at a total cost of \$36,722.78 and NWTS for plate removal and installation (\$29,430.50).

Approval to Waive Competitive Bidding Process and Purchase Replacement Water Meters from Midwest Meter, Inc., in the amount of \$68,175.00:

The Public Works Department is initiating a program to replace 1,100 water meters over 20 years old. This purchase would cover the first phase of about 300 meters. The Village Board approved the staff recommendation to waive the competitive bidding process and to purchase replacement water meters from the sole source for Badger meters, Midwest Meter, Inc., in the amount of \$68,175.00.

Approval to Purchase Police Squad Vehicles under the Southwest Conference of Mayors Cooperative Bid:

The Village Board approved the Police Department recommendation to purchase five (5) squad vehicles under the Southwest Conference of Mayors Cooperative bid in the amount of \$124,995.

Ordinance No. 2011-12-37, Designating the Village of Carol Stream North Avenue and Schmale Road Tax Increment Financing District Redevelopment Project Area:

The Village Board approved Ordinance No. 2011-12-37, designating the Village of Carol Stream North Avenue and Schmale Road Tax Increment Financing District Redevelopment Project Area.

Ordinance No. 2011-12-38, Approving the Village of Carol Stream North Avenue and Schmale Road Tax Increment Financing District Redevelopment Project Area Redevelopment Plan and Project:

The Village Board passed Ordinance No. 2011-12-38, approving the Village of Carol Stream North Avenue and Schmale Road Tax Increment Financing District Redevelopment Project Area Redevelopment Plan and Project.

Ordinance No. 2011-12-39, Adopting Tax Increment Financing for the Village of Carol Stream North Avenue and Schmale Road Tax Increment Financing District:

The Village Board approved Ordinance No. 2011-12-39, adopting Tax Increment Financing for the Village of Carol Stream North Avenue and Schmale Road Tax Increment Financing District.

Ordinance No. 2011-12-40, Amending Section 13-3-13 of the Village Code Pertaining to Water and Sewer Rates:

Trustee McCarthy stated this rate increase is a direct pass-through of the City of Chicago rate increase. This ordinance increases the standard billing rate for water services from \$4.09 to \$4.78 per 1,000 gallons metered. The \$0.69 rate increase is a direct pass-through of the Village's additional cost of purchasing water through the

DuPage Water Commission and is in response to rate increases recently approved by the City of Chicago. The Village Board approved Ordinance No. 2011-12-40, amending Section 13-3-13 of the Village Code pertaining to water and sewer rates. The new rates will take effect January 1, 2012.

Ordinance No. 2011-12-41, for the Levy and Assessment of Taxes in the Amount of \$3,431,500 for the Fiscal Year Beginning May 1, 2011 and Ending April 30, 2012, of the Village of Carol Stream, DuPage County, Illinois:

This ordinance represents the property tax levy request of the Carol Stream Public Library for 2011 which will be collected in 2012. The Village Board is required to approve the tax levy request of the Library Board based on how the Library is organized under Illinois statutes. The Village Board approved Ordinance No. 2011-12-41, for the Levy and Assessment of Taxes in the Amount of \$3,431,500 for the Fiscal Year Beginning May 1, 2011 and Ending April 30, 2012, of the Village of Carol Stream, DuPage County, Illinois.

Resolution No. 2563, Declaring Surplus Property Owned by the Village of Carol Stream:

The Village Board approved the Police Department request to have five (5) vehicles that were awarded to the Village via seizure laws, declared surplus property, four (4) to be sold on EBay and one to be donated to the Fire Protection District for training.

Request from Outreach Community Ministries (OCM) for License Agreement:

The Village Board approved a request from OCM to enter into a license agreement with the Village of Carol Stream to allow use of Village property adjacent to the OCM building at 345 S. President Street for improved handicapped accessibility to their building.

Expiration of Intergovernmental Agreement-Development and Ownership of Hampe Park:

The Village Board received the staff report on the expiration of the Intergovernmental Agreement-Development and Ownership of Hampe Park and decided to take no action regarding a further agreement governing the use of Hampe Park.

Regular Bills and Addendum Warrant of Bills:

The Village Board approved the payment of the Regular Bills dated December 5, 2011 in the amount of \$176,216.97.

The Village Board approved the payment of the Addendum Warrant of Bills from November 22, 2011 – December 5, 2011 in the amount of \$695,845.98.

Non-Consent Agenda Items:

Electric Aggregation:

Staff provided a report to the Village Board which included municipal aggregation survey results and comments from neighboring communities as well as information on the various program options and associated community benefits to promoting deregulated electric supply for Carol Stream electric customers. The Village Board decided not to pursue electric aggregation and directed staff to provide energy saver program information to Village residents and small businesses.

Report of Officers:

Trustee Frusolone provided an update on the disaster committee and read the mission statement and goals of the committee. The emphasis of the committee is to provide education and planning information to residents. Trustee Frusolone introduced the 5 disaster committee members to the Village Board. Sample copies of disaster preparedness information packets were distributed to the Village Board. Over 300 information packets were distributed to residents along Klein and Thunderbird Creeks by the committee and volunteers on Saturday morning. The committee has also established a disaster information website at <http://www.carolstreamdisaster.com> and also maintains a [Facebook](#) page. She thanked Accurate Office Supply for their generous donation of envelopes and stationary and Starbucks for their coffee donation.

Trustee Fenner commented that the tax levy ordinance on tonight's agenda was required to be passed by the Village on behalf of the Carol Stream Library and is not for Village purposes.

Trustee Schwarze thanked DuPage County Board member Dirk Enger for all his hard work representing the Village of Carol Stream. He encouraged everyone to shop and purchase products in Carol Stream when possible. Assistant to the Village Manager Christopher Oakley provided a brief update on the Shop Carol Stream program and commented that the first business signed-up for the program on Friday.

Trustee McCarthy encouraged parents to pay attention to synthetic marijuana products such as K2, Spice, bath salts and incense being use by kids which can have bad effects on their health. Several deaths have been linked to its use and parents need to find out more about its use by young people. He thanked everyone who helped with the tree lighting ceremony on Friday. He reminded residents that there is still time to donate to or help out with the Christmas Sharing program which provides food and toys to needy families in Carol Stream.

Village clerk Melody reminded everyone, in the absence of Trustee Manzzullo, to pray for our troops.

Mayor Saverino stated that effective January 1, 2012 synthetic marijuana products will be illegal in Illinois and the sale of it will be classified as a felony. He reminded everyone about the Christmas Sharing program and that there were 236 families already signed-up to receive donations. Food distribution will take place at Lutheran Church of the Master. He thanked Joe Cotton Ford for all his support of the Christmas Sharing program.

12-05-2011 VB

At 8:55 p.m. Trustee McCarthy moved and Trustee Schwarze made the second to adjourn the meeting. The results of the roll call vote were as follows:

Ayes:	4	Trustees Frusolone, Schwarze, McCarthy and Fenner
Nays :	0	
Absent:	2	Trustees Manzzullo & Weiss

FOR THE BOARD OF TRUSTEES

Frank Saverino, Sr., Mayor

Beth Melody, Village Clerk

**Regular Meeting – Plan Commission/Zoning Board of Appeals
Gregory J. Bielawski Municipal Center, DuPage County, Carol Stream, Illinois**

All Matters on the Agenda may be Discussed, Amended and Acted Upon

December 12, 2011

Chairman David Michaelson called the Regular Meeting of the Combined Plan Commission/Zoning Board of Appeals to order at 7:30 p.m. and directed Secretary Linda Damron to call the roll. The results of the roll call vote were:

Present: Chairman Dave Michaelson and Commissioners Dee Spink, Frank Petella, James Joseph, David Creighton, Angelo Christopher, and Ralph Smoot

Absent:

Also Present: Don Bastian, Assistant Community Development Director, and Linda Damron, Secretary.

MINUTES:

Commissioner Spink moved and Commissioner Petella made the second to approve the minutes of the meeting of September 26, 2011. The results of the roll call vote were:

Ayes: 5 Commissioners Christopher, Spink, Petella, Joseph, and Creighton
Nays: 0
Abstain: 2 Commissioner Smoot and Chairman Michaelson
Absent: 0

PUBLIC HEARING:

Commissioner Spink moved and Commissioner Petella made the second to open the Public Hearing. The motion passed by unanimous voice vote.

**Case # 11305 Ray H.C. Fang / Windfall Group – 1175 N. Gary Avenue
Gary Avenue Corridor Review
Minor Amendments to Planned Unit Development Plan
Variations – Sign Code**

Chairman Michaelson swore in the witnesses, Ray Fang, Architect for the Windfall Group, 1175 N. Gary Avenue, Carol Stream, IL. and Eric Cheung, Vice President of Windfall Group, 1175 N. Gary Avenue, Carol Stream, IL. Mr. Ray Fang explained that all the existing landscaping was in poor condition and is proposing to replace it with five oak and maple trees, and bushes planted in curved rings. The Windfall Group believes the new landscaping will improve the entire location. Mr. Fang stated the elevation changes are due to the Windfall Group accommodating Savers thrift store needs, with Savers occupying the north side of the building an additional canopy is needed. The canopy is needed for the donation drop-off area. Savers would like to have the existing siding material above the entryway replaced with dryvit and have a sign with the Savers logo sign. The Windfall Group would also like to build a six foot retaining wall to block the view of Savers compactor.

Mr. Eric Cheung stated that the Windfall Group is proposing to install a sign that is 25 feet in height, and fifteen feet from the property line. The sign will show all the business located in the

center. The new height and location would make the sign visible to traffic traveling south on Gary Avenue.

Chairman Michaelsen asked if anyone from the audience had any questions, there were no questions from the audience.

Chairman Michaelsen asked Mr. Bastian for the staff report.

Assistant Community Development Director Don Bastian, stated as the Plan Commission may recall, the Village Board did approve an ordinance which approved Special Uses for Planned Unit Development, Shopping Center, and Retail and Whole Sales Display Room and Distribution Facility and a Preliminary/Final Planned Unit Development for the property located at 1175 N. Gary Ave, and the Plan Commission approved the Gary Avenue Corridor review. Since the approval the property owner has been working on the construction of the interior and exterior work. The owners of the property have also been looking to secure tenants for this building; they are very close to signing up Savers thrift store to occupy the largest retail space on the north side of the building. To accommodate Savers needs the Windfall Group needs to make some changes to the approved PUD plan and landscaping plan, and they are also requesting sign code variations. For some of you that may not be familiar with Savers, it is a chain thrift store with over 270 stores and 15,000 employees in the United States, Canada and Australia. Local Stores are located in Naperville, Downers Grove and Crystal Lake. Savers will sell donated items as well as new, closeout merchandise and partners with local charities. Savers does donate portion of their sales to local charities.

Mr. Bastian, stated the proposed changes to the PUD plan is to add truck docks at the far northeast corner of the building, a drop off canopy and changes to the landscaping islands in front of the area to help channelize traffic, there will be arrows painted on the pavement and directional signage will be installed. As shown on the PUD plan and as the petitioner mentioned, they are proposing a six-foot tall masonry wall that will extend out 80 feet north of the building, the function of this wall is to both screen all of the service equipment and loading activities and separate the public area from the non-public area. Staff believes the wall will be effective for screening purposes and to keep customers out of the area that is intended for truck traffic. The petitioner has made modifications to the plan with the removal of some parking spaces and one landscape island to help facilitate the movements that an eighteen wheeler would have to make to get into the dock area. With respect to parking, I mentioned that the petitioner will need to eliminate some parking spaces, on the plan that was approved this summer based on the use of space they would need to have 361 for the entire site, and they had 431 spaces. The petitioner is requesting a 35 parking space reduction in the north parking lot area to accommodate the new truck docks and the canopy for the donation drop off area. With the elimination of 35 parking spaces in the north parking lot; the north parking lot would go from 198 spaces to 163 spaces. Based on the 35,000 square foot floor area that Savers would be occupying by code they are required to have 141 parking spaces. They would still have 163 parking spaces after the reduction of 35 parking spaces. Staff recommends approval of the changes to the Planned Unit Development plan.

In regards to the Gary Avenue Corridor review, the petitioner is asking for a trash compactor and garbage area at the far northeast corner of the building, these items would be recessed from the front of the building or behind the masonry wall. One of the primary objectives of the GAC regulations is screening, with these items recessed in or behind the masonry wall and the additional landscaping the screening requirement will be met. Staff recommends approval of the minor changes to the Site Design.

The petitioner is also asking for a change in the architectural design as shown on exhibit H-3, they would like to have the dock doors as far away from Gary Avenue as possible, they will be screening the doors. Staff finds those proposed changes to be consistent with the GAC regulations.

In regards to the landscape plan that was approved this summer it was based on the petitioner keeping the existing landscaping materials. Through the GAC review process we are able to grant points for the existing landscape materials that going to be kept. In September staff noticed that all existing trees and bushes had been removed, at that time staff contacted the property owner and that is when they shared their plans with us for Savers. Staff notified the property owner they would have to bring a new landscaping plan back to the Plan Commission for approval at the same time that they submitted the revised plans for Savers. In the interest of having the new landscape materials installed yet this season before weather conditions would prohibit such installation, the applicant asked staff if they could install the new materials before receiving Plan Commission approval of the revised plan. After having completed an initial review of the revised plan, staff found the plan to be in general conformance with the point value requirements of the GAC regulations. Based on the general conformance of the revised plan, staff advised the applicant that they could proceed with installation of the new plant materials at their own risk; with the understanding that if the plan changed as a result of either continued staff review or changes required by the Plan Commission, they would need to comply with the revisions. As staff we are comfortable with the landscape changes, our only comment is that some of the shrubs that were installed are only moderately salt tolerant, and so if the shrubs die or fail to thrive, staff would suggest that they be replaced with species that are more salt tolerant.

In regards to signage as shown on exhibit D-1, the proposal is to install a Shopping Center Identification Sign which is a type of sign that is allowed for this property in our sign code based on the size of the property and the size of the building. It is a type of sign that is permitted for this property. The Plan Commission does have the responsibility of approving the new ground sign as part of the GAC plans. The sign will be constructed of mostly of stone veneers and limestone, with the top of the sign will feature a modern, curved metal design element. The petitioner is also proposing a Windfall Development identification sign at the south end of the site as shown in exhibit G-1. Both signs are consistent with the GAC regulations.

The petitioner is asking for three sign code variations, the first one is to reduce the setback for this new sign from 40 feet as required to 15 feet. The petitioner explained the factors that would support this request; they want to maximize the visibility of this sign so motorists know who is in this center. The second sign code request is a small increase in the area, to allow the sign to go from 160 square feet to 180 square feet in area. The panel portion of the sign that will have the tenant names in it is 160 square feet; with the WP logo "Windfall Plaza" text at the top of the sign would add about 20 square feet to the total sign area. Staff thinks that this is a minor change and the logo is not commercial advertising, and we are comfortable with the request for the small variance for the area of the sign.

In regards to the setback staff acknowledges the significant investment being made to this property. We also note that in the past this was a single tenant building (formerly Home Base and then Value City) so you pretty much knew who was at this location. The whole idea here is to convert this into a multi unit shopping center and have the individual tenants have the ability to advertise their location, with the need for the individual tenants to advertise their location that would support the need for a highly visible sign. Also as the petitioner discussed, if you are heading southbound on Gary Avenue, there is only one entrance into the shopping center. That is unusual as most shopping centers have multiple ways to get into them; again in this case if

you are a south bound motorist, you have only one change to enter into the shopping center. Staff is comfortable with the variation to reduce the sign setback.

The third variation is to allow a second ground sign to be installed on the property just north of the right-in/right-out entrance at the southern end of the property that would say "Windfall Plaza". Staff initially deliberated as to whether this would even be a sign, or if it could simply be considered a landscape feature. However, per the definitions of the Sign Code, this structure is considered a sign. We note that the sign would be constructed of high quality materials that would tie in with the new design concept for the overall property. Based on the condition that this sign not be allowed to advertise any specific retail tenant, staff can support the variation to allow a second ground sign on the property.

Staff recommends approval of the minor modifications to the Planned Unit Development Plan, the revisions to the Gary Avenue Corridor Plan, and the Sign Code Variations, subject to the conditions listed in Page 9 of the staff report.

Chairman Michaelsen asked if any of his fellow Commissioners had any questions.

Commissioner Joseph wanted to know if semi-trucks and passenger vehicles would be using the same entrance into the shopping center. Commissioner Joseph wanted to know if the new dock area on the north side of center would be only for Savers. Commissioner Joseph wanted to make sure that the height of the new wall would be able to buffer any noise coming from the new dock area.

Mr. Bastian stated that the Engineering Services Department has reviewed the plans, and the curb radius is set up for semi-truck traffic. The petitioner at staff's recommendation did eliminate some landscape islands to improve the maneuvering of semi-truck traffic. Mr. Bastian stated that the new dock area on the north side would be for Savers only and the dock area on the south would be for the small shops and there is also an internal corridor for their use. Mr. Bastian stated that the wall should serve both esthetic purposes and also reduce the noise level purposes.

Commissioner Petella asked with the sign being fifteen feet off the road, is the village planning stopping a right turn out of the center on a red light. Commissioner Petella wanted to make sure that the sign would not be an obstruction to traffic. Commissioner Petella asked the petitioner why they choose trees that would grow to sixty feet tall. Commissioner Petella wanted to remind the petitioner that being on the GAC you can not just remove the landscaping, you first need to talk to someone at the village.

Mr. Bastian wanted to clarify that the sign is not fifteen feet from the road; the sign would be fifteen feet from the property line, and the village is not planning making it a no right turn on a red light. Mr. Bastian stated he did do a site visit to the property and does not believe the sign would be a visibility problem with the sign being set back fifteen feet from the property line.

Mr. Ray Fang stated that they wanted a tree that would have a large trunk and limbs higher up. Mr. Ray Fang did give his apologies to the Plan Commission for removing the existing landscaping.

Commissioner Spink stated with the sign being fifteen feet back from the property line it may hinder the traffic coming from the north due to truck traffic. Commissioner Spink wanted to know what color the building was going to be. Commissioner Spink commended the Windfall Group for coming to Carol Stream and all their hard work on the shopping center.

Mr. Ray Fang stated the building would be painted a beige color.

Don Bastian stated the each tenant would have wall signs, and that would help motorists coming north bound see what types of business are in the center.

Commissioner Smoot wanted to know if all the landscaping on the west side of the property was already planted. Commissioner Smoot wanted to know if the petitioner could look into lighting that would not emit lighting into the atmosphere.

Mr. Cheung stated that the landscaping has been completed. Mr. Cheung stated that the building would have sconce lighting.

Commissioner Christopher did not have any questions for the petitioner.

Commissioner Creighton wanted to know if there was any thought of putting the sign on the other side of the driveway. Commissioner Creighton wanted to know if there would be a curb between the two pillars under the donation drop off canopy.

Mr. Cheung stated that the area on the other side of the driveway is an outlot and when it is developed that business would need a sign. Mr. Cheung stated that they would comply with the village requirements for the area under the canopy.

Chairman Michaelsen stated that with Gary Avenue being a very heavily traveled and salted road, the most important thing is that the plants need to be salt tolerant, and you will need to agree to replace the plant material as needed, but you may be replacing them on an annual basis. Chairman Michaelsen wanted to remind the petitioner that according to landscape drawing they would be planting three foot bushes, if the bushes need to be replaced you have to replace them with three foot bushes. Chairman Michaelsen stated that he likes the way the landscaping looks. Chairman Michaelsen wanted to know if Home Décor was still going to be in the building.

Mr. Cheung stated that Home Décor would still be in the center.

Commissioner Spink moved and Commissioner Petella made the second to recommend approval of the request for the Gary Avenue Corridor review / minor amendments to the Planned Unit Development Plan and recommended approval for the variation to the sign code subject to staff recommendations.

The results of the roll call vote were:

Ayes: 7 Chairman Michaelsen and Commissioners Spink, Smoot, Christopher, Petella,
Joseph and Creighton

Nays: 0

Absent: 0

Chairman Michaelsen reminded the petitioner that the Plan Commission's recommendation would be forwarded to the Village Board at their next meeting on December 19, 2011, at which time the Board would take final action on the matter.

**Case # 11251 Village of Carol Stream – 500 N. Gary Avenue
Text Amendments – Zoning Code**

Chairman Michaelsen swore in the witness, Assistant Community Development Director Don Bastian, 500 N. Gary Avenue, Carol Stream, IL 60188.

Mr. Bastian stated that as you may recall that the a whole host of text amendments were brought to the Plan Commission at the last meeting on September 26th. Twenty of the text amendments were recommended for approval and then went on to be approved by the Village Board. Two of the text amendment where tabled, so staff could do a little more homework and try to address some concerns that were raised by the Plan Commission. Here is some background on what staff was trying to achieve with the text amendments; to provide consistency, improve clarity and enhance the responsiveness of the code to meet customer needs. The proposed text amendment #2 would authorize staff to administratively approve improvements to properties in the Gary and North Avenue Corridors for which there is no significant correlation to the purpose and intent of the corridor regulations, and proposed amendment #21 would authorize staff to administratively approve minor changes to an approved Planned Unit Development Plan. What staff was hoping to accomplish with these text amendments, staff would be authorized to approve building permits for improvements involving exceedingly minor items without needing to require that the property owner obtain approval through the zoning hearing process. Staff heard the concerns on where you draw the line or what is the judgment criteria. Staff wanted to give you some background on cases that we think would fit into this category. The following are examples of minor property improvements or alterations, which exemplify the sorts of requests that could be handled administratively:

Case No. 03357, Premium Products Plus, Inc. – 505 E. North Avenue

The applicant wished to add windows to the front and side of the existing building. North Avenue Corridor Review was required, and was approved unanimously by the Plan Commission.

Case No. 04159, County Farm Plaza – SW Corner County Farm and Army Trail Roads

The owner of the shopping center wished to renovate and rehabilitate the façade of the approximate 110,000 square foot shopping center, which required approval of a minor modification to an approved Planned Unit Development Plan. Approved unanimously by the Plan Commission.

Case No. 07088, Tempo Graphics – 455 E. North Avenue

Tempo Graphics needed to install an overhead door and three rooftop mechanical units on the existing building. The door was to be located over 328 feet away from the North Avenue right-of-way line along the east side of the building, and would be fully screened from view by the building and dense existing landscaping. The rooftop equipment was to be screened in the conventional manner by fluted metal panels painted to match the building. North Avenue Corridor Review was required, and was approved unanimously by the Plan Commission.

Case No. 09300, Mr. Car Wash – 848 Army Trail Road

The business owner wished to construct a small canopy addition to the south side of the existing car wash building to provide a sheltered area for vehicles exiting the car wash. A minor amendment to the approved Planned Unit Development Plan for Heritage Plaza was required, and was approved unanimously by the Plan Commission.

Case No. 10321, Carol's Court – 293-317 S. Schmale Road

The developer had neglected to show on the approved PUD Plan the proposed vacuum stations for the car wash in the Carol's Court commercial development. Because the proposed vacuum stations were to be located within a required corner side yard, Plan Commission approval was required; however, had the vacuum stations been located beyond the setback and properly screened, staff would have been

inclined to view them as a minor modification to the approved PUD Plan, and Plan Commission approval would still have been required. The request was approved unanimously by the Plan Commission.

Staff has had a meeting with an architect about a month ago, the aerial photo that I just distributed shows you Colony Park Apartments located at 530-570 Gundersen Drive. Colony Park Apartments is a 14.44-acre property with 284 apartment units and a 2,558 square foot clubhouse. Colony Park would like to add about a 2,023 square foot addition to the existing clubhouse. The reason I brought this to the Plan Commission is to show an example of what staff would be able to approve without having to have the applicant come before the Plan Commission if the amendment to the text is approved. The current wording of the code requires a minor extension of an existing building would need to come before the Plan Commission for review and approval. Staff feels that this would be a minor project, not that staff does not value the input of the Plan Commission has, but this seems so minor, that having a project like this wait four to six weeks to go through a review process, staff feels that they can't justify that process with something as minor as this. Again this was an example of what staff would like to be able to approve with a building permit only.

Mr. Bastian state that staff did some research on what code requirements other communities had; using the Illinois APA Online forum staff asked the following question: "We are interested in how other communities handle minor changes to approved PUD Plans. Does anyone allow administrative approval of minor changes?" As shown on pages two and three of the staff report some communities said yes we do and some said no we don't. One of the communities that staff focused on was the response from Lombard. Lombard allows staff to approve minor change that do not include deviations for either the underlying zoning district or any adopted development agreement. One example of this would be the Carol's Court project located at 293-317 S. Schmale Road. In that case the zoning code said that the vacuum stations are not allowed to be located in the front yard, so the property owner needed to come before the Plan Commission. What staff likes about how Lombard's code reads is petitioners requesting minor changes to approved planned developments which do not include deviations from either the underlying zoning district or any adopted development agreements shall not be required to submit revised preliminary plan materials, but shall submit revised final plan documents to the Director of Community Development. Staff thought that was a good way to bring clarity or certainty into the code.

The two text amendment that we are working on is to allow staff to approve changes to Gary Avenue / North Avenue Corridor review that are not significant. When making that determination if the text amendment is approved we are going to look at the purpose and intent of the Gary and North Avenue Corridor Regulations. That is what staff is going to use to guide them in making a decision, we have already talked about some of the minor changes that we would consider not significant in the staff report. One of the ones we did not talk about was the case at 505 E. North Avenue in which a single roll-up dock door was added at a location with the roll-up mechanism visible from North Avenue. This work required North Avenue Corridor approval under the current code, and even though the alteration consisted of only a single door, staff would view this sort of work to require Plan Commission approval under the proposed text amendment, as the proposed change was a "significant" one, also a case like #11305 - 1175 N. Gary Ave were the petitioner removed / replaced all the landscaping would, this type of work would also still need to come the Plan Commission for approval. One example of the type of work that would not need to come before the Plan Commission would be if someone wanted to add or replace a roof top unit, staff would like to have the authority to authorize them to do that as long as they screened the equipment. What staff is proposing with respect to the Gary and North Avenue Corridor regulations are the text in blue:

(4) Application of these standards to existing development shall be initiated upon exterior additions to structures or upon significant changes to buildings or property as follows. Whether a change is significant shall be determined by the Community Development Director on the basis of the purpose and intent of the Gary and North Avenue Corridor regulations. as follows

This is where staff will get its guidance; staff will review the purpose and intent of the Gary North Avenue Corridor regulations, if the applicant is trying to do something that goes against that, they will have to bring it to the Plan Commission for approval. Also any new development will have to come before the Plan Commission.

The other text amendment we proposing is #21 what we are proposing are the text in blue:

Minor changes. Minor changes in the location, siting, and height of buildings and structures, and in the location of streets and ways of public access and in the size and location of open space, may be authorized by the ~~Plan Commission~~ Community Development Director as required by engineering or other circumstances not foreseen at the time that the final plan was approved. Whether an alteration constitutes a minor change to an approved planned development plan shall be determined by the Community Development Director in accordance with the following criteria:

1. Does not alter the concept or intent of the planned unit development;
2. Does not violate an adopted development agreement;
3. Does not increase the density of the development;
4. Does not result in any deviations from village standards for the underlying zoning district;
5. Does not result in a significant change in the size or location of any building;
6. Does not change the use of the site;
7. Does not result in a significant increase in building height;
8. Does not reduce open space by more than ten percent from the original planned unit development plan;
9. Does not change the proportion of housing types by more than 15%; or
10. Does not result in a significant change in road standards or locations.

The above list is to address some of the concerns that the Plan Commission had at the September 26th meeting.

Chairman Michaelsen asked if any of his fellow Commissioners had any questions.

Commissioner Creighton stated that he was still uncomfortable with the changes because he does not have the experience to know what is minor and what is not minor.

Mr. Bastian asked if Commissioner Creighton thought that after looking at the example of the Colony Park Apartment with the clubhouse addition would need to be a minor change.

Commissioner Creighton stated that he could not say. Commissioner Creighton referred to tonight's case where it stated a minor change to the PUD and applicant needed to come before the Plan Commission. Commissioner Creighton asked if the signage and the landscaping would be considered a minor change.

Mr. Bastian explained that there were a lot of aspects to the request of Case #11305, 1175 N. Gary Avenue tonight, sign code variation, minor change to the PUD and a complete new landscape plan, with the way the code is currently worded those are minor changes and the Plan Commission would still need see the project at 1175 N. Gary Avenue, because of the sign code variances and the need for GAC review for the new signs and the new landscape plan, this case would have had to come to the Plan Commission regardless, even if the proposed text amendments are approved exactly as they are written. Mr. Bastian stated that the signage and landscaping would not be considered a minor change. Mr. Bastian stated that if all the petitioner wanted to do was move the dumpster that would have been a minor change under the new text amendment.

Commissioner Joseph asked if a minor change would be if someone wanted to paint the façade signage.

Mr. Bastian stated that some requests would be a judgment call and staff will have to look at the purpose and intent of the corridor regulations and on the PUD's we are proposing to follow the ten judgment factors listed in the staff report to help guide us in determining if something is minor or not.

Commissioner Christopher agreed with the proposed text amendments.

Commissioner Petella agreed with the text amendment, but thought that if someone wanted to increase the size of a commercial building it should have to come before the Plan Commission.

Commissioner Spink stated that again it's an opinion and that's a problem it's not clarified. Commissioner Spink stated that an applicant may not understand what is minor and what is not.

After extensive discussion the Plan Commission recommended approval of the text amendment with the following revised wording.

Whether an alteration constitutes a minor change to an approved planned development plan shall be determined by the Community Development Director in accordance with the all following criteria:

Commissioner Christopher moved and Commissioner Petella made the second to recommend approval of the request for Text Amendments #2 and #21 to the Zoning Code subject to revised wording recommended by the Plan Commission.

The results of the roll call vote were:

Ayes: 7 Chairman Michaelsen and Commissioners Spink, Smoot, Christopher, Petella,
Joseph and Creighton
Nays: 0
Absent: 0

Chairman Michaelsen reminded the petitioner that the Plan Commission's recommendation would be forwarded to the Village Board at their next meeting on December 19, 2011, at which time the Board would take final action on the matter.

**Case # 11312 Stantec Architecture / McDonalds Corporation –
1335 County Farm Road
Special Use – Amendment (Dual – Lane Drive – Through Service)
Variation – Off-site Parking**

McDonalds Corporation has asked for a continuance until the January 23, 2012 Plan Commission meeting to respond to the staff recommendation on the site design. Staff recommends that this item be continued until the January 23rd meeting, if the Plan Commission would take that step.

Commissioner Spink moved and Commissioner Petella made the second to continue Case # 11312 until the January 23, 2012, Plan Commission meeting.

The results of the roll call vote were:

Ayes: 7 Chairman Michaelsen and Commissioners Spink, Smoot, Christopher,
Petella, Joseph and Creighton
Nays: 0
Absent: 0

Commissioner Spink moved and Commissioner Petella made the second to close the Public Hearing.

Ayes: 6 Chairman Michaelsen and Commissioners Spink, Christopher, Petella,
Joseph and Creighton
Nays: 1 Commissioner Smoot
Absent: 0

ADJOURNMENT:

At 9:00 p.m. Commissioner Spink moved and Commissioner Petella made the second to adjourn the meeting. The motion passed by unanimous vote.

FOR THE COMBINED BOARD

Recorded and transcribed by,

Linda Damron
Community Development Secretary

Minutes approved by Plan Commission on this January 23, 2012.

Chairman

Village of Carol Stream
Interdepartmental Memo

TO: Joseph E. Breinig, Village Manager

FROM: Robert J. Glees, Community Development Director *RJG*

DATE: December 13, 2011

RE: **Agenda Item for the Village Board Meeting of December 19, 2011**
PC/ZBA Case 11251, Village of Carol Stream
Zoning Code Text Amendments

Recall that at the October 3, 2011, meeting of the Village Board, staff brought forward a series of proposed text amendments to the Zoning Code. The text amendments were intended to update and clarify the Village's standards for residential accessory structures, and also to update other sections of the Zoning Code for the purposes of providing consistency, improving clarity and enhancing the responsiveness of the code to meet customer needs. The Plan Commission recommended approval of 20 of the 22 text amendments proposed by staff, and these were brought to the Village Board and approved. Two of the 22 proposed text amendments were tabled to the December 12, 2011, Plan Commission meeting for further discussion.

The two proposed text amendments which required further discussion by the Plan Commission had to do with giving staff the authority to approve building permits for business improvements involving exceedingly minor items without needing to require that the business owner obtain approval through the zoning hearing process. One of the amendments authorizes staff to administratively approve minor improvements to properties in the Gary and North Avenue Corridors for which there is no significant correlation to the purpose and intent of the corridor regulations, while the other authorizes staff to administratively approve minor changes to an approved Planned Unit Development Plan, subject to specific criteria.

The staff report presenting the draft Zoning Code Text Amendments was transmitted to the Village Board with the Plan Commission/Zoning Board of Appeals (PC/ZBA) packet on December 9, 2011. At their December 12, 2011, meeting, the PC/ZBA recommended approval of the two Zoning Code Text Amendments recommended by staff by a vote of 7-0.

If the Village Board concurs with the PC/ZBA recommendation regarding the Zoning Code Text Amendments, they should approve the Zoning Code Text Amendments and adopt the necessary Ordinance.

RJG:bg

t:\planning\plan commission\staff reports\2011 staff reports\11251d.textamend.zoning code misc revisions.vbmemo.doc

Village of Carol Stream
Interdepartmental Memo

TO: Joseph E. Breinig, Village Manager

FROM: Donald T. Bastian, Assistant Community Development Director *JB*

THROUGH: Robert J. Glees, Community Development Director *RJG*

DATE: December 15, 2011

RE: **Agenda Item for the Village Board Meeting of December 19, 2011**
PC/ZBA Case 11305, Direct Import Home Décor/Windfall Group – 1175 N. Gary Avenue
Minor Modifications to an Approved Planned Unit Development Plan, Gary Avenue Corridor Review and Sign Code Variations

This summer, the Village Board adopted Ordinance 2011-07-20, which approved Special Uses for *Planned Unit Development, Shopping Center, and Retail and Wholesale Sales and Display Room and Distribution Facility*, and a Preliminary/Final Planned Unit Development Plan for the property at 1175 N. Gary Avenue. As part of the same application, the Plan Commission also approved the Gary Avenue Corridor (GAC) plans and Sign Code Variations to allow two, 10-foot tall ground directory signs. Since the granting of these approvals, the property owner has been working on building and site improvements, and has also been working to secure tenants for the building.

At this time, *Savers* thrift stores is close to signing a lease to occupy the northern 35,000 s.f. space in the 105,000 s.f. building. *Savers* is a thrift store chain with over 270 stores in the U.S., Canada and Australia, with local stores in Naperville, Downers Grove and Crystal Lake. *Savers*, which sells both donated items and new, "closeout" merchandise, partners with local charities and donates a portion of their sales to the charities. To accommodate *Savers* operational needs, the property owner is proposing minor modifications to the approved PUD Plan, including a customer donation canopy on the north side of the building and truck docks near the northeast corner of the building. The owner is also seeking Sign Code Variations to allow a Shopping Center Identification sign to be set back 15 feet from the front property line as opposed to 40 feet as required, for the sign to measure 180 s.f. in area as opposed to 160 s.f. as required, and to install a development identification sign (with no commercial advertising) at the south end of the property. Finally, the owner also requested approval of revised GAC plans to accommodate changes to the approved architectural and landscape plans.

The staff report presenting the requests, with supporting documentation, was transmitted to the Village Board with the Plan Commission/Zoning Board of Appeals (PC/ZBA) packet on December 9, 2011. At their December 12, 2011, meeting, by a vote of 7-0, the PC/ZBA approved the minor modifications to the PUD Plan and the changes to the GAC plans. Also by a 7-0 vote, the PC/ZBA approved the three Sign Code Variations.

The Plan Commission has the authority to approve or deny Sign Code Variation requests. However, the Sign Code grants the Village Board the opportunity to affirm or reverse the decision of the Plan Commission within 21 days of the date that the request first appears before the Village Board. If the Village Board takes action on the Sign Code Variation requests, their decision is final. If the Board takes no action within the 21-day period set forth in the Sign Code, the decision of the Plan Commission to approve the variations is final. The PC/ZBA action regarding the minor modifications to the PUD Plan and revisions to the approved GAC plans serves as the final decision.

DTB:db

c: Eddie Ni, Windfall Group (via e-mail)
Eric Cheung, Windfall Group (via e-mail)
Ray Fang, Architect (via e-mail)

T:\Planning\Plan Commission\Staff Reports\2011 Staff Reports\11305a.DIH.pudgacvar.vbmemo1.doc

Village of Carol Stream Interdepartmental Memo

DATE: December 12, 2011

TO: Mayor Saverino Sr. & Village Board of Trustees
Joseph E. Breinig, Village Manager

FROM: Christopher M. Oakley, Assistant to the Village Manager

RE: Contract Amendment – WRC Sludge Aeration Blower Replacement Project

PROJECT BACKGROUND:

In 2008, the Village was awarded a \$173,000 federal stimulus grant to help fund identified energy efficiency projects as part of the American Recovery & Reinvestment Act (ARRA). The Village submitted a project application to the U.S. Dept. of Energy (US-DOE) seeking approval to utilize funds to conduct a Phase I energy-efficient upgrade of sanitary sludge aeration process. In September 2009, the US-DOE approved the Village's request and executed a grant agreement that included a formal notice to proceed at the WRC.

In December of 2009, the Village conducted an initial pre-project meeting with Baxter & Woodman (B&W) Consulting Engineers, the engineer of record for Phase II (1993) & III (2000) Expansion of the WRC, to solicit their credentials and expertise to design and manage this type of energy efficiency project. B&W presented the Village documentation, client contact information and a detailed engineering case study to establish them as a reputable firm to both design and manage this US-DOE-approved project. In January 2010, a preliminary project meeting with B&W was held at which time the Village requested the firm to develop a Design/Build Contract for the Phase I Sludge Aeration Energy Efficiency project for the Village Board's consideration. During that same meeting, the issue of full project cost funding was discussed and the Village asked B&W to submit an application to the Illinois Department of Economic Opportunity requesting supplemental grant funding to help close the project's funding gap estimated at \$141,400. IL-DCEO approved a preliminary Public Sector Energy Efficiency Grant for \$84,900, calculated at 12¢/kWh reduced estimated at 707,500 kWh. This supplemental funding successfully reduced the project funding gap to \$56,500.

On May 17, 2010, the Village Board approved a Design/Build Contract with Baxter & Woodman for the lump sum amount of \$293,600 to provide both engineer design and construction management of the WRC Sludge Aeration Energy Retrofit Project. Shortly thereafter, an estimated project timeline was submitted for review and a pre-construction meeting and a project site visit was conducted at the WRC.

PROJECT COST OVERRUNS:

Project engineering design work began in June 2010 and continued through the fall at which time OMI/CH2MHILL and the Village approved the final shop drawings for the installation of a turbo blower.

An order was placed for the blower unit in the fall of 2010 and was delivered in late Feb. 2011 with installation work beginning shortly thereafter. A series of unforeseen project delays arose that included the need for additional electrical improvements resulting from inadequate electrical capacity, the removal of the existing concrete pad and installation of a custom pad for the new unit, as well as the relocation of existing blower valves. This project work required to 200 additional hours of contractor labor that increased the project's cost by \$33,599. The contractor also requested the approval of \$8,256.20 in additional project costs for the purchase of a harmonic filter for the new blower unit. Shortly after the design/build contract was executed and before the new turbo blower unit was ordered, the unit's manufacturer HSI made the harmonic filter standard with the blower's purchase and no longer optional. The installation of a harmonic filter on the turbo blower unit was deemed necessary to improve the electrical efficiency of the new unit and its impact on electrical loadings of the other WRC buildings. The amount of the supplemental project costs was \$41,855.20.

The project was completed this past summer and the post project monitoring of the electrical loadings began in earnest to determine the improved energy efficiency of this improvement which was required by both the Department of Energy and IL-DCEO. The post-project power monitoring of the sludge aeration retrofit project recorded substantial energy improvements that reduced total energy use by 1,473,534 kWh, a 108% increase from the initial estimates detailed in the original pre-project grant application. IL-DECO approved final grant funding for the project totaling \$176,824, increasing the supplemental funding costs by \$91,924 and completely closing the project funding gap. The total project cost including the supplemental work totals \$327,199 while the governments grants approved for the project totaled \$329,024. **To date, the Village has not yet received the DCEO grant award and recommends approval of this contract amendment contingent on the receipt of those proceeds.**

Attached is required documentation from the contractor documenting the cost for supplemental work that includes contractor invoices, a sworn contractor statement, a final waiver of liens as well as a contract amendment seeking formal approval of the documented \$41,855.20 project increase payable to Baxter & Woodman. Please include this request on the upcoming December 19th agenda for the Village Board's consideration.

- attachments (5):** B&W Memo
Sworn Contractor Statement
Final Waiver of Liens
Contract Amendment
IL-DCEO Final Approved Grant Request

MEMORANDUM



Mokena Office

8840 West 192nd Street
Mokena, IL 60448
Phone: 708.478.2090
Fax: 708.478.8710

Corporate Website: www.baxterwoodman.com e-mail: info@baxterwoodman.com

DATE: December 7, 2011

TO: Joe Breinig, Village Manager, Village of Carol Stream

FROM: Derek Wold

SUBJECT: 100205.40 – Aeration System Improvements Contract Amendments

Aeration System Improvements project at the Village's Water Reclamation Center are now complete. This letter outlines Amendment No. 1 to the Design/Build Agreement for costs that exceed the original contract value that include unanticipated construction and engineering costs and the installation of a harmonic filter for the new turbo blower. The scope of services for the amendment is described below.

Additional Cost Items

The original contract amount of \$293,600 was based on the engineer's opinion of probable cost (OPC) from the grant application and is listed in Table 1. This OPC was developed during the preparation of the grant application, prior to completion of any engineering design work.

Table 1. Engineer's Opinion of Probable Cost versus Actual Costs.

Original Contract	OPC	Actual
HSI Blower	\$ 172,500	\$ 168,045.00
Instrumentation & Controls	\$ 25,000	\$ 26,235.89
Contractor (includes OH&P, bond, insurance)	\$ 32,600	\$ 68,888.00
Engineering, Legal, & Admin., Contingency	\$ 63,500	\$ 64,030.11
Total	\$ 293,600	\$ 327,199.00

The largest deviation from the original contract was for contractor expenses. When the initial OPC was compiled, the contractor expenses were projected based on a percent of the total construction cost. The original contract did not contemplate wiring/electrical upgrades to the blower building that during installation became necessary for the proper functioning of the new blower. As we proceeded into detailed design, it became evident that a more detailed scope of electrical improvements was required. Other unanticipated project costs included the removal of the existing concrete pad and relocation of the existing valves to accommodate the new blower. These additional construction costs are documented in the attached invoices, sworn statement, and

waiver of lien. In the OPC, the contractor costs were budgeted at approximately 11% of the total project cost. The additional contractor costs for concrete, electrical work, as well as valve relocation required additional materials and approximately 220 additional contractor hours beyond the original OPC estimates.

Project engineering costs budgeted in the original OPC included design of the aeration system, preparation of the aeration system final report, construction administration, and grant preparation. Additional project engineering was necessary for the detailed design to accommodate the construction items noted above, as well as resolving problems with the existing electrical on the aeration tanks to accommodate the Dissolved Oxygen (DO) probes. Additional engineering was also required to monitor the blower power usage after installation to justify increased grant funding, analyzing the data, and coordinating with DCEO to finalize the revised application.

Harmonic Filter

Baxter & Woodman designed one of the first HSI installations in the State of Illinois at the City of Belvidere. The blowers at the City of Belvidere are 200-hp machines and were not installed with harmonic filters. Between project completion in Belvidere and project construction at the Village of Carol Stream, HSI standardized harmonic filters on all their blower packages. Harmonic filters are not always required on turbo blowers; therefore our design did not initially include a harmonic filter.

Harmonic filters are placed before the variable frequency drive (VFD) to reduce the transmission of electrical noise into a building's electrical system. This noise is a natural phenomenon caused by harmonic distortion of the electrical signal. Larger motors or VFDs cause larger total harmonic distortion (THD). Harmonic filters do not provide cost-savings or financial benefits, but they improve the quality of the electrical system locally in the rest of the WRC.

To assess the potential impacts on other buildings of operating the blower without the harmonic filter, all of the electrical loads in the building must be analyzed considering how many motors are on VFD drives and the size and impedance of the power company's transformer. However, the definite impact is that the distortion causes low power factors, effectively translating to wasted energy.

After installing the blower at Carol Stream, monitoring was performed to determine the quality of the electrical system with the blower. The harmonics at the blower building were considerably stronger than Baxter & Woodman has seen at other facilities. That being said, installation of the harmonic filter is recommended at a cost of \$8,256.20.

Engineers' Fee

A breakdown of the contract amendments is shown in Table 2, below.

Table 2. Amendment No. 1 Summary

Contract Amendments	
Contractor Labor	\$ 33,599.00
Harmonic Filter	\$ 8,256.20
Total Amendment	\$ 41,855.20

If enclosures are not as noted, please notify us at once.

The fee for the contract amendments described above is \$41,855.20. If this agreement meets with your approval, please have both copies of the attached Engineering Service Agreement Amendments executed. Return one copy to our office and retain one copy for your files.

We look forward to being of continued assistance to the Village. Please call if you have any questions.

If enclosures are not as noted, please notify us at once.

Filepath: \\corp.baxwood.com\Projects\Mokena\CRSTV\100205-aeration ene\Amendment Cover Letter_Memo.doc

FINAL WAIVER OF LIEN

STATE OF ILLINOIS)
 COUNTY OF LAKE)

TO WHOM IT MAY CONCERN:

WHEREAS the undersigned has been employed by Concord Construction Services, Inc.
 to furnish General Contract
 for the premises known as Carol Stream WRF Blower Replacement
 of which Village of Carol Stream is the Owner.

THE undersigned, for and in consideration of \$ Eighteen Thousand Four Hundred Forty-Two and 10/100
\$ 18,442.10 Dollars, and other good and valuable considerations, the receipt whereof is hereby acknowledged,
 does hereby waive and release any and all lien, or claim of lien, or right to lien, with respect to and on the above described premises, and the improvements thereon,
 and on the material, fixtures, apparatus or machinery furnished, and on the monies, funds or other consideration due or to become due from the Owner, on account
 of labor, services, material, fixtures, apparatus or machinery furnished, to this date by or on behalf of the undersigned, for the above-described premises.

The undersigned does further release any and all claims of any nature whatsoever, against Baxter & Woodman, Inc., or its surety, relating to or arising out of the
 performance of the Work, including claims under 40 U.S.C. sections 270a-270d ("the Miller Act"), or any state statute serving a substantially similar purpose.

Given under my hand and seal
 this 22nd day of July, 2011.

Signature and Seal: *Michael L. Henderson*
 Michael L. Henderson, President

Company Name & Address: Concord Construction Services, Inc. 570 Oakwood Rd., Lake Zurich, IL 60047

NOTE: All waivers must be for the full amount paid. If waiver is for a corporation, corporate name should be used, corporate seal affixed and title of officer signing
 waiver should be set forth; if waiver is for a partnership, the partnership name should be used, partner should sign and designate himself as partner.

CONTRACTOR'S AFFIDAVIT

STATE OF ILLINOIS)
 COUNTY OF LAKE)

TO WHOM IT MAY CONCERN:

THE undersigned, being duly sworn, deposes and says that he/she is Michael L. Henderson, President
 of the Concord Construction Services, Inc.
 who is the contractor for the General Contract
 work on the building located at Carol Stream WRF Blower Replacement
 owned by Village of Carol Stream

That the total amount of the contract including extras is \$ 68,888.00
 on which he/she has received payment of \$ 50,445.90 prior to this payment. That all waivers are true, correct and genuine and
 delivered unconditionally and that there is no claim either legal or equitable to defeat the validity of said waivers. That the following are the names of all parties who
 have furnished material or labor, or both, for said work and all parties having contracts for specific portions of said work or for material entering into the construction
 thereof and the amount due or to become due to each, and that the items mentioned include all labor and material required to complete said work according to plans
 and specifications:

NAMES	WHAT FOR	CONTRACT PRICE	AMOUNT PAID	THIS PAYMENT	BALANCE TO BECOME DUE
Concord Construction Services, Inc.	General Contract	\$68,888.00	\$50,445.90	\$18,442.10	\$0.00
TOTAL LABOR AND MATERIAL TO COMPLETE		\$68,888.00	\$50,445.90	\$18,442.10	\$0.00

That there are no other contracts for said work outstanding, and that there is nothing due or to become due to any person for material, labor or other
 work of any kind done or to be done upon or in connection with said work other than above stated.

Signed this 22nd day of July, 2011.

Signature: *Michael L. Henderson*
 Michael L. Henderson, President

Subscribed and sworn to before me this 22nd day of July, 2011.

Signature: *Scott M. Hendon*
 Notary Signature & Seal



FINAL WAIVER OF LIEN

STATE OF ILLINOIS
COUNTY OF COOK

GT#
ESCROW#

TO WHOM IT MAY CONCERN:

WHEREAS the undersigned has been employed by Concord Construction Services, Inc. to furnish mechanical work for the premises known as Carol Stream WRF Blower Replacement, of which Village of Carol Stream is the owner.

The undersigned, for and in consideration of Twenty Seven Thousand Fifty One and 00/100 (\$27,051.00) Dollars, and other good and valuable consideration, the receipt whereof is hereby acknowledged, do(es) hereby waive and release any and all lien or claim of, or right to, lien, under the statutes of the State of Illinois, relating to mechanics' liens, with respect to and on said above-described premises, and the improvements thereon, and on the material, fixtures, apparatus or machinery furnished, and on the moneys, funds or other considerations due or to become due from the owner, on account of labor, services, material, fixtures, apparatus or machinery heretofore furnished, or which may be furnished at any time hereafter, by the undersigned for the above-described premises.

DATE: 7/22/11 COMPANY NAME: Dahme Mechanical Industries, Inc.
610 S. Arthur Avenue, Arlington Heights, IL 60005

SIGNATURE AND SEAL: *Robert D. LaMantia*
Robert D. LaMantia, President

CONTRACTOR'S AFFIDAVIT

STATE OF ILLINOIS
COUNTY OF COOK

TO WHOM IT MAY CONCERN:

THE undersigned, Robert D. LaMantia, being duly sworn, deposes and says that he is President of Dahme Mechanical Industries, Inc. who is the contractor for the mechanical work for the building located Carol Stream WRF Blower Replacement, owned by Village of Carol Stream.

That the total amount of the contract including extras is \$27,051.00 on which he has received payment of \$0.00 prior to this payment. That all waivers are true, correct and genuine and delivered unconditionally and that there is no claim either legal or equitable to defeat the validity of said waivers. That the following are the names of all parties who have furnished material or labor, or both for said work and all parties having contracts or subcontracts for specific portions of said work or for material entering into the construction thereof and the amount due or to become due to each, and that the items mentioned include all labor and material required to complete said work according to plans and specifications:

NAME	WHAT FOR	CONTRACT PRICE INCLUDING EXTRAS*	AMOUNT PAID	THIS PAYMENT	BALANCE DUE
Dahme Mechanical	Mechanical Work	27,051.00	0.00	27,051.00	0.00
All material taken from fully paid stock & delivered to jobsite in company vehicles.					
All labor paid in full. Balance due for labor is zero.					
	TOTALS	27,051.00	0.00	27,051.00	0.00

That there are no other contracts for said work outstanding, and that there is nothing due or to become due to any person for material, labor or other work of any kind done or to be done upon or in connection with said work other than above stated.

DATE: 7/22/11 SIGNATURE: *Robert D. LaMantia*
Robert D. LaMantia, President
Subscribed and sworn to before me this 22nd day of July, 2011.



Lorraine Kull
Lorraine Kull, Notary Public

FINAL WAIVER OF LIEN

STATE OF INDIANA)
 COUNTY OF LAKE)

TO WHOM IT MAY CONCERN:

WHEREAS the undersigned has been employed by Concord Construction Services, Inc.
 to furnish Painting
 for the premises known as Carol Stream WRF Blower Replacement
 of which Village of Carol Stream is the Owner.

THE undersigned, for and in consideration of \$ Three Thousand and 00/100 -----
 \$ 3,000.00 Dollars, and other good and valuable considerations, the receipt whereof is hereby acknowledged,

does hereby waive and release any and all lien, or claim of lien, or right to lien, with respect to and on the above described premises, and the improvements thereon, and on the material, fixtures, apparatus or machinery furnished, and on the monies, funds or other consideration due or to become due from the Owner, on account of labor, services, material, fixtures, apparatus or machinery furnished, to this date by or on behalf of the undersigned, for the above-described premises.

The undersigned does further release any and all claims of any nature whatsoever, against Concord Construction Services, Inc., or its surety, relating to or arising out of the performance of the Work, including claims under 40 U.S.C. sections 270a-270d ("the Miller Act"), or any state statute serving a substantially similar purpose.

Given under my hand and seal
 this 25th day of July, 2011.

Signature and Seal: *Paul Liller*

Company Name & Address: P&S Painting, Inc. P.O. Box 189, Dyer, IN 46311

NOTE: All waivers must be for the full amount paid. If waiver is for a corporation, corporate name should be used, corporate seal affixed and title of officer signing waiver should be set forth; if waiver is for a partnership, the partnership name should be used, partner should sign and designate himself as partner.

CONTRACTOR'S AFFIDAVIT

STATE OF INDIANA)
 COUNTY OF LAKE)

TO WHOM IT MAY CONCERN:

THE undersigned, being duly sworn, deposes and says that he/she is _____
 of the P&S Painting, Inc.
 who is the contractor for the Painting
 work on the building located at Carol Stream WRF Blower Replacement
 owned by Village of Carol Stream

That the total amount of the contract including extras is \$ 3,000.00
 on which he/she has received payment of \$ 0.00 prior to this payment. That all waivers are true, correct and genuine and delivered unconditionally and that there is no claim either legal or equitable to defeat the validity of said waivers. That the following are the names of all parties who have furnished material or labor, or both, for said work and all parties having contracts for specific portions of said work or for material entering into the construction thereof and the amount due or to become due to each, and that the items mentioned include all labor and material required to complete said work according to plans and specifications:

NAMES	WHAT FOR	CONTRACT PRICE	AMOUNT PAID	THIS PAYMENT	BALANCE TO BECOME DUE
P&S Painting, Inc.	Painting	\$3,000.00	\$0.00	\$3,000.00	\$0.00
TOTAL LABOR AND MATERIAL TO COMPLETE		\$3,000.00	\$0.00	\$3,000.00	\$0.00

That there are no other contracts for said work outstanding, and that there is nothing due or to become due to any person for material, labor or other work of any kind done or to be done upon or in connection with said work other than above stated.

Signed this 25th day of July, 2011.

Signature: *Paul Liller*

Subscribed and sworn to before me this 25th day of July, 2011.

Signature: *Kathleen M. Wachel*
 Notary Signature & Seal

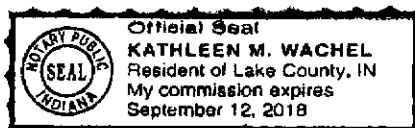

FINAL WAIVER OF LIEN

STATE OF ILLINOIS)
 COUNTY OF DUPAGE)

TO WHOM IT MAY CONCERN:

WHEREAS the undersigned has been employed by Concord Construction Services, Inc.
 to furnish Electrical
 for the premises known as Carol Stream WRF Blower Replacement
 of which Village of Carol Stream is the Owner.

THE undersigned, for and in consideration of \$ Six Thousand Two Hundred Ten and 00/100
\$ 6,210.00 Dollars, and other good and valuable considerations, the receipt whereof is hereby acknowledged,
 does hereby waive and release any and all lien, or claim of lien, or right to lien, with respect to and on the above described premises, and the improvements thereon,
 and on the material, fixtures, apparatus or machinery furnished, and on the monies, funds or other consideration due or to become due from the Owner, on account of
 labor, services, material, fixtures, apparatus or machinery furnished, to this date by or on behalf of the undersigned, for the above-described premises.

The undersigned does further release any and all claims of any nature whatsoever, against Concord Construction Services, Inc., or its surety, relating to or arising
 out of the performance of the Work, including claims under 40 U.S.C. sections 270a-270d ("The Miller Act"), or any state statute serving a substantially similar purpose.

Given under my hand and seal
 this 25 day of July, 2011.

Signature and Seal: [Signature]

Company Name & Address: Stelmach Electric, Inc. 0N510 Herrick Dr., Wheaton, IL 60187

NOTE: All waivers must be for the full amount paid. If waiver is for a corporation, corporate name should be used, corporate seal affixed and title of officer signing
 waiver should be set forth; if waiver is for a partnership, the partnership name should be used, partner should sign and designate himself as partner.

CONTRACTOR'S AFFIDAVIT

STATE OF ILLINOIS)
 COUNTY OF DUPAGE)

TO WHOM IT MAY CONCERN:

THE undersigned, being duly sworn, deposes and says that he/she is _____
 of the Stelmach Electric, Inc.
 who is the contractor for the Electrical
 work on the building located at Carol Stream WRF Blower Replacement
 owned by Village of Carol Stream

That the total amount of the contract including extras is \$ 26,210.00
 on which he/she has received payment of \$ 20,000.00 prior to this payment. That all waivers are true, correct and genuine and
 delivered unconditionally and that there is no claim either legal or equitable to defeat the validity of said waivers. That the following are the names of all parties who
 have furnished material or labor, or both, for said work and all parties having contracts for specific portions of said work or for material entering into the construction
 thereof and the amount due or to become due to each, and that the items mentioned include all labor and material required to complete said work according to plans
 and specifications.

NAMES	WHAT FOR	CONTRACT PRICE	AMOUNT PAID	THIS PAYMENT	BALANCE TO BECOME DUE
Stelmach Electric, Inc.	Electrical	\$26,210.00	\$20,000.00	\$6,210.00	\$0.00
TOTAL LABOR AND MATERIAL TO COMPLETE		\$26,210.00	\$20,000.00	\$6,210.00	\$0.00

That there are no other contracts for said work outstanding, and that there is nothing due or to become due to any person for material, labor or other
 work of any kind done or to be done upon or in connection with said work other than above stated.

Signed this 25 day of July, 2011.

Signature: [Signature]

Subscribed and sworn to before me this 25th day of July, 2011.

Signature: [Signature]
 Notary Signature & Seal



01/30/03

VILLAGE OF CAROL STREAM, ILLINOIS
WATER RECLAMATION CENTER AERATION SYSTEM
ENERGY EFFICIENCY IMPROVEMENTS – PHASE I

***DESIGN/BUILD SERVICES AGREEMENT
AMENDMENT NO.1***

THIS AGREEMENT AMENDMENT is made this ___ day of _____, 2011, by and between the Village of Carol Stream, Illinois, hereinafter referred to as the VILLAGE, and Baxter & Woodman, Inc., Consulting Engineers, hereinafter referred to as the ENGINEERS for the purpose of amending the Design/Build Services Agreement between these parties dated May 17, 2010 hereinafter referred to as the AGREEMENT to include additional costs related to the design and construction of the new blower. This also includes costs related to obtaining data, analyzing power usage and coordinating with the Department of Commerce and Economic Opportunity (DCEO) on increasing the Village's grant funding by approximately \$91,000.

WITNESSETH that in consideration of the covenants herein, these parties agree as follows:

SECTION 2.1 of the AGREEMENT is hereby amended to:

“The ENGINEERS’ fee for the additional design and construction related services shall be a lump sum of \$41,855.20”.

All other provisions of the AGREEMENT shall remain in full force and effect.

IN WITNESS WHEREOF, the parties hereto have caused the execution of this Agreement by their duly authorized officers as of the day and year first above written.

01/30/03

BAXTER & WOODMAN, INC.

VILLAGE OF CAROL STREAM, ILLINOIS

By _____
Vice President

By _____
Mayor

Date of Signature

Date of Signature

(SEAL)

(SEAL)

ATTEST:

ATTEST:

Deputy Secretary

Clerk

Attachment

I:\B&WFORMS\Engr Svc Agreements\ESA AMENDMENT.doc



Illinois Department of Commerce & Economic Opportunity

Pat Quinn, Governor • Warren Ribley, Director

September 06, 2011

Mr. Joseph Breinig, Village manager
Carol Stream Village of
500 N. Gary Ave.
Carol Stream, IL 60188-1899

Re: 4028 Carol Stream Village of

Dear Mr. Breinig,

The Department is in receipt of your Public Sector Energy Efficiency Pre-approval Application install a new aeration blower at the Water Reclamation Center. Your **Application #4028** has been reviewed and was found to meet all the necessary requirements to proceed with the proposed project. Please refer to **Application #4028** for all correspondence regarding this project.

Enclosed you will find the grant application for your project. As per program guidelines, projects over \$50,000 require a grant agreement with the Department. Please complete sections 1, 2, 6, and 9 and verify the information throughout the document. Grant applications must be received within 30 days of the date on this letter and either mailed to Tom Coe, IL DCEO Energy Office, 500 E. Monroe, Springfield, IL 62701. Scanned grant agreements can be submitted electronically to illinois.energy@illinois.gov or tom.coe@illinois.gov.

If you have any questions regarding this application process, please contact Tom Coe, Public Sector Energy Efficiency Program (PSEE), (217)785-2433 or tom.coe@illinois.gov.

Sincerely,

Tom Coe
PSEE Program

www.ildceo.net

500 East Monroe
Springfield, Illinois 62701-1643
217/782-7500 • TDD: 800/785-6055

James R. Thompson Center
100 West Randolph Street, Suite 3-400
Chicago, Illinois 60601-3219
312/814-7179 • TDD: 800/785-6055

2309 West Main, Suite 118
Marion, Illinois 62959-1180
618/997-4394 • TDD: 800/785-6055

Printed on Recycled and Recyclable Paper

SECTION 3: PROPOSAL INFORMATION

3.1	Submittal Date:	02/28/2010	
3.2	Project Title:	Public Sector Energy Efficiency Program	
3.3	Brief Project Description: <i>(Complete attached Scope of Work) (550 Character maximum)</i>	Aeration Blower	
3.4	Project Location:	Street Address: City:	245 N. KUHN RD CAROL STREAM County: DuPage
3.5	Areas Served:	N/A	
3.6	Project Contact:	Name: Title: Address: Phone: Fax: E-Mail:	Joseph Breinig Village Manager 500 N. Gary Ave., Carol Stream, IL. 60188-1899 (630)871-6250 (630)665-1064 jbreinig@carolstream.org
3.7	Project Period:	Start Date: 06/01/11	End Date: 05/12/12
3.8	Project Costs: <i>(Complete attached Budget)</i>	Funding provided by the applicant: Secured funding from other sources: Funding requested from DCEO:	\$116,776.00 \$0.00 \$176,824.00
		Total Project Cost	\$293,600.00

SECTION 4: SCOPE OF WORK

City of Chicago Street Lights

Description of project: This project meets the objectives of the Public Sector Energy Efficiency (PSEE) Program by implementing cost-effective energy efficiency measures and creating energy savings. Implementing such measures will also enhance economic development in the State of Illinois through job creation and business development.

Grantee will complete the following tasks:

DESCRIPTION OF TASKS	ESTIMATED COMPLETION DATE
Task 1. See attachment A	5/31/2012
Task 2.	
Task 3.	
Task 4.	
Task 5.	
Task 6.	
Task 7.	
Task 8.	

SECTION 5: PERFORMANCE MEASURES

Performance Measure	Target
Energy Savings	1,473,534.00 kWh's

SECTION 6: PROJECTED EMPLOYMENT IMPACT

6.1	Number of permanent full-time individuals currently employed by applicant:	143
6.2	Number of permanent part-time individuals currently employed by applicant:	10
6.3	Number of permanent full-time jobs that would be created by applicant as a direct result of receiving the grant award:	0
6.4	Number of permanent part-time jobs that would be created by applicant as a direct result of	0

	receiving the grant award:	
6.5	Number of permanent full-time jobs that would be retained by applicant as a direct result of receiving the grant award:	0
6.6	Number of permanent part-time jobs that would be retained by applicant as a direct result of receiving the grant award:	0
6.7	Describe any other projected employment impact as a result of receiving the grant award: None	

SECTION 7: BUDGET

Line Item or Cost Category Description	Requested Grant Budget Amount	Proposed Match Budget Amount
PSEE Project	\$176,824.00	
Total Cost	\$176,824.00	\$0.00

SECTION 8: PROGRAM SPECIFIC INFORMATION

1.1 Purpose. The Illinois Department of Commerce and Economic Opportunity (the "Department" or "DCEO") administers the **Illinois Energy Now ("IEN")** portfolio of programs to implement cost-effective energy efficiency measures that help meet annual energy savings targets. Implementing such measures will also enhance economic development in the state of Illinois through job creation and business development. The Public Sector Energy Efficiency Program ("Public Sector Program") will, to the extent funds are available, provide incentives for projects that increase the energy efficiency of local governments, municipal corporations, public school districts, community college districts, public universities, and state/federal facilities located in the service territories of Ameren Illinois ("Ameren"), Commonwealth Edison ("ComEd"), Nicor Gas ("Nicor"), Peoples Gas ("Peoples"), and/or North Shore Gas ("North Shore").

The Public Sector Program will offer both "Standard" and "Custom" incentives. The Standard program provides incentives for the specific electric and natural gas measures listed in Appendix B. The measures are listed under the following categories:

- Lighting
- Heating, Ventilation, Air Conditioning (HVAC) and Water Heaters
- Motors
- Kitchen

The Custom program provides incentives for other electric and natural gas measures as described in Appendix C, and not listed under the Standard program.

Village of Carol Stream

Interdepartmental Memo

TO: Joe Breinig, Village Manager

FROM: Philip J. Modaff, Director of Public Works 

DATE: December 16, 2011

RE: Recommendation to Award a Contract to Dahme Mechanical, Inc. for Construction of a Sodium Hypochlorite Delivery System at the WRC

In May 2011 staff began work with consulting engineering firm Baxter & Woodman for the design of the replacement of the sodium hypochlorite (chlorine) delivery system at the Water Reclamation Center (WRC). The delivery system is part of the final treatment process, introducing chlorine to the process just prior to sand filtration and subsequent discharge to the creek. The existing system has suffered leaks in the underground piping on two occasions over the past three years. This replacement project was intended to replace the existing piping and upgrade the overall delivery system to make it more reliable and less prone to leaks.

Following completion of design the project was publicly bid and three firms submitted bids. Unfortunately, there were several technicalities in the bids and on November 21, 2011, the Village Board approved staff's recommendation to reject all bids and re-bid the project.

The project was re-bid and four bids were submitted for the bid opening on December 15. Attached is a bid tabulation and recommendation of award from Baxter & Woodman. Below is a summary of the bids received:

<u>Bidder</u>	<u>Amount¹</u>
Dahme Mechanical	\$154,444 ²
Independent Mechanical	\$157,500
Marc Kresmery Constr.	\$177,474
Kovicic Construction	Not read ³

Staff recommends that the Village Board approve a Motion Awarding a contract to Dahme Mechanical, Inc., in the amount of \$154,444.00 for construction of a sodium hypochlorite delivery system at the WRC.

Attachment

¹ The engineer's estimate of probable cost for this project was \$190,000.

² This bid is \$4,444 less than the lowest bid submitted in the first bid process (also submitted by Dahme)

³ Kovicic failed to submit several required forms and therefore their bid was deemed unresponsive



December 16, 2011

Mayor and Board of Trustees
Village of Carol Stream
500 North Gary Avenue
Carol Stream, Illinois 60188

Attention: Philip Modaff, Director of Public Works

Subject: *Village of Carol Stream: WRC Improvements
Sodium Hypochlorite Delivery System Replacement Project*
RECOMMENDATION TO AWARD

Dear Mayor and Board of Trustees:

Bids were received for the subject project on December 15, 2011. The following bids were received:

<u>Bidder</u>	<u>Amount of Bid</u>
Dahme Mechanical, Inc. Arlington Heights, IL 60005	\$154,444
Independent Mechanical, Inc. Northfield, IL 60093	\$157,500
Marc Kresmery Construction LLC Elgin, IL 60123	\$177,474
Kovilic Construction Company Inc. Franklin Park, IL 60131	Not Read

The Engineer's Opinion of Probable Cost was \$190,000.

All bids were reviewed for completeness prior to reading the amount of their bids. Kovilic Construction Company Inc. did not supply the following forms with their bid package:

1. 00 62 04 Illinois Contractor Certification
2. 00 62 07 Substance Abuse Program Prevention Program
3. 00 62 08 Employment of Illinois Workers on Public Works Act



Mr. Philip Modaff
Village of Carol Stream

December 15, 2011
110364.40 Page 2

As a result, Kovilic Construction Company's bid was considered unresponsive and their bid amount was not read aloud.

We have analyzed each of the remaining bids and find Dahme Mechanical, Inc. to be the lowest, responsible, and responsive Bidder.

Based on our prior experience with this bidder, we believe that Dahme Mechanical Inc. is qualified to complete the project. We recommend award of the contract to Dahme Mechanical, Inc. in the amount of \$154,444.

The original bid bonds and bid forms are enclosed for your files. Please advise us of your decision.

Very truly yours,

BAXTER & WOODMAN, INC.
CONSULTING ENGINEERS

A handwritten signature in cursive script that reads "Christopher Buckley".

Christopher Buckley, PE
Project Manager

Enclosure

Cc: Derek Wold, B&W

AGENDA ITEM

H-1 12-19-11

Village of Carol Stream

Interdepartmental Memorandum

DATE: December 12, 2011

TO: Joe Breinig, Village Manager

FROM: Jon Batek, Finance Director

SUBJECT: Transfer of 2011 Volume Cap



The Village, as a home rule unit of government, is permitted to issue private activity bonds (PABs) pursuant to federal and state regulations. PABs are an economic development tool which can be used to assist in securing tax exempt bond financing for the benefit of private entities for "qualified" projects under IRS guidelines. Federal regulations require municipalities to act as a conduit for the issuance of tax-exempt PABs. Under this arrangement, the Village merely lends its name to the issue for the purpose of obtaining tax exempt status, and is not obligated in any way for the repayment of principal and interest on the bonds.

Each January, the Village receives an allocation of "volume cap" or PAB bonding authority, which is determined by the Governor's Office of Management and Budget based on a dollar amount per capita. For 2011, Carol Stream received volume cap in the amount of \$3,803,895 at \$95 per capita for 40,041 residents. If each year's cap is not either used for a local project or specifically reserved or transferred by the municipality to another agency before May 1st, the cap is automatically transferred to the State for its subsequent use. On April 18, 2011, the Village Board reserved its 2011 volume cap without a specific purpose identified at that time.

We recently received the attached request from the Upper Illinois River Valley Development Authority (UIRVDA) asking the Village to transfer its cap for use in projects under their jurisdiction. Historically, transfers of this nature can result in a transaction fee paid to the Village equivalent to 1% of the cap transferred. UIRVDA has expressed willingness to pay the 1% transfer fee to the Village. This would generate up to \$38,039 if all of our cap is subsequently used in connection with a bond financing.

As there is no identified local use for our 2011 volume cap, I would recommend adoption of the attached ordinance which will "cede" this cap to UIRVDA. The proposed ordinance has previously been reviewed by counsel.

Please let me know if you have any questions concerning this proposed action item for the December 19th Village Board meeting.

Ordinance No. _____

**An Ordinance Authorizing the Ceding of
Private Activity Bonding Authority**

Whereas, the Internal Revenue Code of 1986 provides that the amount of private activity bonds that may be issued by the Village of Carol Stream ("Village") as a constitutional home rule unit is equal to its population multiplied by \$95.00; and

Whereas, the Illinois Private Activity Bond Allocation Act (30 ILCS 345/1 et seq.) provides, among other things, that the corporation authorities of any home rule unit may reallocate to a state agency any portion of its unused allocation of volume cap; and

Whereas, the Village of Carol Stream has available year 2011 volume cap and desires to utilize this cap in cooperation with the Upper Illinois River Valley Development Authority (UIRVDA) to support the projects that will create jobs and expand the Village's tax base; and

Whereas, the Village of Carol Stream has reserved its 2011 volume cap pursuant to Ordinance No. 2011-04-12 on or before May 1, 2011;

Now Therefore, be it ordained by the Mayor and Board of Trustees of the Village of Carol Stream, DuPage County, Illinois, in the exercise of its home rule powers as follows:

Section 1. Consent to Reallocate to UIRVDA. The Village hereby agrees to reallocate to the Upper Illinois River Valley Development Authority its 2011 private activity volume bonding cap in the amount of \$3,803,895.00. Said private activity volume bonding cap shall be used to support projects that will provide job opportunities and new investments.

Section 2. Letter of Agreement. The Village Finance Director is hereby authorized to execute a letter of agreement with UIRVDA consenting to such allocation on behalf of the Village as authorized. The Village Finance Director is also hereby authorized to enter into any transfer fee arrangements as the Village deems in its best interests.

Section 3. Maintaining Records. The Village Finance Director is hereby authorized to maintain such record of the allocation for the term of the bonds issued pursuant to such allocation.

Section 4. Notice. The Mayor shall provide notice of such allocation to the Office of the Governor.

Section 5. Effective Date. This ordinance shall be effective from and after its passage.

Passed by the Mayor and Board of Trustees of the Village of Carol Stream, DuPage County, Illinois, this 19th day of December, 2011.

Ayes:

Nays:

Absent:

Approved by the Mayor of the Village of Carol Stream, Illinois, this _____ day of _____, 2011.

Mayor
Village of Carol Stream, Illinois

Attest:

Village Clerk of the
Village of Carol Stream, Illinois
(Published in pamphlet form and posted on the _____ day of _____, 2011.)



The Upper Illinois
River Valley Development
Authority

09/23/2011

633 LaSalle Street • Suite 401 • Ottawa, IL 61350 • Tel: 866-325-7525 • www.uirvda.com

September 22, 2011

The Honorable Frank Saverino
Mayor
Village of Carol Stream
500 N. Gary Ave.
Carol Stream, IL 60188-1811

Dear Mayor Saverino:

The Upper Illinois River Valley Development Authority (UIRVDA) respectfully requests consideration for the transfer of your 2011 Home Rule volume cap to UIRVDA for economic development and housing projects. It is our understanding that the Village has reserved its 2011 volume cap allotment of \$3,803,895. Therefore, the Village can still transfer its volume cap until December 31, 2011. We have mutually benefited from working with other communities that have allowed UIRVDA to successfully issue over \$201,840,000 in bonds that have created over 2,275 jobs.

UIRVDA has developed relationships with home rule communities and other regional development authorities in working together to accommodate the volume cap needs of their projects. Some years, UIRVDA has more projects than volume cap and other years we have more volume cap than projects. We have developed a mutually beneficial relationship between communities, counties and other regional development authorities to graciously share this valuable resource for the benefit of the region. We feel it is fair to help a neighbor that has helped us in the past. The rising tide raises all of the boats.

If the Village of Carol Stream would consider passing an ordinance/resolution transferring their 2011 allocation to UIRVDA, the Village would maintain control of their volume cap until December 31, 2011. Up until this date, if a project should appear that the Village might be interested in pursuing, UIRVDA would be happy to re-transfer Carol Stream's volume cap with no questions. UIRVDA could and would do this with a simple resolution.

UIRVDA has entered into a number of transfer fee agreements with home rule units in 2011. The Authority would be pleased to execute a similar agreement with the Village of Carol Stream in return for the transfer of the Village's 2011 volume cap allocation.

All the transfer fee agreements to date with UIRVDA have been for 1%. For example, if UIRVDA (or any other state authority) utilizes any portion of Carol Stream's volume cap, the Village would receive one percent of whatever portion of volume cap is actually used by UIRVDA to finance a bond transaction. The one percent figure is arbitrary and can be changed if the Village wishes to do so. However, one percent is less onerous on a borrower than a higher amount.

Although UIRVDA was created by State statute, the Authority does not receive an annual appropriation. Thus, UIRVDA is unable to pay any money upfront for a transfer agreement. Instead, after UIRVDA issues bonds to a borrower, it would be agreed by a written document that one fee a borrower must pay at the bond closing is a transfer fee for the amount of the Village's volume cap used for that transaction. In this way, the home rule unit is able to derive revenue from something that probably produces little if any income for the Village.

At the end of the calendar year, volume cap can be carried forward for three years, but once carried forward, it can no longer be transferred. Although it cannot be utilized after December 31, 2011 by Carol Stream if transferred, should UIRVDA or any other state authority use the Village's volume cap during these three carry over years (2012-2014), Carol Stream would still receive the transfer fee as agreed to in any written agreement.

UIRVDA is interested in serving in this capacity in order to develop a relationship with the Village of Carol Stream in order to trade cap in up and down years. We respectfully request if you have no need for the cap this fall that you allow us to use it to benefit the residents of UIRVDA. If the Village is interested, I have taken the liberty of enclosing a draft ordinance for you to review as well as a draft letter to the Governor's Office and sample transfer fee agreement. I am available to meet with any Village official you wish regarding this matter. Please call me at 866-325-7525 if you have any questions. Any correspondence should be mailed to:

UIRVDA Capitol Office
P. O. Box 13112
Springfield, IL 62791

Finally, if the Village decides to proceed with this, please send a copy of the resolution/ordinance, Governor's letter, and transfer fee agreement to the above address. Thank you.

Sincerely,

Andrew Hamilton
Executive Director

Upper Illinois River Valley Development Authority

Serving the Counties of: Bureau, Grundy, Kane, Kendall, LaSalle, Marshall, McHenry and Putnam



The Upper Illinois River Valley Development Authority (UIRVDA) was created by an act of the Illinois Legislature in January of 1990 to assist business development and expansion by providing creative low-interest rate financing. Businesses can generally save 1.00% to 3.00% on their cost of borrowing. Bonds are typically purchased by investment banking firms that place them with mutual funds and insurance companies. The borrower then makes payment directly to the buyer of the bond.

UIRVDA can issue:

- Tax-Exempt Industrial Revenue (Manufacturing) Bonds
- Senior Citizen Housing (Multi Family Housing) Bonds
- Local Government (Public Facilities - Water, Sewer, Streets) Bonds
- Not for Profit (YMCA, Hospital) Bonds
- Solid Waste Disposal (Ethanol) Bonds
- Transportation (Intermodal) Bonds

Board of Directors

Robert Bakewell – Wenona, IL
 Tim Duckworth - DCMS
 James Ghiglieri - Toluca, IL
 Barbara Griffith – McNabb, IL
 Michael Guilfoyle – Mendot, IL
 Dennis Hackett – Morris, IL
 Blake Hobson – Huntley, IL
 Philip McCully – Toluca, IL
 William Meagher – LaSalle, IL
 Greg Meyers – Aurora, IL
 Kevin Olson – Morris, IL
 Thomas Setchell – Ottawa, IL
 John Shaw – Yorkville, IL
 William Steep – Seneca, IL
 Gilbert Tonozzi – Hennepin, IL
 Bob Westover - DCEO
 Jeffrey Wilkins – Yorkville, IL

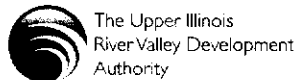

Andrew Hamilton,
 Executive Director
 UIRVDA
 633 LaSalle Street, Suite 401
 Ottawa, IL 61350
 Tel: 866-325-7525
 Fax: 866-325-7569
 Email: andrewjhamilton@uirvda.com

Project	City	Date	Interest*	Amount	Jobs
Waste Recovery	Marseilles	1994	6.00%	\$4,030,000	40
Exolon ESK Co	Hennepin	1996	4.40%	\$8,405,000	80
Exolon ESK Co	Hennepin	1996	6.15%	\$4,595,000	80
General Electric Co	Ottawa	1998	3.80%	\$3,600,000	400
New Heights Recovery	Marseilles	1998	5.40%	\$2,930,000	40
Gemini Acres, LP	Channahon	2000	7.22%	\$22,700,000	100
Clover Technologies	Ottawa	2000	5.20%	\$3,000,000	100
Morris Hospital	Morris	2001	6.05%	\$7,500,000	474
Seneca Grain Co	Seneca	2001	4.90%	\$3,500,000	8
Tri-Con Materials	Hennepin	2001	3.49%	\$1,330,000	30
Advanced Drainage Co	Mendota	2002	4.94%	\$7,000,000	90
Windows Acquisition	Toluca	2002	4.70%	\$1,400,000	70
Plaspros, Inc.	McHenry	2002	4.01%	\$4,935,000	140
Advanced Flexible Inc	Lake in the Hills	2003	4.08%	\$5,500,000	40
Countryside Housing	Yorkville	2004	4.94%	\$6,500,000	5
Streator Dependable	Streator	2004	4.59%	\$3,500,000	20
Illinois Valley YMCA	Peru	2005	3.85%	\$6,000,000	12
Living Springs SLF	McHenry	2007	6.69%	\$12,045,000	38
NIMED Corporation	Huntley	2007	5.96%	\$55,000,000	90
HFH of Illinois	Ottawa	2007	6.49%	\$2,150,000	12
Morris Healthcare	Morris	2007	6.42%	\$8,000,000	50
Olsun Electric	Richmond	2008	7.55%	\$9,000,000	30
Plaspros, Inc.	McHenry	2010	2.73%	\$3,920,000	140
Walsh Automotive	Ottawa	2010	2.76%	\$3,200,000	50
Pleasant View Luther	Ottawa	2010	7.00%	\$16,695,000	215
TOTAL BONDS				\$201,840,000	2,274

*SWAP Rate at Closing



Village of Carol Stream

FRANK SAVERINO, SR., MAYOR • BETH MELODY, CLERK • JOSEPH E. BREINIG, MANAGER
500 N. GARY AVENUE • CAROL STREAM, ILLINOIS 60188-1899
(630) 665-7050 • FAX (630) 665-1064
www.carolstream.org

Carol Stream
© 1996 Village of Carol Stream

December 20, 2011

Mr. Andrew Hamilton
Executive Director
Upper Illinois River Valley Development Authority
P.O. Box 13112
Springfield, IL 62791

Re: LETTER OF AGREEMENT

Dear Mr. Hamilton:

As agreed, please find attached the Village of Carol Stream's adopted Ordinance No. _____ authorizing the transfer and reallocation of its 2011 volume cap to the Upper Illinois River Valley Development Authority (UIRVDA).

Please print, sign and return this letter as a binding agreement between the Village and UIRVDA that if the Village's 2011 volume cap is used by UIRVDA, the Village of Carol Stream shall receive a transfer fee equal to one percent of its transferred volume cap at closing. Upon signing, please return a copy to:

Jon Batek, Finance Director
500 N. Gary Avenue
Carol Stream, IL 60188

Sincerely,

Jon D. Batek, Finance Director

Acknowledged and Agreed:

Andrew Hamilton
Executive Director,



Village of Carol Stream

FRANK SAVERINO, SR., MAYOR • BETH MELODY, CLERK • JOSEPH E. BREINIG, MANAGER
500 N. GARY AVENUE • CAROL STREAM, ILLINOIS 60188-1899
(630) 665-7050 • FAX (630) 665-1064
www.carolstream.org

December 20, 2011

Office of the Governor
Governor's Office of Management and Budget
603 Stratton Building
Springfield, IL 62706

Attention: Debt Management Unit

Re Issuer: Village of Carol Stream

Total 2011 Volume Cap Allocation: \$3,803,895

This letter will serve as confirmation of the allocations granted, transferred or reserved, of the Village's 2011 private activity volume cap in the amount of \$3,803,895 by ordinance previously passed prior to May 1, 2011:

- | | |
|---|--|
| 1. Principal Amount of Issue: | \$3,803,895 |
| Bond Description | Revenue Bonds |
| 2. Total Allocation Granted or Reallocated: | \$3,803,895 |
| Reallocated to: | Upper Illinois River Valley
Development Authority |

See attached ordinance.

Sincerely,

Frank Saverino, Sr., Mayor
Village of Carol Stream

AGENDA ITEM

H-2 12-19-11

Village of Carol Stream INTER-DEPARTMENTAL MEMO

TO: Mayor and Trustees

FROM: Joseph E. Breinig, Village Manager 

DATE: December 14, 2011

RE: BYO Liquor License Classification

Mayor Saverino as Local Liquor Commissioner has been contacted by a current liquor license holder about the feasibility of obtaining a license for "bring your own - BYO" liquor. Patrons would be allowed to carry in beer and wine purchased elsewhere for consumption on the licensed premises. The attached ordinance has been prepared by staff and reviewed by the Village Attorney. In drafting the ordinance similar ordinances were reviewed from DeKalb, Hinsdale, Downers Grove, Bloomingdale and West Chicago.

The proposed ordinance requires purchase and consumption of a meal as a condition for the service of beer and wine only on the premises. Consumption is limited to one 750 ml bottle of wine or 36 ounces of beer per patron. Service of alcohol is limited to the regular hours of operation and only during the hours of regular food service. Alcohol service is to occur indoors only. The premises may only provide glassware and ice and may charge a corkage fee provided that fee is prominently displayed. Partially consumed wine can be removed in a sealed, tamper-proof bag. BASSET training is required for employees performing corkage and/or serving. The ordinance attempts to incorporate the best practices from the other communities.

If approved, the ordinance will create the Class O license. There will be no licenses available. Consistent with past practice, an applicant will need to request a license and the Village Board will need to add a license by ordinance. The fee for the proposed license is \$525 annually.

Staff recommends approval of the attached ordinance.

JEB/td
Attachment

ORDINANCE NO. _____

AN ORDINANCE AMENDING CHAPTER 11 (INTOXICATING LIQUORS), ARTICLE 2 (ALCOHOLIC LIQUOR DEALERS), SECTIONS 11-2-2 AND 11-2-7 CREATING A NEW CLASS O, BRING YOUR OWN LIQUOR LICENSE CLASSIFICATION

BE IT ORDAINED by the Mayor and Board of Trustees of the Village of Carol Stream, DuPage County, Illinois, in the exercise of its home rule powers as follows:

SECTION 1: Chapter 11, Section 11-2-2 of the Carol Stream Code of Ordinances is hereby amended, and as amended shall read as follows:

11-2-2 LICENSED REQUIRED.

(A) It shall be unlawful to sell or offer for sale at retail in the village any alcoholic liquor without having a retail liquor dealer's license, or to sell or offer for sale such alcoholic liquor in violation of the terms of such license.

(B) It shall be unlawful to permit the consumption of alcoholic liquor on the premises of any restaurant business by any person, unless a retail liquor dealer's license has been issued for such premises, and then only in accordance with the terms of such license.

SECTION 2: Chapter 11, Section 11-2-7 of the Carol Stream Code of Ordinances shall be amended by adding thereto subsection (m) which shall read as follows:

11-2-7 CLASSIFICATION OF LICENSES; NUMBER ISSUED; FEES.

(m) Class O Licenses. A Class O license shall authorize the consumption of beer and wine which has been brought onto the premises by a patron or patrons over the age of twenty-one (21) for on-site consumption where the premises is that of a restaurant as defined herein. The following provisions shall apply:

1. Service of alcohol shall be permitted in conjunction with the purchase and consumption of a meal prepared on the premises while seated at a table and served by wait staff.
2. No more than one (1) 750 ml bottle of wine per patron or no more than thirty-six (36) ounces of beer per patron (unopened) shall be permitted to be brought into the premises.
3. Service of alcohol shall be allowed only during the restaurant hours of operation and only along with and during the regular food service and shall not exceed the hours of service of alcohol found in Section 11-2-24 of the Carol Stream Code of Ordinances.

4. Service of alcohol shall be limited to indoor seating only. Under no circumstances shall the service of alcohol be permitted outside unless otherwise permitted by the Carol Stream Code of Ordinances.
5. Licensees may only provide glassware and ice to patrons, may uncork, pour and control its consumption and may charge a corkage fee. The amount of any corkage fee shall be prominently displayed on the establishment's menu.
6. The licensee shall not permit any customer to leave the licensed premises with any open beer or wine container. Partially consumed wine, which has been securely sealed by the licensee, placed into a transparent, one-time use, tamper-proof bag may be removed from the licensed premises. A licensee shall not charge for this service.
7. Only employees who have successfully completed a certified training program may perform corkage/serving duties. Such employees must be at least nineteen (19) years of age and shall serve in accordance with all State and local laws.
8. Licensees are prohibited from storing liquor on the licensed premises, unless otherwise provided by a separate license classification validly held by the licensee.
9. Package and on-site sales of liquor is prohibited, unless otherwise provided by a separate license classification validly held by the licensee.
10. No licensee shall be permitted to charge a cover charge.
11. A Class O license may be issued to a restaurant in valid possession of another license classification.
12. Licensees shall provide a certificate of insurance reflecting coverage for dram shop or equivalent liability for service of alcohol.
13. Licensees shall be liable for violations of this Article in the same manner as the holder of any other classification of liquor license, including but not limited to violations for service to minors and over-serving of patrons.

SECTION 3: The number of Class O licenses authorized for issuance shall be set at zero (0).

SECTION 4: The fee for a Class O license shall be \$525 annually.

SECTION 5: All ordinances or parts of ordinances in conflict with the provisions of this ordinance are hereby repealed to the extent of such conflict.

SECTION 6: If any such section, paragraph, clause or provision of this ordinance shall be held invalid, the invalidity thereof shall not affect any of the other provisions of this ordinance.

SECTION 7: This ordinance shall be in full force and effect after its passage, approval, and publication in the manner provided by law.

PASSED AND APPROVED THIS 19th DAY OF DECEMBER, 2011.

AYES:

NAYS:

ABSENT:

Frank Saverino, Sr., Mayor

ATTEST:

Beth Melody, Village Clerk

AGENDA ITEM

H-3 12-19-11

ORDINANCE NO. _____

**AN ORDINANCE AMENDING CHAPTER 16 OF THE MUNICIPAL CODE
OF THE VILLAGE OF CAROL STREAM
(ZONING CODE)**

**BE IT ORDAINED BY THE MAYOR AND BOARD OF TRUSTEES OF THE
VILLAGE OF CAROL STREAM, DU PAGE COUNTY, ILLINOIS, IN THE EXERCISE
OF ITS HOME RULE POWERS, as follows:**

SECTION 1: That Chapter 16, Article 5, Section 6 of the Carol Stream Zoning Code is hereby amended as follows:

§ 16-5-6 GARY AND NORTH AVENUE CORRIDOR REGULATIONS.

(E) *Application of standards.*

(4) Application of these standards to existing development shall be initiated upon exterior additions to structures or upon significant changes to buildings or property as follows. Whether a change is significant shall be determined by the Community Development Director on the basis of the purpose and intent of the Gary and North Avenue Corridor regulations. as follows:

(a) *Use.* Any changes in the use of an existing building or property shall conform to the standards set forth in § 16-5-6(F), Uses Permitted Within the Gary Avenue and North Avenue Corridors.

(b) *Lot Standards.* Any subdivision or significant change in the size or dimensions of a property shall conform with the standards set forth in § 16-5-6(G), Lot Standards.

(c) *Access.* Any significant change to the access between the site and Gary Avenue or North Avenue shall conform with the standards set forth in § 16-5-6(H), Access.

(d) *Site Design, Grading and Drainage.* Any significant change in the grading or drainage on the site shall conform with the standards set forth in § 16-5-6(I), Site Design, Grading and Drainage, and § 16-5-6(M), Landscape Design and Site Furnishings.

(e) *Setbacks.* Any building addition or other significant change in the building setback shall conform with the standards set forth in § 16-5-6(J), Required Setbacks and the open space and adjacent setback area shall conform with § 16-5-6(M), Landscape Design and Site Furnishings.

(f) *Architectural Design.* Any significant change in the building facade design such as changes in the location or types of windows, doors or other features, shall conform with the standards set forth in § 16-5-6(K), Architectural Design and § 16-5-6(J), Required Setbacks. Painting or repair of the existing façade, a minor addition of windows or doors, or a minor modification of windows or doors shall not constitute a significant change, provided the Community Development Director determines that such alterations do not violate the purpose and intent of the Gary and North Avenue Corridor Regulations.

(g) *Parking.* Any significant addition to or reconstruction of parking spaces shall conform with the standards set forth in § 16-5-6(L), Parking and § 16-5-6(M), Landscape Design and Site Furnishings. With the addition of new parking areas equal to or greater than the number of spaces existing prior to adoption of this section, existing parking areas shall be required to be screened with landscape material in accordance with § 16-5-6(L)(3)(c).

SECTION 2: That Chapter 16, Article 16, Section 5 of the Carol Stream Zoning Code is hereby amended as follows:

§16-16-5 CHANGES AND MODIFICATIONS OF THE PLANNED UNIT DEVELOPMENT AFTER APPROVAL OF THE FINAL PLAN.

(A) After the approval of the final plan, the use of land and the construction, modification, or alteration of any buildings or structures within the planned unit development will be governed by the approved final plan.

(B) No changes may be made in the approved final plan, except upon application ~~to the appropriate agency~~ for village approval according to the following procedure:

(1) ~~During~~ Prior to or during the construction of the planned unit development, the procedure shall be as follows:

(a) Minor changes. Minor changes in the location, siting, and height of buildings and structures, and in the location of streets and ways of public access and in the size and location of open space, may be authorized by the ~~Plan Commission~~ Community Development Director as required by engineering or other circumstances not foreseen at the time that the final plan was approved. Whether an alteration constitutes a minor change to an approved planned development plan shall be determined by the Community Development Director in accordance with all of the following criteria:

1. Does not alter the concept or intent of the planned unit development;

2. Does not violate an adopted development agreement;

3. Does not increase the density of the development;
4. Does not result in any deviations from village standards for the underlying zoning district;
5. Does not result in a significant change in the size or location of any building;
6. Does not change the use of the site;
7. Does not result in a significant increase in building height;
8. Does not reduce open space by more than ten percent from the original planned unit development plan;
9. Does not change the proportion of housing types by more than 15%; and
10. Does not result in a significant change in road standards or locations.

(b) Major changes. All changes in land uses, any rearrangement of lots, blocks, and building tracts, any major changes in the provision for common open space and all other changes in approved final plans not classified by §16-16-5(B)(1)(a) as minor changes shall be considered to be major changes to the approved planned unit development plan, and must be made approved by the Village Board under the procedures authorized by the zoning ordinance for an amendment to the zoning map.

(c) If major changes are allowed in a final site plan, a new site plan reflecting such changes shall be filed with the village. Any major changes which are approved for the final plan may be recorded.

(2) After the completion of the construction of the planned unit development, the procedure shall be as follows:

(a) Minor changes. Minor changes to an approved planned unit development plan, as defined by §16-16-5(B)(1)(a) and including any Any minor extensions, alterations, or modifications of existing buildings or structures, may be authorized by the Plan Commission Community Development Director, if they are consistent with the purpose and intent of the final plan.

(b) Any building or structure that is totally or substantially destroyed may be reconstructed only in compliance with the final plan unless an amendment to the final plan is approved following the procedures for an amendment to the zoning map.

(c) Major changes. All changes in the final plan other than those classified as minor changes ~~in the final plan~~ must be made approved by the Village Board under the procedure authorized by the zoning ordinance for an amendment of the zoning map. ~~No changes may be made in the final plan, unless they are required for the continued successful functioning of the planned unit development, or unless they are required by changes in conditions that have occurred since the final plan was approved or by changes in the development policy of the village.~~

This Ordinance shall be in full force and effect from and after passage, approval and publication in pamphlet form as provided by law.

PASSED AND APPROVED THIS 19th DAY OF December, 2011.

AYES:

NAYS:

ABSENT:

Frank Saverino, Sr. Mayor

ATTEST:

Beth Melody, Village Clerk

Village of Carol Stream

Interdepartmental Memo

TO: Joe Breinig

REVIEWED BY: Chief Kevin Orr

FROM: DC E. Sailer

DATE: 12/12/2011

RE: **The Police Department requests the Village Board adopt the attached Drug Paraphernalia Ordinance banning the use and possession of these items.**

With the attention being given to recent developments with cannabis, illegal drugs and synthetic substances, I believe this is a good time to enact a drug paraphernalia ordinance. Most surrounding towns have such an ordinance. The ordinances are similarly worded and taken directly from the Illinois Compiled statutes.

This ordinance would allow officers to hold people accountable for possessing such equipment when the evidence of cannabis or other illegal substance is not present. It would provide officers another option when dealing with persons suspected of illegal activity.

This ordinance would have the support of citizens and certain advocacy groups. An ordinance would allow officers to arrest people that ingest compounds that are not banned by law if they use paraphernalia to ingest the compounds. Mere possession of drug paraphernalia does not require any laboratory test. An ordinance would relieve apprehension about banning all types of substances and provide us with a tool to take enforcement action and hold people accountable.

Village Attorney James Rhodes drafted the enclosed ordinance.

The fine will be a minimum of \$750, which mirrors State law.

I request the Village Board to adopt the attached drug paraphernalia ordinance.

ORDINANCE NO. _____

**AN ORDINANCE AMENDING CHAPTER 14, (GENERAL OFFENSES), ARTICLE 2
(OFFENSES AGAINST PERSONS), ADDING SECTIONS 14-2-32 (DRUG
PARAPHERNALIA)**

BE IT ORDAINED by the Mayor and Board of Trustees of the Village of Carol Stream, DuPage County, Illinois, in the exercise of its home rule powers as follows:

SECTION 1: Chapter 14, Article 2 of the Carol Stream Code of Ordinances is hereby amended by adding Section 14-2-32 of the Carol Stream Code of Ordinances which shall read as follows:

Section 14-2-32 Drug Paraphernalia

(A) As used in this section, unless the context otherwise requires:

(1) The term "cannabis" shall have the meaning ascribed to it in Section 3 of the "Cannabis Control Act", 720 ILCS 550/3, as if that definition were incorporated herein.

(2) The term "controlled substance" shall have the meaning ascribed to it in Section 102 of the "Illinois Controlled Substances Act", 720 ILCS 570/102, as if that definition were incorporated herein.

(3) "Deliver" or "delivery" means the actual, constructive or attempted transfer of possession, with or without consideration, whether or not there is an agency relationship.

(4) "Drug paraphernalia" means all equipment, products and materials of any kind which are intended to be used unlawfully in planting, propagating, cultivating, growing, harvesting, manufacturing, compounding, converting, producing, processing, preparing, testing, analyzing, packaging, repackaging, storing, containing, concealing, injecting, ingesting, inhaling or otherwise introducing into the human body cannabis or a controlled substance in violation of the "Cannabis Control Act" 720 ILCS 550/1 et seq., the "Illinois Controlled Substances Act" 720 570/100 et seq., or the "Methamphetamine Control and Community Protection Act" 620 ILCS 646/1 et seq. It includes, but is not limited to:

(a) Kits intended to be used unlawfully in manufacturing, compounding, converting, producing, processing or preparing cannabis or a controlled substance;

(b) Isomerization devices intended to be used unlawfully in increasing the potency of any species of plant which is cannabis or a controlled substance;

(c) Testing equipment intended to be used unlawfully in a private home for identifying or in analyzing the strength, effectiveness or purity of cannabis or controlled substances;

(d) Diluents and adulterants intended to be used unlawfully for cutting cannabis or a controlled substance by private persons;

(e) Objects intended to be used unlawfully in ingesting, inhaling, or otherwise introducing cannabis, cocaine, hashish, hashish oil, methamphetamine or other controlled substances, as defined by law, into the human body including, where applicable, the following items:

- (i) Water pipes;
- (ii) Carburetion tubes and devices;
- (iii) Smoking and carburetion masks;
- (iv) Miniature cocaine spoons and cocaine vials;
- (v) Carburetor pipes;
- (vi) Electric pipes;
- (vii) Air-driven pipes;
- (viii) Chillums;
- (ix) Bongs;
- (x) Ice pipes or chillers;
- (xi) Glass pipes.

(xii) Any item whose purpose, as announced or described by the seller, is for use in violation of this Act.

(B) No person shall keep for sale, offer for sale, sell, or deliver for any commercial consideration any item of drug paraphernalia.

(C) Any store, place, or premises from which or in which any item of drug paraphernalia is kept for sale, offered for sale, sold, or delivered for any commercial consideration is declared to be a public nuisance.

(D) In addition to any other penalties already provided for by law and this division, a person or store owner convicted of selling drug paraphernalia shall be subject to having their license to sell tobacco revoked, as provided by Section 10-1-13 of the Village of Carol Stream Code of Ordinances.

(E) No person shall knowingly possess an item of drug paraphernalia with the intent to use it in ingesting, inhaling, or otherwise introducing cannabis or a controlled substance into the human body, or in preparing cannabis or a controlled substance for that use. This subsection (a) does not apply to a person who is legally authorized to possess hypodermic syringes or needles under the Hypodermic Syringes and Needles Act.

(F) In determining intent under subsection (E), the trier of fact may take into consideration the proximity of the cannabis or controlled substances to drug paraphernalia or the presence of cannabis or a controlled substance on the drug paraphernalia.

(G) This division shall not apply to the following:

(1) Items used in the preparation, compounding, packaging, labeling, or other use of cannabis or a controlled substance as an incident to lawful research, teaching, chemical analysis, use in law enforcement activities and which is not offered for sale.

(2) Items historically and customarily used in connection with, the planting, propagating, cultivating, growing, harvesting, manufacturing, compounding, converting, producing, processing, preparing, testing, analyzing, packaging, repackaging, storing, containing, concealing, injecting, ingesting, or inhaling of tobacco or any other lawful substance.

Items exempt under this subsection include, but are not limited to, garden hoes, rakes, sickles, baggies, tobacco pipes, and cigarette-rolling papers.

(3) Items which are used for decorative purposes, when such items have been rendered completely inoperable or incapable of being used for any illicit purpose prohibited by this Act.

(4) A person who is legally authorized to possess hypodermic syringes or needles under the Hypodermic Syringes and Needles Act.

In determining whether or not a particular item is exempt under this subsection, the trier of fact should consider, in addition to all other logically relevant factors, the following:

(a) The general, usual, customary, and historical use to which the item involved has been put;

(b) Expert evidence concerning the ordinary or customary use of the item and the effect of any peculiarity in the design or engineering of the device upon its functioning;

(c) Any written instructions accompanying the delivery of the item concerning the purposes or uses to which the item can or may be put;

(d) Any oral instructions provided by the seller of the item at the time and place of sale or commercial delivery;

(e) Any national or local advertising concerning the design, purpose or use of the item involved, and the entire context in which such advertising occurs;

(f) The manner, place and circumstances in which the item was displayed for sale, as well as any item or items displayed for sale or otherwise exhibited upon the premises where the sale was made;

(g) Whether the owner or anyone in control of the object is a legitimate supplier of like or related items to the community, such as a licensed distributor or dealer of tobacco products;

(h) The existence and scope of legitimate uses for the object in the community.

(H) Any person violating the provisions of this ordinance shall be fined not less than \$750.

SECTION 2: All ordinances or parts of ordinances in conflict with the provisions of this ordinance are hereby repealed to the extent of such conflict.

SECTION 3: If any such section, paragraph, clause or provision of this ordinance shall be held invalid, the invalidity thereof shall not affect any of the other provisions of this ordinance.

SECTION 4: This ordinance shall be in full force and effect after its passage, approval, and publication in the manner provided by law.

PASSED AND APPROVED THIS 19th DAY OF DECEMBER, 2011.

AYES:

NAYS:

ABSENT:

Frank Saverino, Sr., Mayor

ATTEST:

Beth Melody, Village Clerk

AGENDA ITEM

H-5 12-19-11

Village of Carol Stream Interdepartmental Memo

TO: Village Manager Joe Breinig

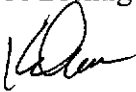
FROM: Chief Kevin Orr 

DATE: December 14, 2011

RE: The Police Department requests that the Village Board adopt the attached Synthetic Alternative Drugs ordinance banning the sale, delivery, possession and use of these products within the Village of Carol Stream.

Synthetic cannabis products have become very popular among teens and young adults as an alternative to marijuana. This is due to the fact that these products can be purchased in retail stores and over the Internet. Many of the products containing these synthetic chemicals are not banned by the State. Although the ordinance will not ban these chemicals, it will ban the sale, delivery, possession and use of the products, by brand names, which contain the chemicals. The ordinance we adopt is very similar to those recently adopted in other communities, namely, West Chicago, North Aurora and Sugar Grove. Village Attorney James Rhodes drafted the ordinance.

In order to enforce the ordinance, officers will arrest anyone that offers for sale, delivers, possesses or uses any product that is listed in the appendix of the ordinance. No testing of the product will be required because enforcement is based solely on the brand name of the product.

A penalty for a violation of any provision of the ordinance includes a fine of not less than \$750. An additional provision has been added for businesses that violate the sale provision which includes the fine plus the possibility of suspension or revocation of their business license.

Should the ordinance be adopted at the December 19th Village Board Meeting, Special Operations personnel will visit each business that sells tobacco products in Carol Stream on December 20th, deliver a copy of the ordinance, check for banned products and require removal if any are present. We will then perform periodic undercover compliance checks beginning shortly thereafter.

ORDINANCE NO. _____
AN ORDINANCE AMENDING THE CODE OF ORDINANCES OF THE
VILLAGE OF CAROL STREAM - WITH RESPECT TO SYNTHETIC
ALTERNATIVE DRUGS

WHEREAS, the Village of Carol Stream (hereinafter the "Village") is a home-rule municipality pursuant to Article VII, Section 6, of the Constitution of the State of Illinois of 1970, and, subject to the specific limitations of Illinois law, may exercise any power and perform any function pertaining to its government and affairs; and

WHEREAS, the Village is empowered, pursuant to Sections 11-42-5, 11-60-1 and 11-60-2, 65 ILCS 5/11-42-5, 11-60-1 and 11-60-2, and its home-rule authority to regulate, license and abate within its boundaries the sale, delivery, possession and use of products being sold at commercial businesses within its corporate boundaries containing compounds originally designed as synthetic alternatives (*i.e.*, synthetic cannabinoids, synthetic stimulants and/or synthetic psychedelic/hallucinogens) to prohibited controlled substances such as tetrahydrocannabinol (THC), cathinone, methcathinone, MDMA and MDEA; and

WHEREAS, the Village finds that products containing synthetic cannabinoids, synthetic stimulants and synthetic psychedelic/hallucinogens are particularly attractive to children and young adults due to their availability in small packages at neighborhood stores at minimal costs, as well as due to the names being given to these substances which are intended to appeal to children and young adults; and

WHEREAS, the Drug Enforcement Administration ("DEA") has determined that the consumption of synthetic cannabinoids can have adverse health effects such as agitation, anxiety, nausea, vomiting, tachycardia, elevated blood pressure, tremors, seizures, hallucinations, paranoid behavior and non-responsiveness; and

WHEREAS, the DEA has further determined that consumption of synthetic stimulants affect alertness, and have been linked to severe psychotic episodes, increased heart rates, panic attacks, and hallucinations; and

WHEREAS, the Village of Carol Stream is also aware of fatal overdoses in Carol Stream and other Illinois communities and in other States, which are believed to have resulted from the users' consumption of synthetic stimulants, cannabinoids or psychedelic/hallucinogens; and

WHEREAS, the Village of Carol Stream deems it necessary and desirable to prohibit the sale, delivery, possession and use of products containing synthetic cannabinoids, synthetic stimulants and synthetic psychedelic/hallucinogens in order to protect the public health, safety and welfare of the citizens of Carol Stream.

NOW, THEREFORE, BE IT ORDAINED by the President and Board of Trustees of the Village of Carol Stream, DuPage County, Illinois, in the exercise of its home rule authority, as follows:

Section 1. The foregoing recitals are hereby incorporated by reference as if set forth hereof.

Section 2. Chapter 14, Article 2 of the Code of Ordinances of the Village of Carol Stream is hereby amended by adding a new Section 14-2-33 which shall read as follows:

"Sec. 14-2-32. Synthetic Alternative Drugs.

(A) *Definitions.* For purposes of this article, the following definitions shall apply unless the context clearly indicates or requires different meaning:

(1) *Deliver or delivery* means the actual, constructive or attempted transfer of possession, with or without consideration, whether or not there is an agency relationship.

(2) *A product containing a synthetic alternative drug* means any product containing a synthetic cannabinoid, stimulant or psychedelic/hallucinogen, as those terms are defined herein.

(3) *Synthetic cannabinoid* means any laboratory-created compound that functions similar to the active ingredient in marijuana, tetrahydrocannabinol (THC), including, but not limited to, any quantity of a natural or synthetic material, compound, mixture, preparation, substance and their analog (including isomers, esters, ethers, salts, and salts of isomers) containing a cannabinoid receptor agonist, such as:

- (a) JWH-007 (1-pentyl-2-methyl-3-(1-naphthoyl)indole)
- (b) JWH-015 ((2-Methyl-1-propyl-1H-indol-3-yl)-1-naphthalenylmethanone)
- (c) JWH-018 (1-pentyl-3-(1-naphthoyl)indole)
- (d) JWH-019 (1-hexyl-3-(naphthalen-1-oyl)indole)
- (e) JWH-073 (naphthalen-1-yl-(1-butylindol-3-yl)methanone)
- (f) JWH-081 (4-methoxynaphthalen-1-yl-(1-pentylindol-3-yl)methanone)
- (g) JWH-098 (4-methoxynaphthalen-1-yl-(1-pentyl-2-methylindol-3-yl)methanone)
- (h) JWH-I22 (1-Pentyl-3-(4-methyl-1-naphthoyl)indole)
- (i) JWH-164 (7-methoxynaphthalen-1-yl-(1-pentylindol-3-yl)methanone)
- (j) JWH-200 (1-(2-morpholin-4-ylethylindol-3-yl)-naphthalen-1-ylmethanone)
- (k) JWH-203 (2-(2-chlorophenyl)-1-(1-pentylindol-3-yl)thanone)
- (l) JWH-210 (4-ethylnaphthalen-1-yl-(1-pentylindol-3-yl)methanone)
- (m) JWH-250 (1-pentyl-3-(2-methoxyphenylacetyl)indole)
- (n) JWH-251 (1-pentyl-3-(2-methylphenylacetyl)indole)
- (o) JWH-398 (1-pentyl-3-(4-chloro-1-naphthoyl)indole)
- (p) HU-210((6aR,10aR)-9-(Hydroxymethyl)-6,6-dimethyl-3-(2-methyloctan-2-yl)-6a,7,10,10a-tetrahydrobenzo [c]chromen-1-ol)
- (q) HU-211 ((6aS, 10aS)-9-(Hydroxymethyl)-6,6-dimethyl-3-(2-methyloctan-2-yl)-6a,7,10,10a-tetrahydrobenzo [c]chromen-1-ol)
- (r) HU-308 ([1R,2R,5R)-2,4,6-dimethoxy-4-(2-methyloctan-2-yl)phenyl]-7,7-dimethyl-4-bicyclo[3.1.1]hept-3-enyl] methanol)
- (s) HU-331 ((3-hydroxy-2-[(1R,6R)-3-methyl-6-(1-methylethenyl)-2-cyclohexen-1-yl]-5-pentyl-2,5-cyclohexadiene-1,4-dione)

- (t) CP 55,940 (2-[(1R,2R,5R)-5-hydroxy-2-(3-hydroxypropyl) cyclohexyl]-5-(2-methyloctan-2-yl)phenol)
- (u) CP 47,497 (2-[(1R,3S)-3-hydroxycyclohexyl]-5-(2-methyloctan-2-yl)phenol) and its homologues
- (v) WIN 55,212-2((R)-(+)-[2,3-Dihydro-5-methyl-3-(4-morpholinylmethyl)pyrrolo [1,2,3-de)-1,4- benzoxazin-6-yl]-1- naphthalenylmethanone)
- (w) RCS-4 ((4-methoxyphenyl)(1-pentyl-1H-indol-3-yl)methanone)
- (x) RCS-8(1-(1-(2-cyclohexylethyl)-1H-indol-3-yl)-2-(2-methoxyphenyl)ethanone)

(4) *Synthetic stimulant* means any compound that mimics the effects of any federally controlled Schedule I substance such as cathinone, methcathinone, MDMA and MDEA, including, but not limited to, any quantity of a natural or synthetic material, compound, mixture, preparation, substance and their analog (including salts, isomers, and salts of isomers) containing substances which have a stimulant effect on the central nervous system, such as:

- (a) 3-Fluoromethcathinone
- (b) 4-Fluoromethcathinone (other name: flephedrone)
- (c) 3,4-Methylenedioxy-methcathinone (other name: methylone, MDMC)
- (d) 3,4-Methylenedioxy-pyrolvalerone (other name: MDPV)
- (e) 4-Methylmethcathinone (other names: mephedrone, 4-MMC)
- (f) 4-Methoxymethcathinone (other names: methedrone, bk-PMMA, PMMC)
- (g) 4-Ethylmethcathinone (other name: 4-EMC)
- (h) Ethcathinone
- (i) Beta-keto-N-methylbenzodioxolylpropylamine (other names: butylone, bk-MBDB)
- (j) Naphthylpyrovalerone (other names: naphyrone, NRG-1)
- (k) N,N-dimethylcathinone (other name: metamfepramone)
- (l) Alpha-pyrrolidinopropiophenone (other name: alpha-PPP)
- (m) 4-methoxy-alpha-pyrrolidinopropiophenone (other name: MOPPP)
- (n) 3,4-methylenedioxy-alpha-pyrrolidinopropiophenone (other name: MDPPP)
- (o) Alpha-pyrrolidinovalerophenone (other name: alpha-PVP)
- (p) 6,7-kihydro-5H-indeno(5,6-d)- 1,3-dioxal-6-amine) (other name: MDAI)
- (q) Any compound that is structurally derived from 2-amino-1-phenyl-1-propanone by modification or substitution in any of the following ways:
 - (i) in the phenyl ring to any extent with alkyl, alkoxy, alkylendioxy, haloalkyl, or halide substituents, whether or not further substituted in the phenyl ring by one or more other univalent substituents;
 - (ii) at the 3-position with an alkyl substituent;
 - (iii) at the nitrogen atom with alkyl, dialkyl, benzyl, or methoxybenzyl groups; or
 - (iv) by inclusion of the nitrogen atom in a cyclic structure.

(5) *Synthetic psychedelic/hallucinogen* means any compound that mimics the effects of any federally controlled Schedule I substance, including but not limited to, any quantity of a natural or synthetic material, compound, mixture, preparation, substance and their analog (including salts, isomers, esters, ethers and salts of isomers) containing substances which have a psychedelic/hallucinogenic effect on the central nervous system and/or brain, such as:

- (a) 2-(2,5-Dimethoxy-4-ethylphenyl)ethanamine (2C-E);
- (b) 2-(2,5-dimethoxy-4-methylphenyl)ethanamine (2C-D);
- (c) 2-(4-Chloro-2,5-dimethoxyphenyl)ethanamine (2C-C);
- (d) 2-(4-Iodo-2,5-dimethoxyphenyl)ethanamine (2C-I);
- (e) 2-(4-(Ethylthio)-2,5-dimethoxyphenyl)ethanamine (2C-T-2);
- (f) 2-(4-(Isopropylthio)-2,5-dimethoxyphenyl)ethanamine (2C-T-4);
- (g) 2-(2,5-Dimethoxyphenyl)ethanamine (2C-H);
- (h) 2-(2,5-Dimethoxy-4-nitro-phenyl)ethanamine (2C-N);
- (i) 2-(2,5-Dimethoxy-4-(n)-propylphenyl)ethanamine (2C-P).

(B) *Sale or delivery unlawful.* No person shall sell, offer for sale or deliver any product containing a synthetic cannabinoid, a synthetic stimulant or a synthetic psychedelic/hallucinogen including, but not limited to, those products set forth in Subsection (E).

(C) *Possession unlawful.* No person shall knowingly possess a product containing a synthetic cannabinoid, a synthetic stimulant or a synthetic psychedelic/hallucinogen, and including but not limited to those products set forth in Subsection (E).

(D) *Use unlawful.* It shall be unlawful for any person to be under the influence of a synthetic cannabinoid, a synthetic stimulant or a synthetic psychedelic/hallucinogen.

(E) The following products have been determined to contains synthetic cannabinoid, synthetic stimulus or synthetic psychedelic/hallucinogen:

POW	Wicked X	XTREME Spice
Spice Gold	K2 Summit	Stinger
Swagger Grape	Love Strawberry	Pulse
Spice Gold	Shanti Spice Blueberry	Mystery
Pulse	Aztec Midnight Wind	Bad 2 the Bone
Black Mamba	Tezcatlipoca	Dragon Spice
Naughty Nights	Sativah	Samurai Spirit
K2 Watermelon	Mid-Atlantic Exemplar	Buzz
Black Mamba	(K2 Summit)	Midnight Chill
Green Monkey Chronic Salvia	Aztec Gold	K Royal
Voodoo Remix	K2 Summit	Spicylicious
G Greenies Caramel Crunch	Ultra Cloud 10	Shanti Spice
Black Diamond	Colorado Chronic	K3 Grape
Blueberry Hayze	K3 Kryptonite	K3 Strawberry
Eruption Spice	Funky Monkey XXXX	K3 Blueberry
Love Strawberry	K2 Blue	Earthquake
Voodoo Child	K2 Blonde	Ocean Blue
Mid-Atlantic Exemplar	K2 Pink	G Four
K2 Summit	K2 Citron K2	Wood Stock
Magic Dragon Platinum	Mellon K2	K3 Legal
Fire Bird Ultimate	Pineapple	Who Dat

Strength Cinnamon	K2 Standard	Dark Night II
Nitro	K2 Summit	Spike 99 Ultra
Black Magic Salvia	Si. S Werve	2010
Black Mamba	Chronic Spice	Zombie World
K2 Strawberry	K3 Mango	SYN Swagg
K2 Blueberry	K3 Original	SYN Smooth
SYN Spearmint	Magic Spice	SYN Incense Smooth
SYN Spearmint #2	Voodoo Magic	SYN Incense Spearmint
SYN Chill	Texas Gold	SYN Incense LemonLime
SYN Suave	Demon	Super Summit
Heavenscent Suave	K3	D-Rail
SYN Vanilla	K2 Pink Panties	K2 Peach
SYN Vanilla #2	Heaven Improved	Funky Monkey
SYN Lemon Lime	K3 Sun	K2 Summit Coffee Work
SYN Lemon Lime #2	K3 Dusk	K3 Legal - Original (Black)
New K3 Improved	K3 Original Improved	K3 Legal - Sun (Black)
C4 Herbal Incense	K2 Summit	K3 Legal - Sea (silver)
New Improved K3 Cosmic Blend	New K3 Heaven	K3 Legal - Earth (silver)
New Improved K3 Dynamite	New K3 Earth	K2 Cloud 9
New Improved K3 Kryptonite	New K3 Sea Improved	Greenies Strawberry
Utopia	New-Kron Bomb	K2 Blonde
Utopia-Blue Berry	Cherry Bomb	K2 Standard
Euphoria	Rebel Spice	K2 Citron
Who Dat Herbal Incense	Mega Bomb	K2 (unknown variety)
Love Potion 69	Mr. Smiley's	K2 Summit Space
Legal Eagle	Summer Skyy	K2 Blue
K2 Standard	Moe Joe Fire	K2 Pink
Super Kush	Fully Loaded	K2 Latte
Bayou Blaster	Da Block	K2 Mint
Paradise	Back Draft	K2 Silver
Red Bird	K1 Orbit	K2 Peach
K1 Gravity	C3	Spike Gold
Spike Maxx	Banana Cream Nuke	Humboldt Gold
Spike Diamond	K4 Silver	K2 Orisha Regular
Spike Silver	K4 Gold	K2 Orisha Max
K2 Strawberry	K3 Heaven Improved	K2 Orisha Super
K2 Pineapple Express	K3 Heaven Legal	K2 Amazonian Shelter
K2 Blueberry	K3 Sun Legal	K2 Solid Sex on the Mountain
K2 Pink	K3 Sun Improved	Midnight Chill
K2 Blonde	K3 Kryptonite	Unknown cigarette
K2 Summit	K3 XXX	Freedom
K2 Citron	K3 Cosmic Blend	K2 Sex
K2 Ultra	K3 Original	K2 Orisha White Magic Super

K2 Blue	C4	K2 Orisha Black Magic Max
MNGB Tropical Thunder	K1 Gravity	K2 Thai Dream
MNGB Pinata Colada	K1 Orbit	K4 Bubble Bubble
MNGB Almond/Vanilla	K2 Pina Colada	MTN-787
MNGB Peppermint	K3 Kryptonite	K2 Kryptonite
MNGB Spear Mint	K3 XXX	Legal Eagle Apple
p.e.p. pourri Twisted Vanilla	K3 Cosmic Blend	Pie K4 Purple Haze
p.e.p. pourri Original Spearmint	K3 Original	K4 Summit Remix
p.e.p. pourri Love Strawberry	Rasta Citrus Spice	8-Ball
p.e.p. pourri X Blueberry	Kind Spice	C4
K2 Summit	Time Warp	K2
Voo Doo Remix (orange package)	Rasta Citrus Spice	Tribal Warrior
Voo Doo Remix (black package)	Pink Tiger	Spike99
exSES	Spice Gold	Spice Gold
Yucatan Fire Smoke	Cill Out	Spice Diamond
Skunk	Smoke	Spice Silver
Sense	Forest Humus	Genie
EX-SES Platinum Blueberry	Scope Vanilla	Spike 99
EX-SES Platinum Cherry	Scope Wildberry	Jamaican Gold
EX-SES Platinum Strawberry	Chill X	Potpourri
EX-SES Platinum Vanilla	Space	Winter Boost
Magic Silver	Silent Black	Citrus
Spice Artie Synergy	Sence	Spice Gold
Spice Diamond	Smoke	Spicey XXX
Spice Gold	Caneff	Spike 99
Spice Tropical Synergy	Spice Gold	Ex-SES Platinum
Spicey Regular XXX Bluebeny	Gold Spirit Spice	Magic Gold
Spicey Regular XXX Strawberry	Yucatan Fire	Bombay Blue
Spicey Ultra Strong XXX Vanilla	Spice Diamond	Dream
Spicey Ultra Strong XXX	Smoke Plus	Spice Tropical Synergy
Spike 99 Ultra Blueberry	Magic Silver	Diamond Spirit
Spike 99 Ultra Cherry	Mojo	Platinum Strawberry
Spike 99 Ultra Strawberry	EX-SES	Spicey Ultra Strong XXX Vanilla
Spike 99 Ultra Strawberry		

(F) *Penalty.* Violation of any provision of this Section shall result in a fine of not less than seven hundred fifty dollars (\$750.00) for each such offense. Each violation of this Section, or everyday a violation continues to exist, shall constitute a new and separate violation.

(G) In addition to any other penalties provided by law and this Code, any person or store owner convicted of selling any product containing synthetic cannaboid, synthetic stimulant or synthetic psychedelic/hallucinogen shall be subject to having their business license suspended or revoked as provided in Section 10-1-13 of the Village of Carol Stream Code of Ordinances.

Section Three: That all ordinances and resolutions, or parts thereof in conflict with the provisions of this Ordinance are, to the extent of such conflict, hereby repealed.

Section Four: That this Ordinance shall be in full force and effect from and after its adoption, approval and publication in pamphlet form as provided by law.

PASSED AND APPROVED THIS _____ DAY OF _____, 2011.

Frank Saverino, Sr., Mayor

ATTEST:

Beth Melody, Village Clerk



Carol Stream Police Department
Intradepartmental Memo

TO: Village Manager Joe Breinig

FROM: Chief Kevin Orr 

DATE: December 14, 2011

RE: The Police Department requests the Village Board adopt an amendment to Section 8-1-2, Penalties and Related Provisions, of the Carol Stream Code of Ordinances to mirror State Statute fine amounts.

After reviewing Village Ordinance 2004-10-56, it was discovered that our fine amounts under *Section 8-1-2: Penalties and Related Provisions* do not mirror the State Statute (730 ILCS 5/5-4.5-55-75) fine amounts. I request that the Village Board adopt an amended ordinance that mirrors the current State Statute fine structure.

I have outlined below the current and proposed fine structures.

Proposed Increases to the Village Ordinance Fine Amounts

<u>Current Fine Amount</u>	<u>Minimum</u>	<u>Maximum</u>
Class A Misdemeanors	\$1,000.00	\$1,500.00
Class B Misdemeanors	\$300.00	\$500.00
Class C Misdemeanors	\$150.00	\$500.00
Petty/ Business Offenses	\$75.00	\$1,000.00
Second Offender Fee	\$1,500.00	n/a
BAC .150 or higher	\$500.00	n/a

<u>Proposed Fine Amount</u>	<u>Minimum</u>	<u>Maximum</u>
Class A Misdemeanors	\$1,000.00	\$2,500.00
Class B Misdemeanors	\$300.00	\$1,500.00
Class C Misdemeanors	\$150.00	\$1,500.00
Petty/ Business Offenses	\$60.00	\$1,000.00
Second Offender Fee	\$2,000.00	n/a
BAC .160 or higher	\$500.00	n/a

I am also proposing the Village Board adopt State Statue 625 5/11-501.01(i) under the Code of Ordinances. This statute allows a public agency to request restitution (up to \$1,000.00 per incident) for a DUI related incident requiring an emergency response. This amendment will allow the Village to recoup costs associated with emergency response to DUI incidents where the offended is convicted of the charge. The emergency response restitution provision is common with other communities that locally prosecute DUIs.

Restitution Cost Amounts

Number of Community Service Technician(s) responded.. ____ X \$30.00 per hour X ____ hours = _____.

Number of Police Officer(s) responded..... ____ X \$42.00 per hour X ____ hours = _____.

Number of Police Sergeant(s) responded..... ____ X \$50.00 per hour X ____ hours = _____.

Number of police vehicle(s) responded..... ____ X \$16.25 per hour X ____ hours = _____.

Total amount of restitution \$ _____.

Another addition is the creation of a fee in the amount of \$50 for Equipment and the Handling of Drug Samples. This would allow for the Village to recoup costs incurred for the equipment used to collect and handle urine samples used for DUI Drug related offenses. This provision is also common with other communities that locally prosecute DUIs.

These updates and additions have been reviewed by both Village Attorney James Rhodes and DUI Prosecutors Ilene Schiavone and Tom Howard.

ORDINANCE NO. _____

AN ORDINANCE AMENDING SECTION 8-1-2, PENALTIES AND RELATED PROVISIONS OF THE CAROL STREAM CODE OF ORDINANCES

WHEREAS, the Mayor and Board of Trustees have heretofore adopted Section 8-1-2 of the Carol Stream Code of Ordinances establishing penalties for any offenses or violations of Village ordinances classified as petty offenses or misdemeanors; and

WHEREAS, the Mayor and Board of Trustees find it to be in the best interests of the Village to amend the provisions of Section 8-1-2 to increase the penalties for petty offenses and misdemeanors in order to be consistent with the state penalty provisions for such offenses.

NOW, THEREFORE, BE IT ORDAINED BY THE MAYOR AND BOARD OF TRUSTEES OF THE VILLAGE OF CAROL STREAM, DUPAGE COUNTY, ILLINOIS, IN THE EXERCISE OF ITS HOME RULE POWERS, as follows:

SECTION 1: Section 8-1-2, "Penalties and Related Provisions, of the Carol Stream Code of Ordinances is hereby amended, and as amended shall read as follows:

8-1-2 PENALTIES AND RELATED PROVISIONS

(A) A violation of any provision of this Title, unless otherwise specified, or of an offenses classified as "petty" offenses under the aforesaid provisions of the Illinois Vehicle Code shall be punishable by a fine of not less than \$60 nor more than \$1,000 for each offense. Offenses classified as business offenses under the provisions of the Illinois Vehicle Code adopted by reference pursuant to this chapter, shall be punishable as set forth herein.

(B) Offenses classified as "Misdemeanors" under the provisions of the Illinois Vehicle Code, adopted by reference pursuant to this chapter, shall be subject to a fine/or imprisonment for a determinat term according to the following limitations.

(C) For a Class A Misdemeanor, imprisonment for any term less than one year and/or a fine of not less than \$1,000 and not to exceed \$2,500, except as provided in subsection 2.4 herein.

(D) For a Class B Misdemeanor, imprisonment for not more than 6 months and/or a fine of not less than \$300 and not to exceed \$1,500.

(E) For a Class C Misdemeanor imprisonment for not more than 30 days and/or a fine of not less than \$150 and not to exceed \$1,500.00.

(F) The Court, upon making a finding of guilty for any offense under Section 8-1-11-501 or 8-1-11-503 of this code, in addition to any sentence alternative elected by the Court, shall impose a fine of not less than \$2,000 if the defendant has previously been convicted of driving under the influence of alcohol or any prohibited controlled substance under any local code or under Section 11-503 of the Illinois Vehicle Code, or a similar provision under local ordinance.

(G) The Court, upon making a finding of guilty of any offense under Section 8-1-11-501 of this code, in addition to any sentencing alternative elected by the court, shall impose an additional fine of \$500 if the defendant had a breath alcohol content of .160 or higher in the case for which he or she is being sentenced.

(H) In addition to any other alternative sentence imposed by the Court, an individual found guilty of a violation of Section 8-1-11-501, whose operation of a motor vehicle while in violation of Section 8-1-11-501, proximately caused an incident resulting in an appropriate emergency response, shall be required to make restitution to a public agency for the costs of that emergency response. The restitution may not exceed \$1,000 per public agency for each emergency response. As used in this subsection (H), "emergency response" means any incident requiring a response by a police officer, a firefighter carried on the rolls of a regularly constituted fire department, or an ambulance.

(I) All fines recited herein are in addition to all costs, including DUI Tech Fees mandated by state statute which is adopted herein by reference.

(J) The Court, upon making a finding of guilty for any offense under Section 8-1-11-501 (a)(3), 8-1-11-501 (a)(4), 8-1-11-501(a)(5) or 8-1-11-501(6) of this code, in addition to any sentence alternative elected by the Court, shall impose a fee in the amount of \$50 for costs incurred by the Village for equipment and the handling of drug samples.

SECTION 2: This Ordinance amending Section 8-1-2 of the Code of Ordinances shall be reprinted in loose leaf volume that bears that title.

SECTION 3: This Ordinance shall be in full force and effect from and after its passage and approval by law.

PASSED AND APPROVED THIS ____ DAY OF _____, 2011.

AYES:

NAYS:

ABSENT:

Frank Saverino, Sr., Mayor

Beth Melody, Village Clerk

Village of Carol Stream
Interdepartmental Memo

TO: Joseph Breinig, Village Manager

FROM: James T. Knudsen, Director of Engineering Services 

DATE: December 13, 2011

RE: Klein Creek Flood Plain Structure Buyout Project – Resolution for Meeting the National Objective Under the Community Development Block (CDBG) Program of a Community Need Having a Particular Emergency

On April 21, 2011 the Village submitted an application for disaster recovery funding under the CDBG Disaster Recovery “IKE” Property Buyout Program. This application was made to provide the remaining funding necessary for the fourth buyout in our Klein Creek Flood Plain Structure Buyout Project. These homes were being purchased and then demolished thereby forever removing them from potential flood damage.

Because this is a CDBG application it must comply with the U.S. Housing and Community Development Act of 1974 (HCD Act). The HCD Act required CDBGs to meet at least one of three national objectives:

- Benefit low to moderate income persons; or
- Aid in the prevention or elimination of slums and blight; or
- Meet other community development needs that pose a serious and immediate threat to the health and welfare of the community.

When the Village prepared its application to the Illinois Department of Commerce and Equal Opportunity (DCEO) we were told the only national objective criteria we would meet is for benefiting low to moderate income people. Furthermore we were told we only had to submit the income information from just the property owners. Our application was submitted per instructions from DCEO.

On September 12, 2011 we received a letter from DCEO stating the “Carol Stream project has been approved in the amount of \$252,880 under Illinois Community Development Block Grant-Disaster Recovery “IKE” Program (CDBG “IKE” Program)”. On October 19th we received another letter (unsigned) from DCEO stating our “project will be awarded a grant”. In order to complete the grant agreement the Village had to have three documents resigned by the Mayor and Village Clerk and income documentation had to be provided for each of the four homes. The resigned documents were provided and since our application was for a single house only their income information had to be provided which

it was in the original application. Because they based the grant award on all four homes the amount was reduced from \$252,880 to \$91,463. This was confirmed in a letter received from DCEO on December 1st.

I was recently informed by a consultant that performs audits and compliance monitoring for FEMA and DCEO that our application did not meet the national objective for benefiting low to moderate income persons and the grant could not be approved. According to the consultant the entire household income had to be considered not just the property owner's income. Including this additional income would not qualify as low to moderate income. However, the consultant did say the project would qualify for "urgent need" and all the Village had to do was pass a resolution of urgent need and submit all the household income to DCEO. The income information was submitted directly to the consultant on December 9th.

The property owners have stated they can't make repairs to their home since the last flood had damaged their home. Also they are in constant fear of additional damage and for their safety and health as they are an elderly couple. The Village does not have funds dedicated for this project in the time frame required and has exhausted all other sources of grant funding from the Federal Emergency Management Agency (FEMA) and DuPage County. Therefore, staff recommends the Village approve this resolution of urgent need where it has been determined there is a serious and immediate threat to the health, safety and welfare in the community which was created by the flooding disasters of 2008 and 2010 and the Village is unable to finance this project on its own and no other sources of funding are available to fund the project in the time frame required.

Cc: Jon Batek, Finance Director
William N. Cleveland, Assistant Village Engineer

RESOLUTION NO. _____

**A RESOLUTION FOR MEETING THE NATIONAL OBJECTIVE UNDER THE
COMMUNITY DEVELOPMENT BLOCK GRANT (CDBG) PROGRAM OF A
COMMUNITY DEVELOPMENT NEED HAVING A PARTICULAR URGENCY**

WHEREAS, the Village of Carol Stream, Illinois, is applying to the State of Illinois for a CDBG Disaster Recovery Public Infrastructure grant; and

WHEREAS, for a project to be eligible for funding it must meet one of the national objectives under the CDBG Program; and

WHEREAS, it has been determined that a serious and immediate threat to the health, safety, or welfare of the community exists; and

WHEREAS, the threat was created by the flooding disasters of 2008 and 2010 and so is considered to be of recent origin; and

WHEREAS, the Village is unable to finance the activity on its own; and

WHEREAS; no other sources of funding are available to carry out the activity in the time frame required; and

NOW, THEREFORE, BE IT RESOLVED BY THE MAYOR AND BOARD OF TRUSTEES OF THE VILLAGE OF CAROL STREAM, DU PAGE COUNTY, ILLINOIS, IN THE EXERCISE OF ITS HOME RULE POWERS, as follows:

SECTION 1: That the Village does hereby confirm that the Klein Creek Flood Plain Structure Buyout Project in the application for CDBG disaster recovery funding under the CDBG Disaster Recovery "IKE" Property Buyout Program meets the national objective under the CDBG Program of meeting a community development need having a particular urgency.

SECTION 2: That the Mayor and Village Clerk on behalf of the Village execute such documents and all other documents necessary for the carrying out of said application.

SECTION 3: That this Resolution shall be in full force and effect from and after its passage, as provided by law.

PASSED this 19th day of December, 2011.

AYES:

NAYS:

ABSENT:

ATTEST:

Frank Saverino, Sr., Mayor

Beth Melody, Village Clerk

AGENDA ITEM

RESOLUTION NO. _____

I-2 12-19-11

A RESOLUTION DECLARING SURPLUS PROPERTY OWNED BY THE VILLAGE OF CAROL STREAM

WHEREAS, in the opinion of the corporate authorities of the Village of Carol Stream, Illinois, it is no longer necessary or useful, or for the best interests of the Village of Carol Stream to retain ownership of the personal property described in "Exhibit A"; and

WHEREAS, the described personal property has been determined by the corporate authorities of the Village of Carol Stream to have negligible value to the Village; and

WHEREAS, it has been determined by the Mayor and Board of Trustees of the Village of Carol Stream to dispose of the surplus property.

NOW, THEREFORE, BE IT RESOLVED BY THE MAYOR AND BOARD OF TRUSTEES OF THE VILLAGE OF CAROL STREAM, DUPAGE COUNTY, ILLINOIS, IN THE EXERCISE OF ITS HOME RULE POWERS, as follows:

SECTION 1: That the Mayor and Board of Trustees of the Village of Carol Stream find that the personal property described in Exhibit "A", now owned by the Village of Carol Stream, is no longer useful and authorize its disposal per the attached memorandum dated December 9, 2011.

SECTION 2: This resolution shall be in full force and effect from and after its passage and approval in the manner provided by law.

PASSED AND APPROVED THIS 19th DAY OF DECEMBER, 2011.

AYES:

NAYS:

ABSENT:

Frank Saverino, Sr., Mayor

ATTEST:

Beth Melody, Village Clerk

EXHIBIT "A"

Village of Carol Stream
Interdepartmental Memo

TO: Joseph Breinig, Village Manager
FROM: Philip J. Modaff, Director of Public Works
DATE: December 9, 2011
RE: Surplus Equipment for Sale or Scrap

The Department has identified several items to be declared surplus:

Two-way radios (11)

- Kenwood Model# TK-701S Serial# 8060227
- Kenwood Model# TK-720 Serial# 30400264
- Kenwood Model# TK-730 Serial# 71100137
- Kenwood Model# TK-730 Serial# 60600028
- Kenwood Model# TK-720 Serial# 21100143
- Kenwood Model# TK-730 Serial# 50100136
- Kenwood Model# TK-720 Serial# 0100098
- Kenwood Model# TK-720 Serial# 1010266
- Kenwood Model# TK-701S Serial# 7060101
- Kenwood Model# TK-760H Serial# 11000485
- Motorola Model# D33JAA3000 Serial# 610FLC02667

Replacement of these radios occurred as part of the recent conversion to narrow-banding for two-way radio communication. Most of our current radios were able to be re-programmed, but these models were too old.

Ford Pick-up (#37) 1997 Model F250 VIN#1FTHF26G2VEC40759
Replacement of this item was budgeted in the current fiscal year and a new unit has been received and placed into service.

Ford Pick-up (#38) 1997 Model F250 VIN#1FTHF26G2VEC40758
Replacement of this item was budgeted in the current fiscal year and a new unit has been received and placed into service.

Pitney Bowes Copier Model C235 Serial# 0021615
This item was not budgeted for replacement but failed beyond repair.

I am recommending that these items be declared surplus by the Mayor and Board of Trustees and that I be authorized to sell or otherwise dispose of the items.

Village of Carol Stream

Interdepartmental Memo

TO: Joseph E. Breinig, Village Manager

FROM: Donald T. Bastian, Assistant Community Development Director

DB

THROUGH: Robert J. Glees, Community Development Director

AK

DATE: December 14, 2011

RE: Agenda Item for the Village Board Meeting of December 19, 2011: Request for Approval of a New Ground Sign at the College of DuPage Carol Stream Regional Center - 500 N. Kuhn Road

PURPOSE

The purpose of this memorandum is to coordinate a request for Village Board approval of a new ground sign at the College of DuPage Carol Stream Regional Center at 500 N. Kuhn Road.

DISCUSSION

The College of DuPage is in the process of updating the monument signs at several of its regional education centers to match the silver and green color scheme and signage design theme found at COD's main campus.

In 2001, the Village of Carol Stream and the College of DuPage authorized an Intergovernmental Agreement (IGA) in advance of the conversion of the former fire station building on Kuhn Road into COD's Carol Stream Regional Center, which opened in 2004. With respect to signage, the IGA states the following: "The Village agrees to waive its fees and applicable ordinances for mutually agreeable signage" (emphasis added). Since the IGA was approved by the Village Board, it is staff's interpretation that the Village Board must make the determination as to whether the proposed signage is agreeable to the Village. A photo of the existing sign (left) and a rendering of the proposed sign (right) are provided below.

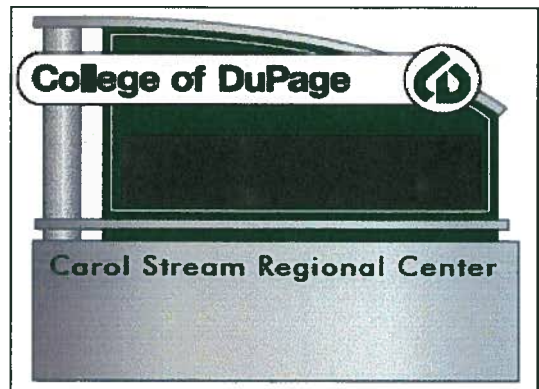

In review of the proposed sign, we note that the height and area of the proposed sign will be very similar to the existing sign. Carla Burkhart of Herricane Graphics, which is the sign contractor for the project, has stated that the new sign will be installed upon the existing footing and internal structural support system for the current sign. Ms. Burkhart has also stated that the LED changeable copy message board from the existing sign will be removed from the old sign and reinstalled within the new sign. Additional detail regarding the proposed sign is provided on the attached sheets.

Overall, staff finds the height, area and design of the proposed sign to be appropriate given the public educational use of the property. The existing sign is beginning to appear faded, and the new sign will have an updated and contemporary appearance that will help establish COD's architectural design theme at the Carol Stream Regional Center. Staff has no objection to the proposed replacement ground sign.

RECOMMENDATION

If the Village Board finds the proposed sign to be acceptable and wishes to authorize COD to proceed with the installation of the sign, the Board should pass the following motion:

Motion to approve the proposed replacement ground sign at the College of DuPage Carol Stream Regional Center at 500 N. Kuhn Road.

C: Dr. Robert L. Breuder, President, College of DuPage
Beverly Carlson, Supervisor, Carol Stream Regional Center
Carla Burkhart, Herricane Graphics

DTB:db



Existing Sign - South Elevation / Kuhn Road

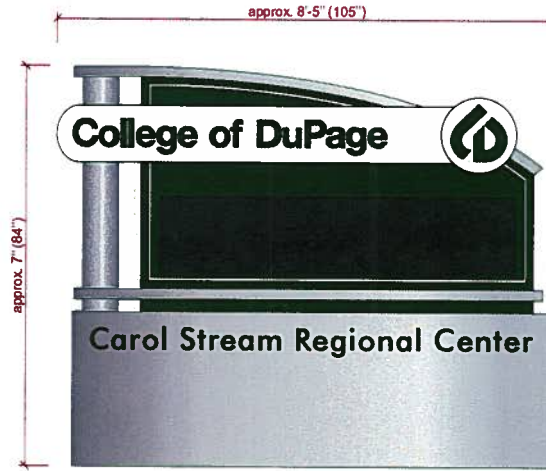

Proposed Dimensions - 61.25 square feet



Proposed Design - South Elevation / Kuhn Road

Client

College of DuPage
425 Fawell Boulevard
Glen Ellyn, IL 60137-6599

Title / Description

Offsite Facilities Rebrand

Scale N/A

Distribution # Date

Design - 03/14/2011

Location

Building: Carol Stream
Location: Kuhn Road

Last Edited By Date

Juergen Hacker 03/14/2011

Approval

Date / Signature

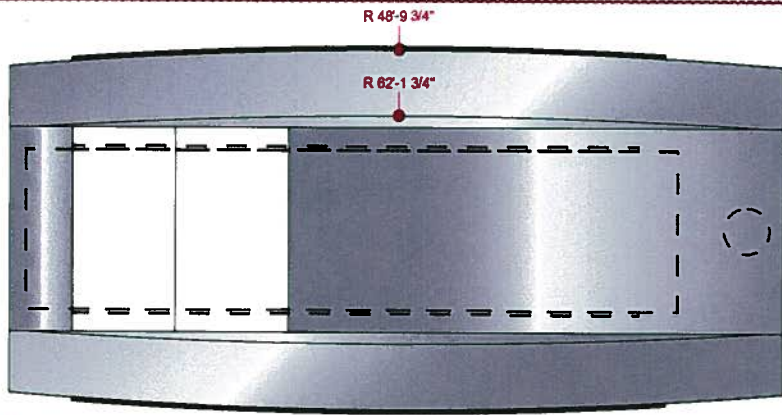

1. 125 Aluminum cabinet painted to match AKZO Nobel 325G5 (Metallic Green)
2. 125 Aluminum cabinet painted to match AKZO Nobel 354D3 (Metallic Green)
3. 4.5 PVC Tube painted to match AKZO Nobel 354D3 (Metallic Green)
4. 125 Aluminum horizontal detail to match AKZO Nobel 354D3 (Metallic Green)
5. 125 Aluminum Base painted AKZO Nobel 354D3 (Metallic Green).
6. 5" painted white reveal.
7. 5" cut aluminum plate characters printed all surfaces AKZO Nobel 325G5 (Metallic Green).
8. Existing Monochrome Watchfire LED units to be retrofitted into new cabinet.
9. 125 Translucent white acrylic with 1st surface 8500 series ORACAL 060 translucent dark green.
10. Internal illumination with GE Gelcore white LEDs.
11. 1" x .063 welded "L" molding painted white.

All signs to include photo cell based on either 120V or 480V power (include step-down transformers where required).

Sign contractor to verify the re-use of the existing footing at this location. Power here is 120 V (contractor to confirm).

** This sign type to match existing signs installed on main campus of COD Glen Ellyn, IL.

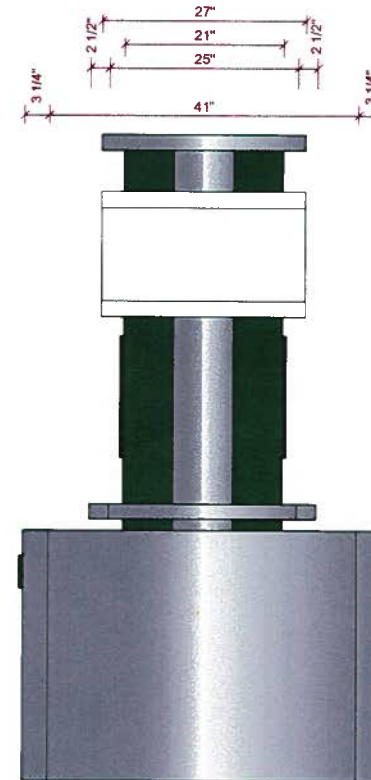
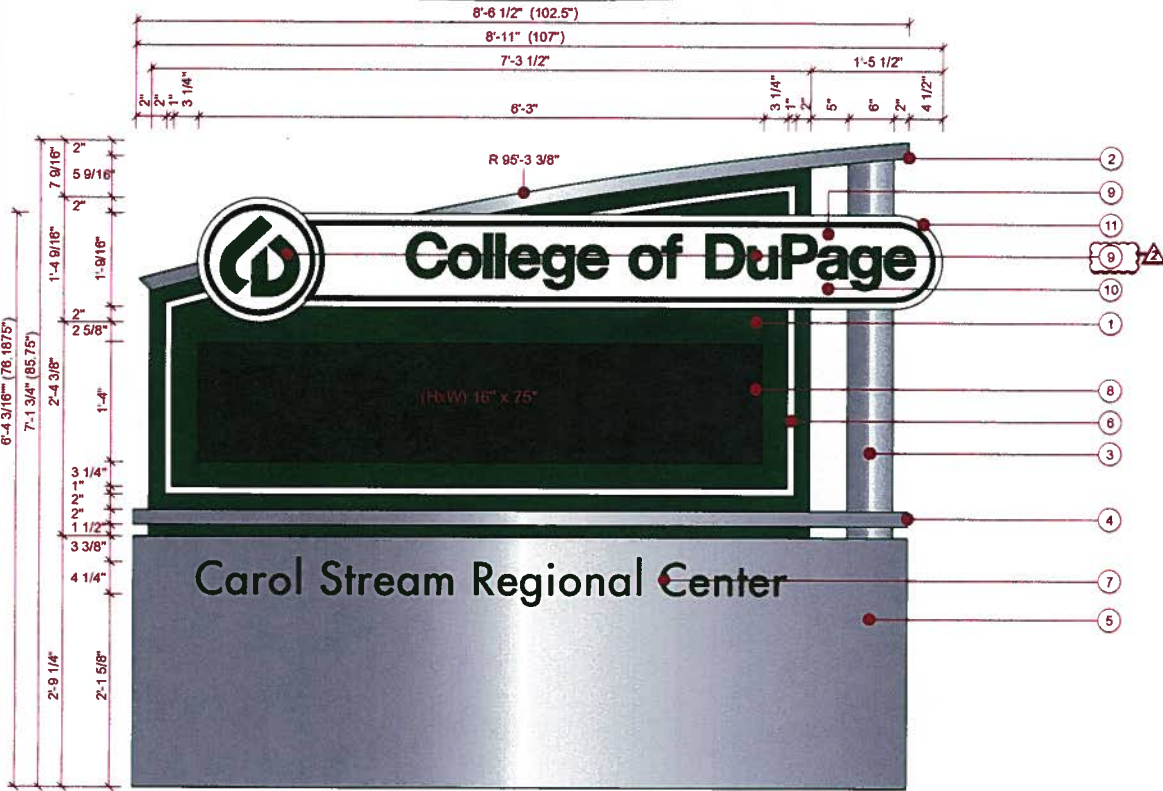

Client

College of DuPage
425 Fawell Boulevard
Glen Ellyn, IL 60137-6599

Title / Description

CRC Exterior Signage

Scale N/A

Distribution # Date

Design - 03/14/2011
RFP / Bid - 03/16/2011
Addendum A 03/28/2011
Addendum B 04/01/2011

Location

Building: Carol Stream
Location: Kuhn Road

Last Edited By Date

Juergen Hacker 03/14/2011
Juergen Hacker 03/16/2011
Juergen Hacker 03/28/2011
Juergen Hacker 04/01/2011

Approval

Date / Signature

© 2010/11 | Hurricane Graphics Inc.
1275 W. Roosevelt Rd., Ste 112
West Chicago, IL 60185
P 630.293.8030 | F 630.293.8031

Page 11 of 40

Sign Type S02.3 - 3/4" = 1' (63.72 / 54.23 square feet)

Village of Carol Stream
Interdepartmental Memo

DATE: December 15, 2011

TO: Mayor Saverino Sr. & the Village Board of Trustees
Joseph E. Breinig, Village Manager

FROM: Christopher Oakley, Asst. to the Village Manager *cmo*

RE: Request to Use Social Media to Promote 2012 Concerts & Town Center Events

Planning for the 2012 Summer Concert Series and other Town Center events is underway. A Summer Concert Series sponsorship mailing went out the 1st week of December detailing some of the bands under consideration as well as the inventory of sponsor benefits that accrue to a sponsoring company for their partnership and financial support of 2012 Town Center events. One of the benefits that past sponsors have inquired about is recognition and support on Village social media sites. To this end, I included sponsorship recognition via a future Village-initiated FACEBOOK page as a new benefit for the upcoming 2012 event season. This was done to continue the established tradition of crafting a sponsorship program that includes associated benefits that meet the needs of past, current and hopefully new event sponsors.

One of the goals approved by the Village Board and identified in the current budget document in the Management Services Section (pp. 134) states that staff will *'investigate the use of social media to better promote information on news, events, programs and services'*. Extensive research has been conducted on the use of social media by local governments and staff has gathered and reviewed various policies in place by local governments here and abroad (attachment 2 -Village of Schaumburg). A draft policy is currently under review by the Village Manager's Office with direction and feedback provided by the Executive Team. Associated issues regarding records storage and retention, freedom of information compliance as well as dedicated access to future Village accounts are being discussed that will assist in the development of a final draft for review by both Legal Counsel and the Village Board.

The Village currently has an inactive FACEBOOK that has been secured and is accessible at Village-of-Carol-Stream to communicate with the public to include residents and our various customers groups. Permission is sought to activate this account in early January to begin promoting 2012 Town Center events as well as recognizing our events sponsors for their pledged support of the upcoming event season. In utilizing a FACEBOOK account for this purpose, Village staff will ease into the social media realm and gain some confidence and experience for using this tool for expanded purposes such as emergency preparedness and response, public safety, roadway maintenance scheduling and the rerouting of local traffic and the likes.

Some of the content that the Village would likely post on an event FACEBOOK page would include but not be limited to the following:

- ♪ **Organizational Commitment to Arts Programming**
- ♪ **Names and Web Sites of Our Event Sponsors**
- ♪ **Names of Scheduled Entertainers & Links to the Band Web Site**
- ♪ **Featured Food Vendors & their Menu Items**
- ♪ **Door Prizes Raffled at Concerts**
- ♪ **Remote Parking Concerns & the Availability of Shuttle Service**
- ♪ **Charitable Events Such as the ‘Concert for the Troops’ and ‘Buds Run’**
- ♪ **Rescheduled Dates for Cancelled/Postponed Events**

Please include this matter as an agenda item for the upcoming Dec. 19th meeting for consideration and direction by the Village Board. I have attached several documents that support the effectiveness of using social media tools to successfully promote civic and cultural events.

(1) Twilight Concert Series

2 1

Concert Series



Twilight Concert Series

Like

Concert Venue Salt Lake City, Utah

Wall

Info

Friend Activity

Photos

Events

Wall

Twilight Concert Series · Everyone (Top Posts)

Share: Post Photo

Write something...

About

Line-up and Concert Information available at:
www.twilightconcertseries.com/

9,504

like this

5

talking about this

Likes



Living Traditions Festival



Salt Lake City Arts Council

Create a Page

Get Updates via RSS

Report Page

Share



Twilight Concert Series

Next summer will be our 25th Anniversary Season of the Twilight Concert Series. Over the past 24 years, which have been your favorite or most memorable Twilight Concerts?

Like Comment Share October 27 at 3:03pm

15 people like this.

View all 70 comments

Write a comment.



Fernando Carvajal

I was able to get a reply from u2 people it turns out it costs about \$3 Million to book them. I don't know if they would be free since its a free concert!

Like Comment November 17 at 3:37am



Twilight Concert Series

What was your favorite Twilight Concert this past summer?

Like Comment Share October 3 at 12:32pm

3 people like this.

View all 101 comments

Write a comment.



Twilight Concert Series added 22 new photos to the album August 25, 2011 · Lupe Fiasco and Big K.R.I.T. — at Twilight Concert Series @ Pioneer Park.

Using Social Media to Promote Events

by out-smarts on Tuesday, May 11, 2010 at 3:40pm

Social Media tools are great for building awareness of what you do, for reaching and connecting with new audiences, for building and maintaining your networks and for driving targeted traffic to your website. Social networks are communities of people that connect and communicate online based on something they have in common. It makes sense therefore that social media tools can help you to promote events such as seminars, networking opportunities, concerts and sales.

You can use social media to promote practically any event but doing so takes time and effort. Here are a few pointers to bear in mind that will increase the likelihood of your success in using these tools to sell out your event.

Target Your Audience

Don't try to submit your event to each and every event site out there, instead choose sites that are targeted to attract the desired audience. For example, if your event is in Vancouver and use Vancouver events site. If your event is a social one then post it on a "social" network like Facebook but if it is aimed at professionals, then LinkedIn will be a good tool to reach your target audience. If your event is aimed at the tech community then check out Techvibes but if its music oriented then Oscillations might be a better choice. The point here is that like any other marketing or promotional effort, online events promotion should be very specifically targeted to your intended audience.

High Ranking Events Sites

Only list on events sites with a page rank of 4 or higher. The higher the ranking the better from a search engine optimization perspective and the more likely your audience will be to actually find your event. A great multi purpose events site with a high ranking is MeetUp - with a page rank of 7. It is better to submit to a few sites that get tonnes of traffic than to submit to lots of sites that hardly get any visitors.

Submit Events Consistently

If you start using social media to promote events then you should be prepared to do so consistently. Choose 5 -10 highly targeted events sites with a high page rank and submit all of your events to these sites and do so regularly. You will begin to build a following in these forums and the last thing you want to do is to annoy them with intermittent and inconsistent listings.

Events promotion lends itself well to social media because the inherent nature of an event is social. If you follow the 3 tips above, not only will you drive more awareness of your events but you will also be able to tap into the nature of social communities. If people enjoy your events they will be more likely to suggest them to others in their online communities and so the buzz will build.

Village of Schaumburg

Village of Schaumburg

<http://www.facebook.com/#!/pages/Schaumburg-IL/Village-of-Schaumburg/58124652103?ref=ts>

Schaumburg Prairie Center for the Arts

<http://www.facebook.com/#!/pages/Schaumburg-IL/Prairie-Center-for-the-Arts/151265188218365?ref=ts>

Schaumburg Prairie Center Arts Foundation

<http://www.facebook.com/#!/pages/Prairie-Center-Arts-Foundation/107120586012298?ref=ts>

Twitter:

A follower cannot put a post directly on our twitter page, but they can retweet what we said -- to other people, and add their own comment.

They can 'mention us' on their own profile.

They could do this anyway, just by saying our name.

Why do we like Twitter (b/c it's free)

Facebook:

When did the FB page launch (April 2009)

Users can not write on our Wall

Where do we get our material (from our website)

Why do we like FB (b/c it's free)



VILLAGE OF SCHAUMBURG

MUNICIPAL CENTER / 101 SCHAUMBURG COURT / SCHAUMBURG, IL 60193-1899
847.895.4500 / TDD 847.923.4435 / FAX 847.895.7806 / WWW.CI.SCHAUMBURG.IL.US

Number: #061-2010
Effective Date: 1/11/10
Title: Use of Social Media for Village Communications
Category: Community Communication
Originating Department: VMO
This is a: New Administrative Protocol

Section 1: Purpose. To address the fast-changing landscape of the Internet and the way residents, businesses, and visitors (stakeholders) communicate and obtain information from the village online.

Section 2: Definition. Social media is any website or medium (including video) that allows for interactive communication in the open with Internet users. Examples of social media include Facebook and Twitter (social networking), YouTube (video sharing), and Flickr (online photo management and sharing). These social media networks provide two-way communication with stakeholders, as opposed to a website, which only offers one-way/outgoing communication.

Section 3: General. With social media becoming a relevant resource for local government to communicate with its stakeholders, the village has developed this administrative protocol to incorporate the use of these applications. This protocol also supplements the personnel manual regarding employee responsibilities for Internet usage.

The village will not utilize its selected social networks as a chat tool. Only pre-approved materials are to be posted. Designated social media users are only to 'reply' to comments made by others if the 'reply' has been approved. For instance, if someone outside the village commented that they will use the Family Counseling Center, a comment of clarification may be communicated that only residents are eligible for this service.

Section 4: Procedure. The village encourages the use of social media to further its goals and the missions of its departments where appropriate. Social media will also assist the village to deliver its core services.

- A. All official village presences on social media sites or services are considered an extension of the village's information networks.
- B. The village manager, through a social media administrator, will approve what social media outlets are suitable for use by the village.
- C. Of those social media sites selected for use, the village will use a single account that is branded with the village logo. Additional accounts may be considered after review by the social media administrator and approval by the village manager.

- D. The social media administrator will monitor social media use and must review and approve all content prior to posting. Content will be reviewed for appropriateness, quality, consistency with overall village message and branding, priority, goals, etc.
 - 1. Departmental specific content review and approval may be delegated to that department, which will allow that department to work independently from the village social media accounts.
 - a. Those departmental approvers/content providers must have that department director's approval before being considered by the village social media administrator for delegation of this responsibility to that department.
 - b. Departmental social media administrators must be in compliance with this protocol and may not establish more liberal procedures or practices without the review of the village social media administrator and approval of the village manager.
 - c. Departmental social media administrators must provide a monthly update as to its social media usage. This is to be reported within the department's monthly report document.
- E. Employees granted permission to use these outlets are responsible for complying with applicable federal, state, and county laws, regulations, and policies. This includes adherence to established laws and policies regarding copyright or plagiarism, records retention, Freedom of Information Act/FOIA, First Amendment, privacy and information security policies and protocols established by the village.
- F. Wherever possible, links to more information should direct users back to the village's official website for more information, forms, documents, or online services necessary to conduct business with the village.
- G. Employees representing the village via social media outlets must conduct themselves at all times as representatives of the Village of Schaumburg.
- H. Employees who fail to conduct themselves in professional manner, and/or are found in noncompliance with any personnel manual policies, administrative protocols, and department rules and regulations, will be subject to the corrective action procedures found in the personnel manual. Violation of this protocol may result in the removal of department pages from social media outlets.

AGENDA ITEM

J-3 12-19-11

Village of Carol Stream Interdepartmental Memo

TO: Joseph E. Breinig, Village Manager

FROM: Jamie Grant, Administration Secretary *JG*

DATE: December 15, 2011

RE: 2012 Raffle License Application - American Legion Post 76

The annual raffle license for American Legion Post 76 expires December 31, 2011. The Legion has advised their 2012 Raffle License Application will be submitted on Monday, December 19th and therefore is not included in the agenda packet. It will be on file in the Clerk's office when received.

The American Legion is a not-for-profit organization with proceeds from the raffles donated to various local charities, scouts and ball teams, which benefit the residents of the Village of Carol Stream.

Please place this on the agenda for Monday, December 19, 2011 for the Board's approval of the raffle license to the American Legion Post 76. Approval is subject to receiving all required documentation in a satisfactory format by December 31, 2011. No waiver of fee or manager fidelity bond is being requested.

Please let me know if any additional information is necessary. Thank you.

jpg

Village of Carol Stream
 Schedule of Bills
 For Village Board Approval on December 19 2011

AGENDA ITEM
K-1 12-19-11

<u>Vendor / Description</u>	<u>Amount</u>	<u>Account Number</u>	<u>Account Description</u>	<u>Invoice No.</u>	<u>Purchase Order</u>
1ST AYD CORPORATION					
RUST PEN/WIPERS	195.99	04201600-53317	OPERATING SUPPLIES	505023	
	<u>195.99</u>				
A TO Z ALL PURPOSE RENTAL INC					
TENT STRG NOV/11	150.00	01680000-52244	MAINTENANCE & REPAIR	16103	
	<u>150.00</u>				
ACCURATE OFFICE SUPPLY CO					
LABELS	21.04	01662600-53314	OFFICE SUPPLIES	183987	
	<u>21.04</u>				
AFTERMATH INC					
EVID CABINET SANITIZE	95.00	01662400-53317	OPERATING SUPPLIES	JC2011-0083	
EVIDENCE CAB CLEANING	95.00	01662400-53317	OPERATING SUPPLIES	JC20110025	
	<u>190.00</u>				
AIR SCIENCE USA					
FILTERS FOR DRY BIN	381.40	01662400-53317	OPERATING SUPPLIES	15302	
	<u>381.40</u>				
ALANIZ LAWCARE INC					
MOWING NORTH AV, SCHMALE,ARMY TRL OCT/11	3,451.52	01670400-52272	PROPERTY MAINTENANCE	4414	
	<u>3,451.52</u>				
AMERICAN FIRST AID					
1ST AID SUPPLIES	14.53	01670100-53317	OPERATING SUPPLIES	112484	
RE-STOCK SUPPLIES	89.61	01650100-53317	OPERATING SUPPLIES	112454	
	<u>104.14</u>				
AMERICAN INFRASTRUCTURE TECHNOLOGIES LLC					
SCADA UPGRADE INSTALLATION	7,500.00	04101500-54480	CONSTRUCTION	2011-21-03	20120045
	<u>7,500.00</u>				
AMERICAN MESSAGING					
SERV FOR NOV/11	4.44	01662600-52243	PAGING	U1113407LK	
SERV FOR NOV/11	4.45	01690100-52264	EQUIPMENT RENTAL	U1113407LK	
SERV FOR NOV/11	4.45	04201600-52243	PAGING	U1113407LK	

SERV FOR NOV/11	13.33	01662500-52243	PAGING	U1113407LK	
SERV FOR NOV/11	19.44	01660100-52243	PAGING	U1113407LK	
SERV FOR NOV/11	35.80	01670100-52243	PAGING	U1113407LK	
	<u>81.91</u>				
AMERICAN PUBLIC WORKS ASSOCIATION					
REFUND-REGIS MODAFF	-230.00	04200100-52234	DUES & SUBSCRIPTIONS	10/27/11	
	<u>-230.00</u>				
AMERICAN SOCIETY OF CIVIL ENGINEERS					
NAT'L/IL DUES KNUDSEN	240.00	01620100-52234	DUES & SUBSCRIPTIONS	104/544657	
	<u>240.00</u>				
ANDY FRAIN SERVICES					
CROSSING GUARD SERV'S NOV/2011	10,207.95	01662300-52105	CROSSING GUARDS	155887	
	<u>10,207.95</u>				
AVALON PETROLEUM COMPANY					
REGULAR GASOLINE	20,925.00	01696200-53356	GAS PURCHASED	547637	20120089
	<u>20,925.00</u>				
B & F TECHNICAL CODE					
BUILDING PLAN REV's 285 e FULLERTON	895.50	01643700-52253	CONSULTANT	34174	20120007
PLUMBING INSPECTIONS SERV'S-NOV/2011	1,059.20	01643700-52253	CONSULTANT	34122	20120008
	<u>1,954.70</u>				
BARN OWL FEED & GARDEN CENTER					
GRASS SEED	99.50	04201600-53317	OPERATING SUPPLIES	115809	
LAWN REPAIR SUPPLY	94.26	01670700-53317	OPERATING SUPPLIES	116579	
	<u>193.76</u>				
BATTERIES PLUS					
BATTERIES	381.60	01670100-53317	OPERATING SUPPLIES	487210714	
	<u>381.60</u>				
BATTERY SERVICE CORPORATION					
12V BATTERY	76.50	01696200-53354	PARTS PURCHASED	316238	
	<u>76.50</u>				
BEACON SSI INC					
GAS TANK REPAIRS	2,192.74	01696200-52244	MAINTENANCE & REPAIR	67531	
	<u>2,192.74</u>				
BHFX DIGITAL IMAGING					
1055 CM PLOTTER PAPER	329.18	01620100-53317	OPERATING SUPPLIES	063510	
	<u>329.18</u>				
BITTNER'S SPRAY EQUIPMENT					

GENERIC SILVER PLUS	125.00	01670400-53317	OPERATING SUPPLIES	59922
	125.00			
BRACING SYSTEMS				
CONCRETE SUPPLIES	168.75	01670500-53317	OPERATING SUPPLIES	1788461
CONCRETE SUPPLIES	709.00	01670500-53317	OPERATING SUPPLIES	1778251
PAINT	46.68	01621300-53317	OPERATING SUPPLIES	178610-1
SUPPLIES	414.95	01670500-53317	OPERATING SUPPLIES	1804671
	1,339.38			
C A S OF NEW ENGLAND INC				
CABLE	96.10	01696200-53316	TOOLS	408453519
	96.10			
CALL ONE				
SERV FRM NOV 15 THRU DEC 14 2011	415.04	04101500-52230	TELEPHONE	DEC 15 2011
SERV FRM NOV 15 THRU DEC 14 2011	2,403.75	04201600-52230	TELEPHONE	DEC 15 2011
SERV FRM NOV 15 THRU DEC 14 2011	2,835.75	01650100-52230	TELEPHONE	DEC 15 2011
	5,654.54			
CARHARTT INC				
OVERALLS	125.13	04201600-53324	UNIFORMS	1100353170
	125.13			
CAROL STREAM LAWN & POWER				
LAWN MIX	14.00	04201600-53317	OPERATING SUPPLIES	290919
PARTS	4.06	01670700-53317	OPERATING SUPPLIES	289575
REFUND-TUBE ASSEMBLY	-107.69	01670500-53317	OPERATING SUPPLIES	289193
	-89.63			
CARQUEST AUTO PARTS				
AIR FILTER	30.54	01696200-53354	PARTS PURCHASED	2420221538
AIR FILTER	58.77	01696200-53354	PARTS PURCHASED	2420-220056
BRAKE PARTS	-65.78	01696200-53354	PARTS PURCHASED	2420222008
BRAKE PARTS	112.50	01696200-53354	PARTS PURCHASED	2420222178
BRAKE PARTS	409.99	01696200-53354	PARTS PURCHASED	2420221840
FUEL/AIR FILTERS	81.18	01696200-53354	PARTS PURCHASED	2420220609
HYD FITTING	7.62	01696200-53354	PARTS PURCHASED	2420221859
INFLATOR/GAUGE	48.99	01696200-53317	OPERATING SUPPLIES	2420220867
OIL FILTER	33.92	01696200-53354	PARTS PURCHASED	2420221254
OIL FILTERS	31.36	01696200-53354	PARTS PURCHASED	2420221511
PART-BUSHING	1.92	01696200-53354	PARTS PURCHASED	2420-220007
PART-FILTER	14.06	01696200-53354	PARTS PURCHASED	2420-220151
PART-HEX DRIVER	14.72	01696200-53354	PARTS PURCHASED	2420222585
PART-WIPERS	41.75	01696200-53354	PARTS PURCHASED	2420221959
PARTS-FUSE	11.46	01696200-53354	PARTS PURCHASED	2420-219980

PARTS-OIL FILTERS	23.52
PARTS-OIL/AIR FILTERS	72.31
PARTS-OIL/FUEL FILTERS	315.76
PARTS-WIPERS	37.24
RETURN DRIVER	-14.72
RUNNING BOARDS	216.92
SPARK PLUGS	50.00

1,534.03

CARSON PIRIE SCOTT

CLOTH ALLOW - GREY	36.99
--------------------	-------

36.99

CARYL REBHOLZ

TRANSPORTATION TO CONF 10/23-26	155.40
---------------------------------	--------

155.40

CDW GOVERNMENT INC

TERMINAL FOR SGTs	415.45
-------------------	--------

415.45

CHEM CARE INC

TP & PAPER PRODUCTS	340.00
---------------------	--------

340.00

CHICAGO INTERNATIONAL TRUCK LLC

PART - HOSE	46.24
PART - HOSE	92.48
PART-HOSE	46.24
PARTS - GEAR 11/2/11	1,220.71
PARTS-PAN/GASKET/BOLT	605.98

2,011.65

CHICAGO PARTS AND SOUND

BRAKE PARTS	230.94
BRAKE PARTS	340.88
CYLINDERS OCT/11	29.45
MATRIX ASSY & PAD RF	-78.98
PART-RESISTOR	19.14
PART-WIPER	126.01
PARTS-ALTERNATOR ASY	433.24
PARTS-BRAKES	335.38
PARTS-PUMP ASY	75.56
ROTOR/PADS	219.92

1,731.54

01696200-53354	PARTS PURCHASED	2420223112
01696200-53354	PARTS PURCHASED	2420221640
01696200-53354	PARTS PURCHASED	2420-220157
01696200-53354	PARTS PURCHASED	2420-220130
01696200-53354	PARTS PURCHASED	2420223040
01696200-53354	PARTS PURCHASED	2420222189
01696200-53354	PARTS PURCHASED	2420221836

01664700-53324	UNIFORMS	535339495
----------------	----------	-----------

01600000-52223	TRAINING	REIMB IPELRA
----------------	----------	--------------

01652800-54412	OTHER EQUIPMENT	B351581
----------------	-----------------	---------

01670100-53317	OPERATING SUPPLIES	30037
----------------	--------------------	-------

01696200-53354	PARTS PURCHASED	16023843
01696200-53354	PARTS PURCHASED	16024757
01696200-53354	PARTS PURCHASED	16023560
01696200-53354	PARTS PURCHASED	16023628
01696200-53354	PARTS PURCHASED	16024339

01696200-53354	PARTS PURCHASED	425193
01696200-53354	PARTS PURCHASED	422367
01696200-52264	EQUIPMENT RENTAL	908256
01696200-53354	PARTS PURCHASED	424033
01696200-53354	PARTS PURCHASED	422053
01696200-53354	PARTS PURCHASED	423467
01696200-53354	PARTS PURCHASED	424622
01696200-53354	PARTS PURCHASED	420858
01696200-53354	PARTS PURCHASED	424333
01696200-53354	PARTS PURCHASED	423709

CHOICE OFFICE EQUIPMENT AND SUPPLIES INC

SUPPLIES FOR COPIER	5.82	04100100-52231	COPY EXPENSE	20110991
	<u>5.82</u>			

CIOSEK TREE SERVICE INC

EMERGENCY TREE WORK	33,170.00	01670700-52268	TREE MAINTENANCE	JUL28 -AUG4 EMRG
	<u>33,170.00</u>			

COMED

SERV FRM 10/19 - 11/16	873.92	04201600-52248	ELECTRICITY	0300009027NOV/11
SERV FRM 10/21 - 11/21	19.74	06320000-52248	ELECTRICITY	1603109101NOV/11
SERV FRM 10/21 - 11/21	78.32	04101500-52248	ELECTRICITY	0291093117NOV/11
SERV FRM 10/24 - 11/22	97.73	01670600-52248	ELECTRICITY	5838596003NOV/11
SERV FRM 10/20 THRU 11/18	44.31	06320000-52248	ELECTRICITY	1043062112NOV/11
SERV FRM 10/25 - 11/23	25.70	01670600-52248	ELECTRICITY	2127117053NOV/11
SERV FRM 10/25 - 11/23	198.73	06320000-52248	ELECTRICITY	0815164035NOV/11
	<u>1,338.45</u>			

CONCEPT WIRELESS COMMUNICATIONS INC

TWO WAY RADIO EQUIPMENT PRGM	668.40	04200100-54417	RADIOS	153060	20120063
TWO WAY RADIO EQUIPMENT PRGM	669.00	01670100-54417	RADIOS	153060	20120063
TWO WAY RADIO EQUIPMENT PRGM	1,948.00	04201600-54417	RADIOS	153060	20120063
TWO WAY RADIO EQUIPMENT PRGM	4,000.00	01670400-54417	RADIOS	153060	20120063
	<u>7,285.40</u>				

CONSULTING AUDIOLOGICAL ASSOCIATES INC

HEARING RETREAT 11/9/11	150.00	01690100-52223	TRAINING	14766
	<u>150.00</u>			

COSMOS DESIGN DIRECT

CLOTH ALLOW - JONES	488.00	01662400-53324	UNIFORMS	78433
	<u>488.00</u>			

DAILY HERALD

NON-COMPLIANCE NOTICE	28.75	04101200-52240	PUBLIC NOTICES/INFORMATION	T4281397
TIF N/S PUBLIC NOTICE	1,288.00	01650100-57499	CONTINGENCY	T4280703
	<u>1,316.75</u>			

DAVID G BAKER

VLG BOARD MTG TELECAST 12/05/11	105.00	01650100-52253	CONSULTANT	120511
	<u>105.00</u>			

DELUXE TOWING

DUMP TRUCK TOW	150.00	01696200-53353	OUTSOURCING SERVICES	73946
TOW FEES 10/13/11	20.00	01662300-52212	AUTO MAINTENANCE & REPAIR	74245
TOW FEES 10/7/11	20.00	01662300-52212	AUTO MAINTENANCE & REPAIR	74098

TOW FEES 8/17/11	20.00	01662300-52212	AUTO MAINTENANCE & REPAIR	73720
TOW FEES 8/21/11	20.00	01662300-52212	AUTO MAINTENANCE & REPAIR	73703
TOW FEES 8/25/11	20.00	01662300-52212	AUTO MAINTENANCE & REPAIR	73852
TOW FEES 8/8/11	20.00	01662300-52212	AUTO MAINTENANCE & REPAIR	73628
TOW FEES 9/12/11	20.00	01662300-52212	AUTO MAINTENANCE & REPAIR	73935
TOW FEES 9/29/11	20.00	01662300-52212	AUTO MAINTENANCE & REPAIR	74150
TOW FEES-6/27/11	20.00	01662300-52212	AUTO MAINTENANCE & REPAIR	72988
TOW FEES-6/29/11	20.00	01662300-52212	AUTO MAINTENANCE & REPAIR	73319
TOW FEES-6/30/11	20.00	01662300-52212	AUTO MAINTENANCE & REPAIR	73285
TOW FEES-7/29/11	20.00	01662300-52212	AUTO MAINTENANCE & REPAIR	67823
TOW FEES-8/4/11	20.00	01662300-52212	AUTO MAINTENANCE & REPAIR	73600
	410.00			
DISCOVERY BENEFITS				
FLEXIBLE SPEINDING ADM DEC/2011	230.00	01600000-52273	EMPLOYEE SERVICES	280769
	230.00			
DITCH WITCH				
PAINT	42.00	01621300-53317	OPERATING SUPPLIES	C07362
	42.00			
DUPAGE CELLULAR COMM				
OIC CAR CHARGER	23.99	01662700-53317	OPERATING SUPPLIES	10052478
	23.99			
DUPAGE CO JUDICIAL CENTER				
ZEBRA PRINTERS	1,909.32	01662700-53350	SMALL EQUIPMENT EXPENSE	CCTCS1-2011
	1,909.32			
DUPAGE COUNTY				
DATA PROCESSING POLICE DEPT OCT/2011	250.00	01662600-52247	DATA PROCESSING	0153
	250.00			
EBAY INC				
EBAY SALES OCT 2011	465.00	01664700-53317	OPERATING SUPPLIES	OCT 2011
	465.00			
ETRAILER.COM				
TRAILER HITCH REC	69.71	01696200-53317	OPERATING SUPPLIES	101519578
	69.71			
EXELON ENERGY INC				
SERV FRM 10/19 - 11/17	1,964.04	04201600-52248	ELECTRICITY	100431200250
SERV FRM 10/19 11/16	1,990.87	06320000-52248	ELECTRICITY	200214600170
	3,954.91			
FACTORY CARD OUTLET				

SUPPLIES	18.26	01660100-53314	OFFICE SUPPLIES	95
	<u>18.26</u>			
FLEETPRIDE				
PART - VALVE	83.73	01696200-53354	PARTS PURCHASED	44686376
PART - VALVE	122.23	01696200-53354	PARTS PURCHASED	44696006
RETURN/CREDIT VALVE	-83.73	01696200-53354	PARTS PURCHASED	44750473
	<u>122.23</u>			
FLOOD BROTHERS DISPOSAL				
YARD WASTE STICKER 11/4/11	1,000.00	01-14120	YARD WASTE STICKERS	2433339
	<u>1,000.00</u>			
FOURTH DIMENSION INSTRUMENTS				
HOUR METERS FOR CHARGER CT L/S	79.74	04201600-53317	OPERATING SUPPLIES	12568
	<u>79.74</u>			
FRANKLIN COVEY CO				
DAILY PLANNER	34.63	01640100-53314	OFFICE SUPPLIES	133267184
	<u>34.63</u>			
GEXPRO				
150 HPS FIXTURES	2,301.72	01670300-52271	STREET LIGHT MAINTENANCE	265327185
	<u>2,301.72</u>			
GORDON FLESCH COMPANY INC				
EQUPT MTC 9/28-10/28	137.90	01662600-52226	OFFICE EQUIPMENT MAINTENANCE 1DD151 1	
	<u>137.90</u>			
GRAPHIC III PAPER				
NCR PAPER	465.90	01662700-53317	OPERATING SUPPLIES	397484
	<u>465.90</u>			
HAKOMI EDUCATIONAL RESOURCES				
M THOMAS TRNG CREDIT	-135.00	01662500-52223	TRAINING	MBT102911CR
	<u>-135.00</u>			
HAROLD W ROWE				
REPR & REBUILD BOOSTER PMP#4 EASTSIDE STN	1,671.23	04201600-52244	MAINTENANCE & REPAIR	1009
	<u>1,671.23</u>			
HD SUPPLY WATERWORKS				
HY SAFETY KIT/STEM	305.11	04201600-53317	OPERATING SUPPLIES	3921351
MATERIAL FOR REPAIRS	295.39	01670600-53317	OPERATING SUPPLIES	3842673A
	<u>600.50</u>			
HEALY ASPHALT COMPANY LLC				
CONCRETE	913.92	01670500-52286	PAVEMENT RESTORATION	31391MB

	<u>913.92</u>			
HENNESSY INDUSTRIES INC				
TIRE CHNGR CREDIT	-2,854.00	01696200-54412	OTHER EQUIPMENT	252070CR 2910
	<u>-2,854.00</u>			
HIGH PSI LIMITED				
EQUIP. PARTS/SERVICE	192.00	04201600-53317	OPERATING SUPPLIES	31430
	<u>192.00</u>			
HOLSTEIN'S GARAGE				
INSP 10,3,72,40,71,67	174.00	01696200-53353	OUTSOURCING SERVICES	379710/27/11
INSP 60,65,41	101.00	01696200-53353	OUTSOURCING SERVICES	3797 11/11
TRK INSP 82 & 75	58.00	01696200-53353	OUTSOURCING SERVICES	3797A
TRK INSPS 44 &45	58.00	01696200-53353	OUTSOURCING SERVICES	37984/2/11
	<u>391.00</u>			
HOME DEPOT				
AIR COMP 4 TRUCK	5.78	04201600-53317	OPERATING SUPPLIES	0202804
CLEANER 2 MOP PUMP ST	8.57	04201600-53317	OPERATING SUPPLIES	0148577
ELECT PARTS 4 OUTLET	23.12	04201600-53317	OPERATING SUPPLIES	0148577
LIGHT BULBS	10.94	04201600-53317	OPERATING SUPPLIES	0233213
MATERIAL	6.02	04201600-53317	OPERATING SUPPLIES	0287920
PARTS	4.60	01670500-53317	OPERATING SUPPLIES	0266957
PARTS-TIRE	19.97	01696200-53354	PARTS PURCHASED	0273797
REMODEL MATERIALS	33.54	01643700-53350	SMALL EQUIPMENT EXPENSE	5956719
REMODEL MATERIALS	85.99	01643700-53350	SMALL EQUIPMENT EXPENSE	0294801
REPAIR SUPPLY 4 TRUCK	37.24	04201600-53317	OPERATING SUPPLIES	0289355
SUPPLIES	40.46	04201600-53317	OPERATING SUPPLIES	0283986
SUPPLIES	100.00	01670200-53316	TOOLS	0174854
SUPPLIES	80.12	01670700-53316	TOOLS	0277897
SUPPLIES	100.00	01670400-53316	TOOLS	0277897
SUPPLIES	100.00	01670600-53316	TOOLS	0277897
SUPPLIES -	19.88	01670700-53316	TOOLS	0174854
TARP	64.98	04201600-53317	OPERATING SUPPLIES	0152637
TOOLS FOR HYD REPAIR	71.80	04201600-53317	OPERATING SUPPLIES	9919317
TRAPS/POISON	7.92	04201600-53317	OPERATING SUPPLIES	0275313
TRAPS/POISON	19.67	04201600-53317	OPERATING SUPPLIES	0525352
	<u>840.60</u>			
HOTELS-MASTERCARD				
NUTI FOR LUCAS	595.90	01662700-52223	TRAINING	319776A
	<u>595.90</u>			
ICCI				
MEMBERSHIP DUES VOCS	125.00	01643700-52234	DUES & SUBSCRIPTIONS	VZUP2FF7CCC8

PERMIT TEC MICHALEK	180.00	01643700-52223	TRAINING	41069433
	305.00			
IGFOA				
CAFR AWARD	435.00	01612900-52234	DUES & SUBSCRIPTIONS	FY 2011
IGFOA MEETING-BATEK	30.00	01610100-52222	MEETINGS	4467967
IGFOA MEETING-WYDRA	30.00	01612900-52222	MEETINGS	4467993
IGFOA MTG-DAMOLARIS	30.00	01612900-52222	MEETINGS	4467952
	525.00			
IRMA				
NOVEMBER MONTHLY DEDUCTIBLE	3,714.54	01650100-52215	INSURANCE DEDUCTIBLES	11149
NOVEMBER OPTIONAL DEDUCTIBLE	16,344.70	01650100-52215	INSURANCE DEDUCTIBLES	11129
VOLUNTEER COVERAGE 11/11- 11/12	527.00	01664700-51114	WORKERS COMP	8156
	20,586.24			
ILLINOIS ASSN OF CHIEFS OF POLICE				
MEMB DUES E SAILER	85.00	01660100-52234	DUES & SUBSCRIPTIONS	ILACP2011
MEMB DUES K ORR	200.00	01660100-52234	DUES & SUBSCRIPTIONS	9409
	285.00			
ILLINOIS CITY COUNTY MANAGEMENT ASSN				
SOCIAL MEDIA REBHOLZ	25.00	01600000-52223	TRAINING	5982226
	25.00			
ILLINOIS SECRETARY OF STATE				
619 REGISTRATION	108.22	01664754-52212	AUTO MAINTENANCE & REPAIR	FORD PU
CONVENIENCEFEE	4.15	01660154-52212	AUTO MAINTENANCE & REPAIR	11/7/11
PLATE STK 607	99.00	01664754-52212	AUTO MAINTENANCE & REPAIR	CHV AVALANCH
PLATE STK 657	99.00	01662454-52212	AUTO MAINTENANCE & REPAIR	BLUE VAN
NOTARY COMM RENEWAL LEUZE	10.00	01662600-52234	DUES & SUBSCRIPTIONS	CHERYL LEUZE
	320.37			
INDUSTRIAL TOOL BOX				
CAUTION TAPE/KRYLON	886.16	01670300-53317	OPERATING SUPPLIES	34992
	886.16			
INTERNET PURCHASE MASTERCARD				
CLASSIC EARPLUG	43.70	01670400-53317	OPERATING SUPPLIES	5281019
EAR PLUGS	30.23	04201600-53317	OPERATING SUPPLIES	9530643
MONEY MAGAZINE	127.50	01643600-52246	ECONOMIC DEVELOPMENT	30491166
PRINTED MATERIALS	14.97	01641700-53318	REFERENCE MATERIALS	105-5208298
ROLLCALL PRINTER TRAY	87.18	01652800-54412	OTHER EQUIPMENT	51801
RUBBER STAMPS	19.95	01696200-53314	OFFICE SUPPLIES	8032616
SERGEANT TESTING BOOK	335.74	01660100-53318	REFERENCE MATERIALS	5697840
STEEL TOOL CART	146.48	01696200-53350	SMALL EQUIPMENT EXPENSE	2665024

TREE LIGHTING SUPPLIES	305.04	01750000-52291	MISC EVENTS/ACTIVITIES	82027	
	1,110.79				
INVENTORY TRADING CO					
UNIFM SHIRT DUMOULIN	148.75	01662400-53324	UNIFORMS	213457	
	148.75				
JACKSON HIRSH INC					
SUPPLIES 11/2/11	32.31	04201600-53317	OPERATING SUPPLIES	0816090	
SUPPLIES 11/2/11	32.32	01670100-53317	OPERATING SUPPLIES	0816090	
	64.63				
JEWEL-OSCO					
CITIZEN CORP	30.97	01664778-53325	COMMUNITY RELATIONS	0062407	
	30.97				
JOE COTTON FORD					
PART - MODULE	259.03	01696200-53354	PARTS PURCHASED	296854	
PART-LAMP ASY	131.90	01696200-53354	PARTS PURCHASED	296992	
PART-RIVET	7.74	01696200-53354	PARTS PURCHASED	297040	
PARTS-SWITCH ASY	108.75	01696200-53354	PARTS PURCHASED	297133	
PARTS-WIRE	8.80	01696200-53354	PARTS PURCHASED	296949	
	516.22				
JOHN E REID & ASSOCIATES INC					
INTV/INTERG CLUEVER & WALKER	297.50	01662300-52223	TRAINING	124826	
INTV/INTRG WALKER	297.50	01662700-52223	TRAINING	124826	
	595.00				
KANE, MCKENNA AND ASSOCIATES INC					
NORTH/SCHMALE TIF DISTRICT	675.00	01650100-57499	CONTINGENCY	10764	20120055
	675.00				
KENNETH LYNCH & SONS INC					
BAL PD FOR TC BENCH	885.00	01680000-53381	TC MAINTENANCE & SUPPLIES	44554-1	
	885.00				
KLEIN, THORPE & JENKINS, LTD					
LEGAL SERVICES RENDERED THRU 10/30/2011	435.50	11740000-52238	LEGAL FEES	11/28/11	
LEGAL SERVICES RENDERED THRU 10/30/2011	546.00	21500000-52238	LEGAL FEES	11/28/11	
LEGAL SERVICES RENDERED THRU 10/30/2011	780.00	04200100-52238	LEGAL FEES	11/28/11	
LEGAL SERVICES RENDERED THRU 10/30/2011	2,465.40	01650100-57499	CONTINGENCY	11/28/11	
LEGAL SERVICES RENDERED THRU 10/30/2011	5,672.89	01570000-52238	LEGAL FEES	11/28/11	
	9,899.79				
KOHL'S					
CLOTH ALLOW - GREY	101.98	01664700-53324	UNIFORMS	571006103702	

UNIFM PANTS DUMOULIN	114.95	01662400-53324	UNIFORMS	6500267830
	<u>216.93</u>			
KONICA MINOLTA BUSINESS SOLUTIONS				
MTNCE THRU 11/23/12	695.92	01612900-52226	OFFICE EQUIPMENT MAINTENANCE	219220776
	<u>695.92</u>			
KPW TRUCKING INC				
HAULING DEBRI	325.00	01670500-52265	HAULING	723
HAULING DEBRI	689.75	01670600-53317	OPERATING SUPPLIES	723
	<u>1,014.75</u>			
LAW ENFORCEMENT TARGETS INC				
CARDBOARD TARGETS	357.54	01662700-53317	OPERATING SUPPLIES	0176922-IN
	<u>357.54</u>			
LENS ACE HARDWARE #426				
WNTR GEAR STRIK/KRAUS	220.99	04201600-53324	UNIFORMS	78386
	<u>220.99</u>			
LIVE VIEW GPS INC				
MONTHLY FEE - NOV '11	79.90	01664700-53330	INVESTIGATION FUND	66475
	<u>79.90</u>			
LOWE'S HOME CENTERS				
ALARM	17.78	01670400-53317	OPERATING SUPPLIES	10879
BOLTS FOR BENCHES	6.24	01680000-53319	MAINTENANCE SUPPLIES	09655
BOLTS, WASHERS BENCH	16.17	01680000-53319	MAINTENANCE SUPPLIES	08748
CABLE-BREATHALIZER	20.40	01652800-53317	OPERATING SUPPLIES	14095
CUTTERS 4 TRUCK	75.93	04201600-53350	SMALL EQUIPMENT EXPENSE	10217
FIRE EXT & LOCK	41.64	01680000-53319	MAINTENANCE SUPPLIES	02174
GLOW STICKS LOW LITE	29.70	01662700-53317	OPERATING SUPPLIES	09129
LIGHTS -TWN CTR	4.47	01680000-53319	MAINTENANCE SUPPLIES	10266
LOCK PRTS FRM HOUSE	35.37	01680000-53319	MAINTENANCE SUPPLIES	09651
LOCK/PARTS	15.30	01680000-53319	MAINTENANCE SUPPLIES	14850
MATERIALS	30.68	04201600-53317	OPERATING SUPPLIES	02939
PLYWOOD	5.27	01680000-53319	MAINTENANCE SUPPLIES	02761
RTN'D PARTS	-4.40	01680000-53319	MAINTENANCE SUPPLIES	16152
SEALANT	12.04	04201600-53317	OPERATING SUPPLIES	09511
TOGGLE BOLTS,FILTERS	21.68	01680000-53319	MAINTENANCE SUPPLIES	10941
	<u>328.27</u>			
MAACO COLLISION REPAIR & AUTO PAINTING				
RPR 2001 INTN'L TRUCK	95.00	01696200-53353	OUTSOURCING SERVICES	4087
	<u>95.00</u>			
MARSHALLS				

CLOTH ALLOW - CHACON	94.99	01662400-53324	UNIFORMS	0711067369	
CLOTH ALLOW - JONES	52.96	01662400-53324	UNIFORMS	0711041940	
	147.95				
MDI WORLDWIDE					
REF GUIDES FOR TRUCKS	200.88	04201600-52223	TRAINING	00386374	
	200.88				
MENARDS					
ADHESIVE	2.40	01670200-53317	OPERATING SUPPLIES	73023100819	
	2.40				
MICHAELS LANDSCAPING					
LAWN MOWING 510,520 SILVERLEAF, 376 ILLINI	375.00	01670400-52272	PROPERTY MAINTENANCE	12/12/11	
	375.00				
MINUTEMAN PRESS					
BC EILEEN MOLLOY	38.12	01662500-53314	OFFICE SUPPLIES	33942	
BC RYAN RAINEY	38.12	01660100-53314	OFFICE SUPPLIES	33942	
BC STEVE DUMOULI	38.12	01662400-53314	OFFICE SUPPLIES	33942	
BC DAN HOFFMAN	38.12	01660100-53314	OFFICE SUPPLIES	33942	
BC JEFF DEGNAN	38.12	01660100-53314	OFFICE SUPPLIES	33942	
BC KATHLEEN MCNA	38.12	01662500-53314	OFFICE SUPPLIES	33942	
BC PETE CHACON	38.12	01662400-53314	OFFICE SUPPLIES	33942	
BC POLICE DEPT	38.12	01662500-53314	OFFICE SUPPLIES	33942	
	304.96				
MONROE TRUCK EQUIPMENT					
PLOW PARTS	246.30	01696200-53354	PARTS PURCHASED	290906	
	246.30				
MR SITCO					
WATER METER READINGS-DEC/2011	1,634.10	04103100-52221	UTILITY BILL PROCESSING	201231	20120003
WATER METER READINGS-DEC/2011	1,634.10	04203100-52221	UTILITY BILL PROCESSING	201231	20120003
	3,268.20				
MTS SAFETY PRODUCTS INC					
TRAFFIC VESTS	538.70	01662700-53324	UNIFORMS	3563700	
	538.70				
N P E L R A					
2012 NPELRA & IPELKA	190.00	01600000-52234	DUES & SUBSCRIPTIONS	REBHOLZ27920	
	190.00				
NAPA AUTO CENTER					
FUEL FILTER	50.64	01696200-53354	PARTS PURCHASED	142751	
SUPPLIES	86.59	01696200-53317	OPERATING SUPPLIES	145524	

	<u>137.23</u>			
NATIONAL ENGRAVERS				
RETIREMENT PICTURES	140.00	01660100-53317	OPERATING SUPPLIES	17335
	<u>140.00</u>			
NEOPOST LEASING				
POSTG MTC 12/2011	422.44	01650100-52226	OFFICE EQUIPMENT MAINTENANCE N2885152	
	<u>422.44</u>			
NICOR GAS				
SERV FRM 11/04 THRU 12/07	141.10	04201600-52277	HEATING GAS	13811210007NOV/11
SERV FRM 11/07 - 12/08	82.82	04101500-52277	HEATING GAS	86 60 60 11178 NOV
	<u>223.92</u>			
NIU OUTREACH (I G F O A)				
TRAINING CLASS -DAVIS	178.00	01590000-52223	TRAINING	386712
	<u>178.00</u>			
NMI				
VEHICLE STICKER FEES	10.00	01610100-52256	BANKING SERVICES	NOV 2011
	<u>10.00</u>			
NORTH AMERICAN SALT COMPANY				
3500 TONS OF BULK ROCK SALT	32,969.26	06320000-53335	SALT	70761824
	<u>32,969.26</u>			20120051
NORTHEASTERN ILLINOIS PUBLIC SAFETY				
SNOW PLOW DRIVER TRAINING 10/05/11	200.00	01670100-52223	TRAINING	8189
	<u>200.00</u>			
NOTARIES ASSOCIATION OF ILL INC				
CHERYL LEUZE NOTARY COMM RNWL	38.00	01662600-52234	DUES & SUBSCRIPTIONS	C LEUZE RNWL
	<u>38.00</u>			
OCE IMAGISTICS INC				
COPIER OCT/11	21.39	04100100-52231	COPY EXPENSE	416643115
COPIER OCT/11	21.39	04200100-52231	COPY EXPENSE	416643115
	<u>42.78</u>			
OFFICE DEPOT				
BUSINESS ENVELOPES	5.37	01660100-53314	OFFICE SUPPLIES	586108560
CALENDER/APT BOOK	9.28	01600000-53314	OFFICE SUPPLIES	585492339
LABELS	25.41	01662400-53314	OFFICE SUPPLIES	585360363001
OFFICE SUPPLIES	9.74	01643700-53314	OFFICE SUPPLIES	584190413
OFFICE SUPPLIES	58.99	01620100-53314	OFFICE SUPPLIES	586461953001
OFFICE SUPPLIES	83.80	01643700-53314	OFFICE SUPPLIES	584190176
OFFICE SUPPLY 11/17	13.78	01690100-53314	OFFICE SUPPLIES	587250742

OFFICE SUPPLY 11/17	21.33	04200100-53314	OFFICE SUPPLIES	587250742	
OFFICE SUPPLY 11/17	110.38	01670100-53314	OFFICE SUPPLIES	587250742	
RETURN OFF. SUPPLIES	-39.98	01643700-53314	OFFICE SUPPLIES	584424109	
TONER CARTRIDGE	76.76	01600000-53314	OFFICE SUPPLIES	585492762	
	374.86				
OLD NAVY					
JEANS- MOZALEWSKI	123.00	01670100-53324	UNIFORMS	6112	
	123.00				
OMI					
MONTHLY WRC OPERATIONS-JAN/2012	134,927.59	04101100-52262	WRC CONTRACT	53103	20120012
	134,927.59				
ONLINE STORES.COM					
SAFETY GEAR 11/14	17.40	01696200-53324	UNIFORMS	SE1908942	
SAFETY GEAR 11/14	52.20	04200100-53324	UNIFORMS	SE1908942	
SAFETY GEAR 11/14	81.20	01670100-53324	UNIFORMS	SE1908942	
SAFETY GEAR 12/01	5.80	01670100-53324	UNIFORMS	SE1939913	
	156.60				
OZINGA READY MIX CONCRETE INC					
CONCRETE	2,478.00	06320000-53338	CONCRETE	201628	
	2,478.00				
P & G KEENE ELECTRICAL REBUILDERS LLC					
PART-ALTERNATOR	218.00	01696200-53354	PARTS PURCHASED	338293	
	218.00				
P & M MERCURY MECHANIC					
HVAC MTC 11/11-01/12	720.00	01680000-52244	MAINTENANCE & REPAIR	63814	
	720.00				
PAT MCDONALD					
RETIREMENT PORTRAITS 11/2/11	52.00	01662700-53317	OPERATING SUPPLIES	100	
	52.00				
PAVIA MARTING & CO					
BRIDGE & CULVERT INSPECT'S NOV/11	1,099.86	01622200-52253	CONSULTANT	11086	20120059
	1,099.86				
POMPS TIRE SERVICE					
TIRES	1,370.66	01696200-53354	PARTS PURCHASED	818175	
	1,370.66				
POSITIONING SOLUTIONS					
LOOSE LEAF FILLER	8.58	01622200-53317	OPERATING SUPPLIES	1091415	

8.58**PROSAFETY**

SPRAY PAINT 10/31/11	186.40	04201600-53317	OPERATING SUPPLIES	710130
WORK GLOVES 10/31/11	208.00	04101500-53317	OPERATING SUPPLIES	710130
	<hr/> 394.40			

RADCO COMMUNICATIONS INC

678 REPAIR	74.70	01662700-52212	AUTO MAINTENANCE & REPAIR	77162
694 CHANGEOVER	570.70	01664700-52212	AUTO MAINTENANCE & REPAIR	77162
697 REPAIR	28.30	01662300-52212	AUTO MAINTENANCE & REPAIR	77162
697CHANGEOVER	777.50	01662300-52212	AUTO MAINTENANCE & REPAIR	77162
698 REPAIR	159.95	01660100-52212	AUTO MAINTENANCE & REPAIR	77162
LARSEN RADIO REPAIR	244.62	01662700-52227	RADIO MAINTENANCE	77212
REPAIR 651	707.50	01662700-52212	AUTO MAINTENANCE & REPAIR	77144
REPAIR 683	35.00	01662700-52212	AUTO MAINTENANCE & REPAIR	77144
REPAIR 686	430.70	01662700-52212	AUTO MAINTENANCE & REPAIR	77144
REPR 645	570.70	01664700-52212	AUTO MAINTENANCE & REPAIR	77101
REPR 681/683	510.70	01662700-52212	AUTO MAINTENANCE & REPAIR	77101
	<hr/> 4,110.37			

RADIOSHACK

HDMI CABLE-ROLL CALL	39.99	01652800-53317	OPERATING SUPPLIES	032716
	<hr/> 39.99			

RAY O'HERRON CO

BRADLEY SHOES	81.95	01662700-53324	UNIFORMS	0044225
BUCHOLZ UNIFORM	152.00	01662700-53324	UNIFORMS	0044323
CUMMINGS PANTS	110.85	01664700-53324	UNIFORMS	0044609
CUMMINGS UNIFORM	605.50	01662400-53324	UNIFORMS	0043966
DO'BRIEN	86.95	01662700-53324	UNIFORMS	0043926
DUMOULIN	36.80	01660100-53324	UNIFORMS	0043923
EBY UNIFORM	102.00	01664700-53324	UNIFORMS	0044526
GRAY	83.95	01662700-53324	UNIFORMS	0043925
HARKER UNIFORM	73.90	01662700-53324	UNIFORMS	0044527
HOFFMAN	83.95	01660100-53324	UNIFORMS	0043924
JLOPEZ	96.00	01662700-53324	UNIFORMS	0043921
JOHNSON UNIFORM	154.95	01662700-53324	UNIFORMS	0044233
JUNGERS	15.95	01660100-53324	UNIFORMS	0043922
JUNGERS UNIFORM	73.90	01660100-53324	UNIFORMS	0044528
O'BRIEN BOOTS	24.00	01662700-53324	UNIFORMS	0044463
O'BRIEN, LAPORT RETIR	52.90	01660100-53324	UNIFORMS	0044167
PASKEVICZ BELT	78.95	01662700-53324	UNIFORMS	0043965
PLUMB UNIFORM	147.90	01662700-53324	UNIFORMS	0044232
STAFIEJ UNIFORM	103.90	01662700-53324	UNIFORMS	0044231

TAX UNIFORM	51.95	01662700-53324	UNIFORMS	0044226
WALKER HOLSTER	198.95	01664700-53324	UNIFORMS	0044610
ZALAK UNIFORM	51.95	01662700-53324	UNIFORMS	0044227
	<u>2,469.15</u>			
RESTAURANT-MASTERCARD				
CITIZEN CORP	120.00	01664778-53325	COMMUNITY RELATIONS	223 10/27/11
CITIZEN CORP	120.50	01664778-53325	COMMUNITY RELATIONS	230 11/17/11
CITIZEN CORP	120.99	01664778-53325	COMMUNITY RELATIONS	230 11/10/11
CITIZEN CORP	158.20	01664778-53325	COMMUNITY RELATIONS	223 11/3/11
RED CRS TRAINING	71.26	01662500-53317	OPERATING SUPPLIES	140333
	<u>590.95</u>			
SAUBER MGF.CO				
REPAIR BOTT DRAWER	36.70	01696200-53353	OUTSOURCING SERVICES	151311
	<u>36.70</u>			
SEAWAY SUPPLY CO				
WINTER SUPPLIES	251.30	01670200-53317	OPERATING SUPPLIES	77723
	<u>251.30</u>			
SHEMIN NURSERIES				
RESTR 4 TREE RMOVL5	244.20	01670700-53317	OPERATING SUPPLIES	779232
	<u>244.20</u>			
SHERWIN INDUSTRIES INC				
BARRICADE LIGHTS	768.00	01670300-53317	OPERATING SUPPLIES	044015
MAN HOLE RINGS	204.58	01670600-53317	OPERATING SUPPLIES	043846
	<u>972.58</u>			
SIGN A RAMA				
SIGNAGE 4 TRUCKS	490.00	01696200-53353	OUTSOURCING SERVICES	36020
	<u>490.00</u>			
SIGNS NOW				
NAME MAGNET FOR INV	20.00	01662400-53317	OPERATING SUPPLIES	195-41474
	<u>20.00</u>			
SIMPLEX GRINNELL				
CONTRT OCT/11-SEPT/12	623.00	04201600-52244	MAINTENANCE & REPAIR	74713311
TESTING:DRYSPRINKLERS	527.67	04201600-52244	MAINTENANCE & REPAIR	74622502
SPRINKLER REPAIR	690.25	04201600-52244	MAINTENANCE & REPAIR	67240610
	<u>1,840.92</u>			
SNAP ON INDUSTRIAL				
CLAMP	143.02	01696200-53316	TOOLS	15806943
	<u>143.02</u>			

STEINER ELECTRIC COMPANY

BREAKS FOR TRUCK	59.53	04201600-53317	OPERATING SUPPLIES	S003789905
	<u>59.53</u>			

STEVE PIPER & SONS INC

TUB GRINDER	1,900.00	01670700-52264	EQUIPMENT RENTAL	128155
	<u>1,900.00</u>			

STIPES PUBLISHING LLC

LAW UPDATES BOOKS	164.32	01662400-53318	REFERENCE MATERIALS	110311
	<u>164.32</u>			

STREICHERS

ENTRY RAM	370.00	01664700-53330	INVESTIGATION FUND	S991285
	<u>370.00</u>			

SUBURBAN DRIVELINE INC

PART-CONTROLLER	450.00	01696200-53354	PARTS PURCHASED	00130014
PLASTIC DEFLECTORS	525.00	01696200-53354	PARTS PURCHASED	00129978
	<u>975.00</u>			

SUBURBAN LABORATORIES INC

COLIFORM TESTING	184.00	04201600-52279	LAB SERVICES	13399
	<u>184.00</u>			

SUMMIT RACING EQUIPMENT

PART-STAIN. STEEL BAR	411.85	01696200-53354	PARTS PURCHASED	2203126
STAIN.STEEL BAR	211.40	01696200-53354	PARTS PURCHASED	2094416
	<u>623.25</u>			

SUNRISE CHEVROLET

PANEL	26.20	01696200-53354	PARTS PURCHASED	758125
PARTS	25.83	01696200-53354	PARTS PURCHASED	768223
PARTS-SHIELD	20.43	01696200-53354	PARTS PURCHASED	767894
	<u>72.46</u>			

SUPER CASUALS

PW SWEATSHIRTS	79.98	01670100-53324	UNIFORMS	202245
PW SWEATSHIRTS 11/18	234.95	01670100-53324	UNIFORMS	202215
W&S SWEATSHIRTS 11/18	234.95	04200100-53324	UNIFORMS	202215
	<u>549.88</u>			

SUPER ONE HOUR CLEANER

MABBIT DRY CLEANING	6.95	01662700-53317	OPERATING SUPPLIES	22541
	<u>6.95</u>			

THEODORE POLYGRAPH SERVICE

POLY FOR POLICE OFFCR CANDIDATES	540.00	01510000-52228	PERSONNEL HIRING	3073	
	540.00				
THIRD MILLENIUM ASSOCIATES INCORPORATED					
UTILITY BILL EPAY NOV/11	225.00	04103100-52221	UTILITY BILL PROCESSING	14115	20120004
UTILITY BILL EPAY NOV/11	225.00	04203100-52221	UTILITY BILL PROCESSING	14115	20120004
UTILITY BILL PROCESS-NOV/11	1,146.44	04103100-52221	UTILITY BILL PROCESSING	14114	20120004
UTILITY BILL PROCESS-NOV/11	1,146.44	04203100-52221	UTILITY BILL PROCESSING	14114	20120004
	2,742.88				
THYSENDRUPP ELEVATOR CORP					
ELEV INSP 11/11-1/12	553.88	01680000-52244	MAINTENANCE & REPAIR	3000091452	
	553.88				
TIC TANK INDUSTRY CONSULTANTS					
LIES RD TANK SPRINT ANTENNA INSTALL UPGD	3,500.00	04200100-52253	CONSULTANT	27068	
	3,500.00				
TIGERDIRECT.COM					
CABLES AND DUSTER	10.11	01662700-53317	OPERATING SUPPLIES	750102A	
CANNON DIGITAL CAMERA	99.99	01662700-53350	SMALL EQUIPMENT EXPENSE	750102	
LASER MOUSE	26.99	01662700-53317	OPERATING SUPPLIES	F7724707	
MEDIA	671.20	01662759-53317	OPERATING SUPPLIES	77247070101	
VOICE RECORDER	86.56	01660100-53317	OPERATING SUPPLIES	750101	
	894.85				
TITAN SUPPLY INC					
JANITORIAL SUPPLIES	555.10	01680000-52276	JANITORIAL SERVICES	3172	
	555.10				
TRAFFIC CONTROL & PROTECTION					
SIGNS	97.10	01670300-53344	STREET SIGNS	70985	
SIGNS	151.50	01670300-53344	STREET SIGNS	70986	
SIGNS	254.40	01670300-53344	STREET SIGNS	71094	
	503.00				
TRAVEL-MASTERCARD					
PARKING FOR TRAINING	8.00	01662500-52223	TRAINING	MBT111811	
	8.00				
TRUGREEN					
ICE MELT	450.00	01680000-53319	MAINTENANCE SUPPLIES	215284	
RETAIL ICE MELT	450.00	01680000-53319	MAINTENANCE SUPPLIES	215286	
	900.00				
U S POST OFFICE					
POSTG MTC LASER UNIT	12.60	01662300-53317	OPERATING SUPPLIES	477	

12.60**UNI MAX MANAGEMENT CORP**JANITORIAL SERV VLG HL/PWK-DEC/11
JANITORIAL SERV VLG HL/PWK-DEC/11623.75
1,871.2501670100-52276
01680000-52276JANITORIAL SERVICES
JANITORIAL SERVICES2354
235420120033
20120033

2,495.00**UNIFIRST CORPORATION**TOWELS/MATS 10/25/11
TOWELS/MATS 10/25/11
TOWELS/MATS 11/1/11
TOWELS/MATS 11/15
TOWELS/MATS-11/8/11
UNIFORM CLNG 10/25/11
UNIFORM CLNG 11/1/11
UNIFORM CLNG 11/15
UNIFORM CLNG-11/8/1138.52
50.80
94.07
89.32
89.32
47.07
47.07
47.07
47.0701670100-53317
01696200-53317
01696200-53317
01696200-53317
01696200-53317
01696200-52267
01696200-52267
01696200-52267
01696200-52267OPERATING SUPPLIES
OPERATING SUPPLIES
OPERATING SUPPLIES
OPERATING SUPPLIES
OPERATING SUPPLIES
UNIFORM CLEANING
UNIFORM CLEANING
UNIFORM CLEANING
UNIFORM CLEANING742322
742322
744305
748268
746292
742322
744305
748268
746292

550.31**UNITED LABORATORIES**

SOLAR SOLVENT

310.36

01670200-53317

OPERATING SUPPLIES

28500

310.36**UPS GROUND SERVICE**

COBAN RETURN

9.01

01662700-53317

OPERATING SUPPLIES

1ZV056T70396

9.01**USA BLUE BOOK**HARNESS
MARKING PAINT123.45
45.2404101100-53317
01670700-53317OPERATING SUPPLIES
OPERATING SUPPLIES530156
512688

168.69**VERIZON WIRELESS**SRV 9/14-10/13
SRV 9/14-10/13
SRV 9/14-10/13
SRV 9/14-10/13
SRV 9/14-10/131.69
75.98
151.96
189.95
759.8001660100-52230
01664700-52230
01662300-52230
01660100-52230
01662700-52230TELEPHONE
TELEPHONE
TELEPHONE
TELEPHONE
TELEPHONE2643626063
2643626063
2643626063
2643626063
2643626063

1,179.38**VERMEER ILLINOIS**

PARTS-THROTTLE

91.61

01696200-53354

PARTS PURCHASED

P42905

91.61**VILLA PARK MATERIAL COMPANY INC**BLOCKS
BLOCKS120.00
120.0001670400-53317
01670400-53317OPERATING SUPPLIES
OPERATING SUPPLIES95420
95468

BLOCKS	180.00	01670400-53317	OPERATING SUPPLIES	95426	
BLOCKS	180.00	01670400-53317	OPERATING SUPPLIES	95460	
BLOCKS	360.00	01670400-53317	OPERATING SUPPLIES	95451	
BLOCKS	600.00	01670400-53317	OPERATING SUPPLIES	95470	
	<u>1,560.00</u>				
WEST SIDE TRACTOR SALES					
PART-THROTTLE CABLE	158.50	01696200-53354	PARTS PURCHASED	66980	
PARTS-PEDAL	447.23	01696200-53354	PARTS PURCHASED	67043	
	<u>605.73</u>				
WINTER EQUIPMENT COMPANY INC					
SNOW PLOW PART	365.64	01696200-53354	PARTS PURCHASED	12753	
	<u>365.64</u>				
XEROX CAPITAL SERVICES LLC					
LEASE 11/2011	1,665.46	01650100-52231	COPY EXPENSE	058109596	20120021
	<u>1,665.46</u>				
ZIEGLERS ACE HARWARE					
KEY RING HOLDER	5.99	01662400-53317	OPERATING SUPPLIES	H48535	
	<u>5.99</u>				
GRAND TOTAL	<u><u>\$376,173.74</u></u>				

The preceding list of bills payable totaling \$376,173.74 was reviewed and approved for payment.

Approved by:

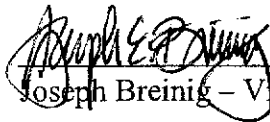

Joseph Breinig - Village Manager

Date: 12/16/11

Authorized by:

Frank Saverino Sr - Mayor

Beth Melody, Village Clerk

Date: _____

AGENDA ITEM

K-2 12-19-11

ADDENDUM WARRANTS December 6 2011 thru December 19, 2011

Fund	Check #	Vendor	Description	Amount
General	A C H	Charter One Bank	Payroll Nov 28 2011 thru Dec 11 2011	413,184.53
Water & Sewer	A C H	Charter One Bank	Payroll Nov 28 2011 thru Dec 11 2011	32,682.45
General	A C H	Ill Funds	I P B C for December 2011	221,526.96
Water & Sewer	A C H	Ill Funds	I P B C for December 2011	<u>18,305.01</u>
				<u>685,698.95</u>

Approved this _____ day of _____, 2011

By: _____
Frank Saverino Sr - Mayor

Beth Melody - Village Clerk



AGENDA ITEM

Village of Carol Stream L-3 12-19-11

FRANK SAVERINO, SR., MAYOR • BETH MELODY, CLERK • JOSEPH E. BREINIG, MANAGER
500 N. GARY AVENUE • CAROL STREAM, ILLINOIS 60188-1899
(630) 665-7050 • FAX (630) 665-1064
www.carolstream.org

PUBLIC NOTICE is hereby given that the regularly scheduled meetings of the President and Board of Trustees and Commissions/Committees of the Village of Carol Stream are as follows for the calendar year, 2012:

VILLAGE BOARD MEETINGS

(1ST & 3RD Mondays each month)
8:00 PM

January 17, 2012	May 7, 2012	September 4, 2012
February 6, 2012	May 21, 2012	September 17, 2012
February 21, 2012	June 4, 2012	October 1, 2012
March 5, 2012	June 18, 2012	October 15, 2012
March 19, 2012	July 2, 2012	November 5, 2012
April 2, 2012	July 16, 2012	November 19, 2012
April 16, 2012	August 6, 2012	December 3, 2012
	August 20, 2012	December 17, 2012

PLAN COMMISSION/ZONING BOARD OF APPEALS

(2ND & 4TH Mondays each month)
7:30 PM

January 9, 2012	May 14, 2012	September 10, 2012
January 23, 2012	May 28, 2012	September 24, 2012
February 13, 2012	June 11, 2012	October 8, 2012
February 27, 2012	June 25, 2012	October 22, 2012
March 12, 2012	July 9, 2012	November 12, 2012
March 26, 2012	July 23, 2012	November 26, 2012
April 9, 2012	August 13, 2012	December 10, 2012
April 23, 2012	August 27, 2012	

FIRE/POLICE COMMISSION

There are no regularly scheduled meetings.
The Commission meets only as cases arise.

POLICE PENSION BOARD

The Pension Board holds quarterly meetings.

I, Beth Melody, Village Clerk for the Village of Carol Stream DuPage County, Illinois do certify that the above schedule was posted on the Public Information Bulletin Board at the Municipal Building, 500 N. Gary Avenue, Carol Stream, Illinois on this 20th day of December, 2011.

Beth Melody
Village Clerk

Village of Carol Stream
General Fund Budget Summary
 For the Month Ended November 30, 2011

AGENDA ITEM

L-4 12-19-11

MONTH

YTD

BUDGET

REVENUES

	MONTH		Monthly Variance		YTD		YTD Variance		BUDGET		YTD Variance		
	Last Year Nov	Current Year Nov	\$	%	Last Year YTD	Current Year YTD	\$	%	Annual Budget	YTD Budget	YTD Actual	\$	%
Sales Tax	\$ 427,448	\$ 441,850	14,401	3%	\$ 2,855,148	\$ 2,878,441	23,293	1%	\$ 4,915,000	\$ 2,904,247	\$ 2,878,441	(25,806)	-1%
Home Rule Sales Tax	232,499	252,146	19,647	8%	1,176,489	1,650,888	474,399	40%	2,654,000	1,568,193	1,650,888	82,694	5%
State Income Tax	221,874	205,694	(16,180)	-7%	1,836,306	1,866,418	30,112	2%	3,140,000	1,875,031	1,866,418	(8,613)	0%
Utility Tax - Electricity	135,953	134,398	(1,555)	-1%	1,109,890	1,085,796	(24,094)	-2%	1,750,000	1,031,521	1,085,796	54,275	5%
Telecommunications Tax	114,023	136,221	22,198	19%	964,019	954,696	(9,323)	-1%	1,558,000	907,048	954,696	47,648	5%
Fines (Court, Ord., ATLE, Towing)	133,368	119,570	(13,798)	-10%	1,007,167	817,118	(190,049)	-19%	1,708,000	989,743	817,118	(172,626)	-17%
Natural Gas Use Tax	19,117	21,526	2,408	13%	144,523	178,879	34,356	24%	525,000	157,870	178,879	21,009	13%
Other Taxes (Use, Hotel, PPRT													
Real Estate, Road & Bridge)	86,962	149,505	62,542	72%	878,815	1,227,538	348,724	40%	1,235,000	863,354	1,227,538	364,184	42%
Licenses (Vehicle, Liquor, etc.)	5,917	11,459	5,543	94%	429,722	430,506	784	0%	599,300	444,658	430,506	(14,152)	-3%
Cable Franchise Fees	67,162	40,851	(26,311)	-39%	310,892	298,742	(12,150)	-4%	460,000	268,333	298,742	30,408	11%
Building Permits	56,443	38,056	(18,387)	-33%	321,997	378,156	56,159	17%	492,500	341,758	378,156	36,398	11%
Fees for Services	44,758	54,702	9,944	22%	383,551	384,103	552	0%	593,500	379,003	384,103	5,100	1%
Interest Income	2,978	2,707	(271)	-9%	23,548	20,238	(3,310)	-14%	40,000	23,333	20,238	(3,096)	-13%
All Other / Miscellaneous	68,640	27,149	(41,491)	-60%	362,211	546,297	184,085	51%	414,200	251,617	546,297	294,680	117%
Revenue Totals	1,617,143	1,635,833	18,690	1%	11,804,278	12,717,815	913,538	8%	20,084,500	12,005,711	12,717,815	712,104	6%

EXPENDITURES

Fire & Police Commission	-	-	-	0%	14,560	472	(14,088)	-97%	18,198	10,618	472	(10,146)	-96%
Legislative Board	6,038	7,112	1,075	18%	83,712	88,858	5,146	6%	108,706	91,659	88,858	(2,801)	-3%
Plan Commission & ZBA	367	40	(327)	-89%	2,858	3,706	848	30%	6,958	4,060	3,706	(354)	-9%
Legal Services	8,349	19,551	11,202	134%	88,798	95,919	7,120	8%	335,000	195,419	95,919	(99,500)	-51%
Village Clerk	4,215	2,573	(1,641)	-39%	33,737	19,458	(14,279)	-42%	75,440	43,597	19,458	(24,139)	-55%
Administration	36,751	34,591	(2,161)	-6%	283,702	289,316	5,614	2%	508,850	293,618	289,316	(4,303)	-1%
Employee Relations	21,383	22,254	871	4%	136,558	124,589	(11,969)	-9%	229,612	134,039	124,589	(9,450)	-7%
Financial Management	51,802	56,584	4,782	9%	475,258	453,917	(21,341)	-4%	782,542	464,560	453,917	(10,643)	-2%
Engineering Services	50,115	68,267	18,152	36%	456,100	436,212	(19,888)	-4%	807,009	470,858	436,212	(34,646)	-7%
Community Development	52,100	54,860	2,759	5%	403,954	408,560	4,606	1%	756,865	437,481	408,560	(28,921)	-7%
Management Services	55,014	52,971	(2,043)	-4%	408,662	401,813	(6,850)	-2%	771,830	417,638	401,813	(15,826)	-4%
Police	957,079	892,346	(64,733)	-7%	6,959,697	6,963,253	3,556	0%	12,345,790	7,229,812	6,963,253	(266,559)	-4%
Public Works	168,019	284,699	116,680	69%	1,561,345	1,693,546	132,200	8%	2,882,701	1,708,547	1,693,546	(15,002)	-1%
Municipal Building	25,626	22,154	(3,472)	-14%	166,483	179,722	13,239	8%	345,689	200,334	179,722	(20,612)	-10%
Municipal Garage	(8,778)	6,384	15,162	-173%	34,154	(3,557)	(37,711)	-110%	-	-	(3,557)	(3,557)	100%
Transfers and Agreements	-	71,754	71,754	100%	72,485	146,470	73,985	102%	200,000	141,000	146,470	5,470	4%
Town Center	199	93	(106)	-53%	39,950	30,458	(9,492)	-24%	44,500	40,000	30,458	(9,542)	-24%
Expenditure Totals	1,428,279	1,596,231	167,953	12%	11,222,012	11,332,709	110,697	1%	20,219,690	11,883,240	11,332,709	(550,531)	-5%
Net Increase / (Decrease)	188,864	39,602	(149,263)		582,265	1,385,106	802,841		(135,190)	122,471	1,385,106	1,262,635	

Village of Carol Stream
Water and Sewer Fund Budget Summary
For the Month Ended November 30, 2011

	MONTH				YTD				BUDGET				
	Last Year Nov	Current Year Nov	Monthly Variance		Last Year YTD	Current Year YTD	YTD Variance		Annual Budget	YTD Budget	YTD Actual	Variance	
			\$	%			\$	%				\$	%
REVENUES													
Water Billings	\$ 362,623	\$ 348,176	(14,448)	-4%	\$ 2,605,971	\$ 2,763,376	157,405	6%	\$ 4,331,000	\$ 2,705,122	\$ 2,763,376	58,253	2%
Sewer Billings	200,337	180,955	(19,382)	-10%	1,465,921	1,485,795	19,874	1%	2,307,000	1,440,941	1,485,795	44,854	3%
Penalties/Admin Fees	13,515	9,015	(4,500)	-33%	80,377	83,648	3,271	4%	135,000	78,750	83,648	4,898	6%
Connection/Expansion Fees	14,975	-	(14,975)	-100%	68,329	68,874	545	1%	143,200	83,533	68,874	(14,659)	-18%
Interest Income	3,473	3,259	(214)	-6%	24,855	24,638	(216)	-1%	50,000	29,167	24,638	(4,528)	-16%
Rental Income	16,995	13,410	(3,585)	-21%	89,233	97,833	8,600	10%	163,000	95,083	97,833	2,749	3%
All Other / Miscellaneous	2,699	759	(1,940)	-72%	27,762	45,419	17,657	64%	61,870	26,553	45,419	18,866	71%
Revenue Totals	614,617	555,574	(59,044)	-10%	4,362,447	4,569,583	207,136	5%	7,191,070	4,459,150	4,569,583	110,433	2%
EXPENDITURES													
Salaries & Benefits	74,349	79,422	5,074	7%	601,000	589,698	(11,302)	-2%	1,189,314	686,143	589,698	(96,444)	-14%
Purchase of Water	211,756	240,054	28,298	13%	1,473,868	1,646,767	172,899	12%	2,650,000	1,632,729	1,646,767	14,038	1%
WRC Operating Contract*	535,874	134,928	(400,946)	-75%	933,641	1,155,609	221,968	24%	1,636,465	954,605	1,155,609	201,004	21%
Maintenance & Operating	88,032	75,874	(12,158)	-14%	591,229	557,554	(33,675)	-6%	1,102,220	642,962	557,554	(85,407)	-13%
IEPA Loan P&I	-	-	-	0%	214,325	214,325	-	0%	428,651	214,325	214,325	0	0%
DWC Loan P&I	-	-	-	0%	12,751	12,751	-	0%	12,751	12,751	12,751	0	0%
Capital Outlay	4,552	7,020	2,468	54%	116,941	76,788	(40,154)	-34%	5,068,600	3,350,000	76,788	(3,273,212)	-98%
Expenditure Totals	914,563	537,298	(377,265)	-41%	3,943,757	4,253,493	309,736	8%	12,088,001	7,493,514	4,253,493	(3,240,021)	-43%
Net Increase / (Decrease)	(299,946)	18,276	318,221		418,691	316,090	(102,600)		(4,896,931)	(3,034,364)	316,090	3,350,455	

* The variance in the WRC operating contract is due to some billing lags in the prior fiscal year (7 months in FY11 versus 8 months reflected in FY12 through November).

Village of Carol Stream
Capital Budget Summary
For the Month Ended November 30, 2011

	MONTH				YTD				BUDGET*		
	Last Year Nov	Current Year Nov	Monthly Variance \$ %		Last Year YTD	Current Year YTD	YTD Variance \$ %		Annual Budget	YTD Actual	% of Total
CAPITAL PROJECTS FUND											
REVENUES											
Capital Grants	\$ -	\$ 100,000	100,000	100%	\$ 28,798	\$ 336,207	307,409	1067%	\$ 1,745,000	\$ 336,207	19%
Interest Income	(16,926)	6,180	23,106	-137%	181,929	86,547	(95,381)	-52%	87,000	86,547	99%
All Other / Miscellaneous	26	142,507	142,482	550760%	587	202,864	202,277	34473%	-	202,864	0%
Revenue Totals	(16,900)	248,687	265,588	-1571%	211,314	625,619	414,305	196%	1,832,000	625,619	34%
EXPENDITURES											
Roadway Improvements	14,782	134,714	119,932	811%	213,135	1,600,125	1,386,989	651%	3,747,000	1,600,125	43%
Facility Improvements	-	6,725	6,725	100%	-	111,711	111,711	100%	440,000	111,711	25%
Stormwater Improvements	2,977	4,854	1,877	63%	9,297	574,242	564,945	6077%	151,000	574,242	380%
Miscellaneous	-	1,300	1,300	100%	-	13,451	13,451	100%	-	13,451	0%
Expenditure Totals	17,759	147,593	129,834	731%	222,432	2,299,528	2,077,096	934%	4,338,000	2,299,528	53%
Net Increase / (Decrease)	(34,659)	101,095	135,754	-392%	(11,119)	(1,673,910)	(1,662,791)	14955%	(2,506,000)	(1,673,910)	67%
MFT FUND											
REVENUES											
Motor Fuel Tax Allotments	\$ 71,847	\$ 84,814	12,967	18%	\$ 802,548	\$ 753,361	(49,187)	-6%	\$ 1,048,000	\$ 753,361	72%
Interest Income	439	356	(83)	-19%	3,227	2,476	(752)	-23%	10,000	2,476	25%
Revenue Totals	72,286	85,171	12,884	18%	805,775	755,836	(49,939)	-6%	1,058,000	\$ 755,836	71%
EXPENDITURES											
Street Resurfacing - Capital	-	-	-	0%	1,379,210	-	(1,379,210)	-100%	-	-	0%
Crack Filling	95,202	50,598	(44,604)	-47%	95,202	50,598	(44,604)	-47%	144,000	50,598	35%
Salt	6,067	-	(6,067)	-100%	6,067	-	(6,067)	-100%	257,250	-	0%
Electricity	1,293	2,769	1,477	114%	19,265	20,818	1,552	8%	61,750	20,818	34%
Materials and Supplies	6,868	6,492	(376)	-5%	25,417	31,519	6,102	24%	49,500	31,519	64%
Expenditure Totals	109,429	59,859	(49,570)	-45%	1,525,160	102,934	(1,422,226)	-93%	512,500	102,934	20%
Net Increase / (Decrease)	(37,143)	25,312	62,455	-168%	(719,385)	652,902	1,372,287	-191%	545,500	652,902	120%

* Due to the uncertainty of timing of various capital improvement projects, no YTD budget estimates are shown.

Village of Carol Stream
Other Funds Budget Summary
 For the Month Ended November 30, 2011

GENEVA CROSSING TIF

	MONTH				YTD				BUDGET					
	Last Year	Current Year	Monthly Variance		Last Year	Current Year	YTD Variance		Annual	YTD	YTD	Variance		
	Nov	Nov	\$	%	YTD	YTD	\$	%	Budget	Budget	Actual	\$	%	
REVENUES														
TIF Property Taxes	\$ -	\$ -	-	0%	\$ 353,503	\$ 366,002	12,499	4%	\$ 300,000	\$ 300,000	\$ 366,002	66,002	22%	
Interest Income	48	16	(32)	-67%	387	97	(290)	-75%	500	292	97	(195)	-67%	
Village Contribution	-	71,754	71,754	100%	61,962	146,470	84,508	136%	130,000	120,000	146,470	26,470	22%	
Revenue Totals	48	71,770	71,722	150015%	415,852	512,569	96,717	23%	430,500	420,292	512,569	92,278	22%	
EXPENDITURES														
Principal Retirement	-	-	-	0%	-	-	-	0%	220,000	-	-	-	0%	
Interest Expense	-	-	-	0%	78,330	73,868	(4,463)	-6%	147,735	73,867	73,868	1	0%	
Paying Agent Fees	-	215	215	100%	3,000	3,215	215	7%	3,000	3,000	3,215	215	7%	
Expenditure Totals	-	215	215	100%	81,330	77,082	(4,248)	-5%	370,735	76,867	77,082	215	0%	
Net Increase / (Decrease)	48	71,556	71,508	149567%	334,522	435,487	100,965	30%	59,765	343,425	435,487	92,063	27%	

POLICE PENSION FUND

REVENUES														
Investment Income	\$ (197,157)	\$ 615,938	813,095	-412%	\$ 1,633,319	\$ 1,322,903	(310,416)	-19%	\$ 1,202,500	\$ 701,458	\$ 1,322,903	621,445	89%	
Employee Contributions	38,956	37,840	(1,117)	-3%	296,154	287,395	(8,759)	-3%	518,305	299,022	287,395	(11,627)	-4%	
Village Contribution	104,735	119,548	14,813	14%	733,145	836,836	103,691	14%	1,434,572	836,834	836,836	2	0%	
Other Revenues	-	3,710	3,710	100%	33,763	141,701	107,938	320%	-	-	141,701	141,701	100%	
Revenue Totals	(53,466)	777,035	830,501	-1553%	2,696,381	2,588,835	(107,546)	-4%	3,155,377	1,837,314	2,588,835	751,521	41%	
EXPENDITURES														
Investment and Admin Fees	204	8,023	7,819	3827%	134,004	58,864	(75,140)	-56%	112,130	65,409	58,864	(6,545)	-10%	
Participant Benefit Payments	101,830	112,152	10,323	10%	711,600	741,103	29,504	4%	1,650,000	962,500	741,103	(221,397)	-23%	
Expenditure Totals	102,034	120,176	18,142	18%	845,603	799,968	(45,636)	-5%	1,762,130	1,027,909	799,968	(227,942)	-22%	
Net Increase / (Decrease)	(155,499)	656,860	812,359		1,850,777	1,788,867	(61,910)		1,393,247	809,405	1,788,867	979,462		

Village of Carol Stream
Schedule of Cash and Investment Balances
 November 30, 2011

FUND	CASH	INVESTMENTS	TOTAL CASH & INVESTMENTS	LAST YEAR 11/30/2010
GENERAL FUND	\$ 3,215,394.57	\$ 13,503,888.61	\$ 16,719,283.18	\$ 15,168,392.46
WATER & SEWER FUND	3,108,603.41	14,496,017.16	17,604,620.57	17,748,525.40
CAPITAL PROJECTS FUND	-	19,093,462.40	19,093,462.40	17,898,389.12
MFT FUND	1,615.19	2,308,295.10	2,309,910.29	1,432,060.79
GENEVA CROSSING TIF FUND	1,939,128.17	-	1,939,128.17	1,676,003.85
POLICE PENSION FUND	493,590.44	31,047,212.59	31,540,803.03	28,135,152.66
TOTAL	<u>\$ 8,758,331.78</u>	<u>\$ 80,448,875.86</u>	<u>\$ 89,207,207.64</u>	<u>\$ 82,058,524.28</u>