

Village of Carol Stream

BOARD MEETING

AGENDA

MARCH 6, 2017

7:30 P.M.

All matters on the Agenda may be discussed, amended and acted upon

A. ROLL CALL AND PLEDGE OF ALLEGIANCE:

B. MINUTES:

1. Approval of Minutes of the February 21, 2017 Village Board Meeting.

C. LISTENING POST:

1. Addresses from Audience (3 Minutes).

D. PUBLIC HEARINGS:

E. SELECTION OF CONSENT AGENDA:

If you are here for an item, which is added to the consent agenda and approved, the Village Board has acted favorably on your request.

F. BOARD AND COMMISSION REPORTS:

1. Plan Commission/Zoning Board of Appeals
 - a. #16-2083-AJ Antunes-180 Kehoe Boulevard
Special Use Permit for Outdoor Activities and Operations
RECOMMENDED APPROVAL WITH CONDITIONS 6-0
 - b. #17-0001-Village of Carol Stream-500 N. Gary Avenue
2017 Zoning Map
RECOMMENDED APPROVAL 6-0

G. OLD BUSINESS:

H. STAFF REPORTS AND RECOMMENDATIONS:

1. Emergency Street Light Repair/Replacement Contractor-FY2018. *Staff Recommends awarding a contract extension to H&H Electric Company for emergency street light repair/replacement services for the period of May 1, 2017 through April 30, 2018, pursuant to the provisions of Section 5-8-14(N) of the Carol Stream Code of Ordinances.*

Village of Carol Stream

BOARD MEETING

AGENDA

MARCH 6, 2017

7:30 P.M.

All matters on the Agenda may be discussed, amended and acted upon

2. Signs for the Temporary Village Hall Facility. *Staff recommends authorization to place the order with Western Remac, Inc. for signs for the temporary Village Hall facility in an amount not to exceed \$4,984.60.*
3. Award a Contract for Water Storage Tanks Miscellaneous Concrete and Metal Repairs and Concrete Coating. *Staff recommends awarding a contract to Era Valdivia Contractors, Inc. for Water Storage Tanks Miscellaneous Concrete and Metal Repairs and Concrete Coating in the amount of \$77,210.00.*
4. Award a Contract for Mowing of Rights-of-Way and Village Properties. *Staff recommends awarding a contract to Beary Landscape Management for mowing of rights-of-way and Village properties in the amount of \$72,097.00 for the period of May 1, 2017 through April 30, 2018.*
5. Office Furniture Purchase-Public Works Administrative Offices. *Staff recommends authorization for the purchase and installation of office furniture from Interiors for Business, Inc. under NJPA Contract Number 031715-STI in the amount of \$20,543.85, pursuant to the provisions of Section 5-8-14(L) of the Carol Stream Code of Ordinances.*
6. Award of Contract-Relocation Services. *Staff is recommending rejection of all bids, waiving competitive bidding and awarding the contract to Glen Ellyn Storage Corporation in the amount of \$32,625.00 to move office furniture, equipment and supplies from the Gregory J. Bielawski Municipal Center to temporary Village Hall/Police Station facilities in Carol Stream and Glendale Heights.*

I. ORDINANCES:

1. Ordinance No. ____ Approving a Special Use Permit to allow for Outdoor Activities and Operations in the form of a Vaporizer and Trifecta Equipment in the I Industrial District (Antunes, 180 Kehoe Boulevard). *See Item F-1-a.*

Village of Carol Stream

BOARD MEETING

AGENDA

MARCH 6, 2017

7:30 P.M.

All matters on the Agenda may be discussed, amended and acted upon

J. RESOLUTIONS:

1. Resolution No. ____ Authorizing the Execution of an Intergovernmental Agreement by and between the Village of Carol Stream and the Village of Glendale Heights. *Staff recommends approval of an Intergovernmental Agreement with the Village of Glendale Heights for use of their Holding Facility during the Municipal Center renovation project.*
2. Resolution No. ____ Authorizing the Execution of the Official Zoning Map of the Village of Carol Stream. *See Item F-1-b.*

K. NEW BUSINESS:

1. Raffle License Application-Carol Stream Rotary Club. *The Carol Stream Rotary Club requests approval of a raffle license and waiver of the fee for their annual Chili Open to be held on May 12, 2017.*

L. PAYMENT OF BILLS:

1. Regular Bills: February 22, 2017 through March 6, 2017.
2. Addendum Warrants: February 22, 2017 through March 6, 2017.

M. REPORT OF OFFICERS:

1. Mayor:
2. Trustees:
3. Clerk:

N. EXECUTIVE SESSION:

1. Collective Negotiating Matters.

O. ADJOURNMENT:

LAST ORDINANCE	2017-02-06	LAST RESOLUTION	2925
NEXT ORDINANCE	2017-03-07	NEXT RESOLUTION	2926

**REGULAR MEETING OF THE MAYOR AND BOARD OF TRUSTEES
Carol Stream Fire Protection District, Station No. 28, 365 Kuhn Road,
Carol Stream, DuPage County, IL**

February 21, 2017

Mayor Pro Tem Matt McCarthy called the Regular Meeting of the Board of Trustees to order at 7:30 p.m. and directed Village Clerk Laura Czarnecki to call the roll.

Present: Mayor Pro Tem Matt McCarthy, Trustees David Hennessey, John LaRocca, Rick Gieser and Greg Schwarze

Absent: Mayor Frank Saverino, Sr. and Trustee Mary Frusolone

Also Present: Village Manager Joe Breinig, Assistant Village Manager Bob Mellor, Village Clerk Laura Czarnecki and Village Attorney Jim Rhodes

*All persons physically present at meeting unless noted otherwise

MINUTES:

Trustee Schwarze moved and Trustee Hennessey made the second to approve the Minutes of the February 6, 2017 Special Workshop Meeting of the Village Board. The results of the roll call vote were as follows:

Ayes: 5 Trustees Hennessey, LaRocca, Gieser, Schwarze and McCarthy

Abstain: 0

Absent: 1 Trustee Frusolone

The motion passed.

Trustee Hennessey moved and Trustee Gieser made the second to approve the Minutes of the February 6, 2017 Regular Meeting of the Village Board. The results of the roll call vote were as follows:

Ayes: 5 Trustees Hennessey, LaRocca, Gieser, Schwarze and McCarthy

Abstain: 0

Absent: 1 Trustee Frusolone

The motion passed.

LISTENING POST:

1. Veteran's Spotlight: James Benzin. *Trustee Gieser introduced James Benzin, VFW Commander and Navy retired who described his military life. In the summer of 1967, he barely graduated High School. He enlisted for 6 years in the Navy-4 active/2 reserve. He did his 8 weeks boot camp at Great Lakes Navy Base on December 7th, Pearl Harbor Day. In San Diego Mr. Benzin sailed 2 ½ years on ship. He served as an electrician and 2nd Class Petty Officer and was stationed in support of our Vietnam efforts. He was an E5 Sergeant and reported to the destroyer. In charge of electrical systems on destroyer and became Division Petty Officer. He headed to Vietnam. The ship hit a typhoon halfway to Vietnam and you had to strap yourself in a bunk and when standing. He was very scared the ship was going to capsize and prayed a lot. Mr. Benzin was made Master of Arms, Shore Patrol. Before the Navy Mr. Benzin felt he was a loser in High School and had problems with police. After was a person with a purpose. He went to Elmhurst College on a GI Bill and struggled with learning disabilities, but graduated and became a teacher of students with learning disabilities. For the last 30 years Mr. Benzin has worked to support veterans. Thursday, March 9, VFW is hosting a pasta dinner memorial fund raiser for \$10 which the food is provided by Olive Garden.*
2. Addresses from Audience (3 Minutes). *None.*

PUBLIC HEARINGS:

CONSENT AGENDA:

Trustee LaRocca moved and Trustee Hennessey made the second to establish a Consent Agenda for this meeting. The results of the roll call vote were as follows:

Ayes: 5 Trustees Hennessey, LaRocca, Gieser, Schwarze and McCarthy

Nays: 0

Absent: 1 Trustee Frusolone

The motion passed.

Trustee Hennessey moved and Trustee Gieser made the second to place the following items on the Consent Agenda established for this meeting. The results of the roll call vote were as follows:

Ayes: 5 Trustees Hennessey, LaRocca, Gieser, Schwarze and McCarthy

Nays: 0

Absent: 1 Trustee Frusolone

The motion passed.

1. 2016 Pavement Patching Project-Change Order No. 1, Final Payment and Acceptance.
2. Motion to Extend Street Sweeping Contract for FY18-Hoving Clean Sweep, LLC.
3. Approval to Purchase Two Replacement Squad Cars.
4. Ordinance No. 2017-02-06 Amending Chapter 6, Article 13, Sections 6-13-3, 6-13-4 and 6-13-7 of the Carol Stream Code of Ordinances (Permit and Inspection Fees).
5. Recommendation to refund a portion of fire alarm inspection fees to two applicants in the amounts of \$3,377.44 and \$3,292.80.
6. Raffle License Application-American Cancer Society.
7. Raffle License Application-Carol Stream Chamber of Commerce.
8. Payment of Regular and Addendum Warrant of Bills from February 7, 2017 through February 21, 2017.
9. Treasurer's Report for month ended January 31, 2017.

Trustee Schwarze moved and Trustee LaRocca made the second to approve the Consent Agenda for this meeting by Omnibus Vote. The results of the roll call vote were as follows:

Ayes: 5 Trustees Hennessey, LaRocca, Gieser, Schwarze and McCarthy

Nays: 0

Absent: 1 Trustee Frusolone

The motion passed.

The following are brief descriptions of those items approved on the Consent Agenda for this meeting.

2016 Pavement Patching Project-Change Order No. 1, Final Payment and Acceptance:

The Village Board approved Change Order No. 1, final payment to Schroeder Asphalt Services, Inc. in the amount of \$4,327.46 and acceptance of the 2016 Pavement Patching Project.

Motion to Extend Street Sweeping Contract for FY18-Hoving Clean Sweep, LLC:

The Village Board approved an extension of the contract with Hoving Clean Sweep LLC for Street Sweeping for the period of May 1, 2017 through April 30, 2018, in the amount of \$70,198.00, pursuant to the provisions of Section 5-8-3(B) and subsection 5-8-14(O) of the Carol Stream Code of Ordinances.

Approval to Purchase Two Replacement Squad Cars:

The Village Board approved the purchase of 2 new 2017 Dodge Durangos from Thomas Dodge under the Southwest Conference of Mayors Cooperative Joint Bid for a total cost of \$61,444.

Ordinance No. 2017-02-06 Amending Chapter 6, Article 13, Sections 6-13-3, 6-13-4 and 6-13-7 of the Carol Stream Code of Ordinances (Permit and Inspection Fees):

The Village Board approved revisions to the Fees and Securities for Construction and New Development.

Recommendation to refund a portion of fire alarm inspection fees to two applicants in the amounts of \$3,377.44 and \$3,292.80:

The Village Board approved to refund a portion of fire alarm inspection fees to two applicants in the amounts of \$3,377.44 and \$3,292.80.

Raffle License Application-American Cancer Society:

The Village Board approved a raffle license and waived the fee and Manager's Fidelity Bond for the American Cancer Society for their Relay for Life Bags Tournament to be held at Chrissy's and Flip Flops Tiki Bar.

Raffle License Application-Carol Stream Chamber of Commerce:

The Village Board approved a raffle license and waived the fee for the Carol Stream Chamber of Commerce for their St. Patrick's Day Reverse Raffle to be held on Thursday, March 16, 2017.

Regular Bills and Addendum Warrant of Bills:

The Village Board approved payment of the Regular Bills dated February 21, 2017 in the amount of \$416,468.92. The Village Board approved the payment of

the Addendum Warrant of Bills from February 7, 2017 thru February 21, 2017 in the amount of \$570,240.55.

Treasurer's Report:

Revenue/Expenditure Statements and Balance Sheet for the Month ended January 31, 2017.

Report of Officers:

Trustee LaRocca thanked Jim Benzin for telling his military story and for his service to our country.

Trustee Gieser stated the July 4th Parade Committee will be holding a fundraiser on Saturday, February 25th at Red Apple Pancake House from 6am till 3pm – no flyer needed.

Trustee Hennessey thanked our local press for fairly reporting on Village of Carol Stream events and to the Examiner and Daily Herald who come to our meetings. He has tried to communicate to students to sift out fake news. Trustee Hennessey thanked local and regional media of their tireless work to keep people informed.

Trustee Schwarze thanked Jim Benzin for his service and for his story of his military service. He also thanked the Carol Stream Fire Protection District for allowing the Village of Carol Stream to hold Board meetings at the Fire Station. Please shop Carol Stream.

Village Clerk Czarniecki thanked Jim Benzin as a mother of a son in the military. Military families are so important and to keep them in mind. Please buy a raffle ticket for the bags tournament at Chrissy's on Thursday with the remaining dates at Flip Flops. Flip Flops will donate 15% of all proceeds at every tournament night. Please keep the military and their families in mind.

Village Attorney Rhodes stated the Village Board will be receiving an Ordinance in March on small cell antenna deployment. He also attended an Illinois Local Government lawyer conference, which included round table discussions.

Village Manager Breinig thanked the Carol Stream Fire Protection District for hosting our Village Board meetings. Please let staff know if any adjustments need to be made.

Mayor Pro Tem McCarthy thanked Jim Benzin for taking the time to speak on his military experience and taking charge of Memorial Park. He also thanked the Carol Stream Fire Protection District for hosting our Village Board meetings, which will save us money and time. The Flip Flops-Flood Brothers Relay for Life

Bags Tournament is coming up. The tournament has grown from 64 participants to 80. Thank you Village staff for forming Village Bags Play In Tourney Teams.

At 8:07 p.m. Trustee Hennessey moved and Trustee Gieser made the second to adjourn the meeting. The results of the roll call vote were as follows:

Ayes: 5 Trustees Hennessey, LaRocca, Gieser, Schwarze and McCarthy

Nays: 0

Absent: 1 Trustee Frusolone

The motion passed.

FOR THE BOARD OF TRUSTEES

Matthew McCarthy, Mayor Pro Tem

ATTEST:

Laura Czarnecki, Village Clerk

**Regular Meeting – Plan Commission/Zoning Board of Appeals
Gregory J. Bielawski Municipal Center, DuPage County, Carol Stream, Illinois**

All Matters on the Agenda may be Discussed, Amended and Acted Upon

February 27, 2017

Chairman Frank Parisi called the Regular Meeting of the Combined Plan Commission/Zoning Board of Appeals to order at 7:00 p.m. Chairman Parisi directed Jane Lentino, Community Development Secretary, to call the roll.

The results of the roll call were:

Present: Commissioners David Creighton, Angelo Christopher, Frank Petella, John Meneghini, Charlie Tucek, and Chairman Frank Parisi.

Absent: Commissioner Dee Spink

Also Present: Tom Farace, Planning and Economic Development Manager, Jane Lentino, Community Development Secretary, and a representative from DuPage County Court Reporters.

MINUTES:

Commissioner Creighton moved and Commissioner Petella seconded the motion to approve the minutes of the meeting of January 24, 2017.

The results of the roll call vote were:

Ayes: 6 Commissioners Creighton, Christopher, Petella, Meheghini, Tucek and Chairman Parisi.

Nays: 0

Abstain: 0

Absent: 1 Commissioner Spink

PUBLIC HEARING:

Commissioner Meneghini moved and Commissioner Creighton made the second to open the Public Hearing.

The motion passed by unanimous vote.

Case # 16-2083 – AJ Antunes – 180 Kehoe Blvd

Special Use Permit for Outdoor Activities and Operations

Chairman Parisi swore in the witness, Mr. Sergio Flores, Facilities Manager at AJ Antunes, 180 Kehoe Blvd., Carol Stream, IL, 60188.

Mr. Flores explained that the Special Use request is to upgrade and improve the service of the existing laser equipment. Mr. Flores stated that the upgrade would help cut thicker materials than the current equipment allows, which would keep more work in house as opposed to outsourcing it.

There was no public comment.

Chairman Parisi requested Mr. Farace's comments.

Mr. Farace stated that, as Mr. Flores stated, AJ Antunes is requesting approval of a Special Use permit to allow for outdoor operations in the form of a vaporizer and Trifecta laser assist gas supply system on the west side of the building, just north of their existing 31 foot nitrogen tank which received previous approval. Mr. Farace stated that the Trifecta system would be about eight feet high and would be screened by an existing fence, and that the vaporizer would be about 18 feet high, and that about half of the vaporizer would be screened by the same fence, and the remainder would be screened by a row of existing evergreens on the west side of the property that also screens the loading dock area. Mr. Farace stated that there was one evergreen at the northern most end to be replaced, and that a couple more evergreens be placed to provide better screening for the new equipment.

Mr. Farace stated that the request was similar to other requests from businesses in the industrial area, and that Staff recommends approval with the conditions listed at the end of the Staff report.

Chairman Parisi asked for questions.

Commissioner Petella asked if the equipment fell under the district of the Illinois Fire Marshal as it is a pressurized vessel.

Mr. Flores stated that it does.

There were no other questions.

Commissioner Meneghini moved and Commissioner Petella seconded the motion to approve Special Use Permit for Outdoor Activities and Operations.

The motion passed.

The results of the roll call vote were:

Ayes:	6	Commissioners Creighton, Christopher, Petella, Meneghini, Tucek, Chairman Parisi
Nays:	0	
Abstain:	0	
Absent:	1	Commissioner Spink

This case will go before the Village Board on Monday, March 6, 2017, at 7:30 PM for formal approval.

Chairman Parisi asked for a motion to close Public Hearing.

Commissioner Creighton moved and Commissioner Tucek seconded the motion to close Public Hearing.

The motion was passed unanimously.

PRESENTATION: 17-0001 – Zoning Map Approval

Mr. Farace presented the official updated zoning map, which is reviewed on a yearly basis with deadline of March 31st. Mr. Farace stated that there were three items that were updated in the past year. The first was the subdivision of the Geneva Crossing shopping center at Geneva and Schmale; the second was the rezoning of the AT&T property off North Avenue that was annexed in; and the third was the rezoning upon termination of the Special Use of the Organic Soils landscape waste transfer facility on Kuhn Road. Mr. Farace requested recommendation for approval of the zoning map.

Chairman Parisi asked for questions.

Commissioner Tucek asked for clarification of the rezoning of the Organic Soils landscape waste transfer facility back to R-1.

Mr. Farace presented the area on the map showing the area that was rezoned.

There were no other questions.

Commissioner Petella moved and Commissioner Meneghini seconded the motion to approve the zoning map.

The motion was passed

The results of the roll call vote were:

Ayes:	6	Commissioners Creighton, Christopher, Petella, Meneghini, Tucek, Chairman Parisi
Nays:	0	
Abstain:	0	
Absent:	1	Commissioner Spink

NEW BUSINESS: Mr. Farace reminded the Commission that future meetings would be held on the fourth Monday of the month, in the Boardroom at the Carol Stream Fire Protection District located at 345 Kuhn Road at 7:00pm.

ADJOURNMENT:

At 7:12 pm Commissioner Creighton moved to adjourn the meeting.

The motion passed by unanimous vote.

FOR THE COMBINED BOARD

Recorded and transcribed by,

Jane Lentino
Community Development Secretary

Minutes approved by Plan Commission on this ____ day of _____, 20____.

Chairman

Village of Carol Stream
Interdepartmental Memo

TO: Joseph E. Breinig, Village Manager

FROM: Tom Farace, Planning & Economic Development Manager *TF*

THROUGH: Donald T. Bastian, Community Development Director *DB*

DATE: March 1, 2017

RE: **Agenda Item for the Village Board Meeting of March 6, 2017**
PC/ZBA Case 16-2083, Sergio Flores/Antunes – 180 Kehoe Boulevard, Special Use Permit to Allow for Outdoor Activities and Operations – Vaporizer and Trifecta System in the I Industrial District

Sergio Flores, facilities manager with Antunes, requests approval of a Special Use Permit for outdoor activities and operations in the form of a vaporizer and trifecta laser assist gas supply system. Antunes is a custom solutions provider of countertop cooking equipment and water filtration systems for restaurants, and the additional equipment will aid in meeting additional product demands. There is currently a liquid nitrogen tank on the west side of the building enclosed by a seven foot-tall fence, and the applicant proposes to install the new equipment north of the tank and within the fenced area.

The trifecta equipment will be approximately eight feet tall and will be primarily screened by the existing fence, and the vaporizer will be approximately 18 feet in height and will be screened by both the fence and by a row of evergreen trees along the west side of the property. The applicant has agreed to remove the northernmost evergreen tree which is in declining condition, and install 2-3 additional evergreens for additional screening purposes.

The staff report presenting the request, with supporting documentation, was transmitted to the Village Board with the PC/ZBA packet on February 24, 2017. At its meeting on February 27, 2017, by a vote of 6-0, the PC/ZBA recommended approval of the Special Use Permit subject to the conditions in the February 27, 2017 staff report.

If the Village Board concurs with the PC/ZBA recommendation, they should approve the Special Use Permit for outdoor activities and operations in the form of a vaporizer and trifecta system, subject to the conditions contained within the Ordinance, and adopt the necessary Ordinance.

ec: Sergio Flores, Antunes (via email)

Village of Carol Stream
Interdepartmental Memo

TO: Joseph E. Breinig, Village Manager

FROM: Tom Farace, Planning & Economic Development Manager *TF*

THROUGH: Donald T. Bastian, Community Development Director *DB*

DATE: March 1, 2017

RE: **Agenda Item for the Village Board meeting of March 6, 2017**
PC/ZBA Case 170001, Village of Carol Stream, Official 2017 Zoning Map

As required by state statute, the Village must publish a current zoning map by March 31 of each year. For your review and reference, staff has prepared the attached Village of Carol Stream Official Zoning Map for 2017. The proposed 2017 map includes all zoning map amendments approved by the Village Board between January 1, 2016, and December 31, 2016. Below is information regarding the changes that have been incorporated into the 2017 Zoning Map.

- 1. An Amendment to a Planned Unit Development and Final Plat of Subdivision for 560 S. Schmale Road** – T Geneva Crossing IL LLC (Geneva Crossing Shopping Center) was granted approval of a four lot subdivision and a PUD amendment (PINs 05-04-304-074, 05-04-304-076, 05-04-304-077, and 05-04-304-078).
- 2. Annexation and Zoning for 27W245 North Avenue** – The AT&T Mobile Tel property was annexed into the Village, and upon annexation, was rezoned to B-3 Service District. In addition, front building setback, outdoor storage, and fence code variations were granted (PINs 01-36-400-024 and 01-36-400-025).
- 3. Zoning Map Amendment and Special Use Termination for 295 N. Kuhn Road** – The Special Use Permit for the proposed landscape waste transfer facility for Organic Soils was terminated and the property was rezoned from B-3 Service District back to R-1 One-Family Residence District (No separate PIN was established since the plat of subdivision was never approved nor recorded).

The staff report and draft zoning map were transmitted to the Village Board with the Plan Commission/Zoning Board of Appeals (PC/ZBA) packet on February 24, 2017. At their February 27, 2017, meeting, the PC/ZBA recommended approval of the Official 2017 Zoning Map by a vote of 6-0.

If the Village Board concurs with the PC/ZBA recommendation, they should approve the Official 2017 Zoning Map and adopt the necessary Resolution.

Village of Carol Stream
Interdepartmental Memo

TO: Joe Breinig, Village Manager

FROM: Philip J. Modaff, Director of Public Works 

DATE: February 23, 2017

RE: Emergency Street Light Repair/Replacement Contractor – FY2018

In March 2016, Public Works opened bids for a contractor to perform emergency street light repair services. This contract provides emergency response services beyond in-house capability, typically in situations where a street light pole has been knocked down that requires complete replacement. The contract is intended to have one contractor available for quick response with pre-determined labor and equipment rates. No guarantee of work is included in the contract due to the unpredictable need for services.

The Village Board awarded a contract to H&H Electric Company for the current fiscal year. (Attached is a copy of the staff memo and bid tabulation from the March 2016 bid process for reference). Their bid included an option for a one-year extension at the Village's discretion with an increase of up to four-percent (4%). Staff has recently conferred with H&H and they have indicated their desire to provide the services *at no increase* for the period May 1, 2017 through April 30, 2018. (A copy of an e-mail from H&H Electric Company detailing their offer is attached for reference).

Staff recommends the Board approve a Motion awarding a contract extension to H&H Electric Company for emergency street light repair/replacement services for the period of May 1, 2017 through April 30, 2018, pursuant to the provisions of Section 5-8-14(N) of the Carol Stream Code of Ordinances.

Attachments

Village of Carol Stream
Interdepartmental Memo

TO: Joe Breinig, Village Manager

FROM: Philip J. Modaff, Director of Public Works
Michele Lopez, Public Works Office Manager

DATE: May 12, 2016

RE: Motion to Award a Contractor for Emergency Street Light Repair Services
– H&H Electric Company

In April 2016 Public Works solicited bids for annual emergency street light repair services. This contract allows Public Works to have a contractor available to replace or repair damaged streetlights (typically from vehicle knockdowns). The scope of the work covered by this contract is typically beyond the capabilities of in-house staff.

Bid packets were sent to eight (8) interested contractors with four (4) companies returning bids. Public Works cannot predict exactly how many hours will be needed for each equipment and labor type, so bidders were instructed that we would apply the hourly rates submitted to an estimated number of hours for each cost type (see full bid tabulation attached). For bid evaluation purposes Public Works solicited hourly rates from vendors based upon our own historical usage of this type of emergency service. However, no work is guaranteed under the contract.

H&H Electric Company provided the lowest combined rates for the various labor and equipment types listed on the bid form. H&H has also satisfactorily provided these services to the Village for the past four years. A copy of the bid submitted by H&H is attached.

Therefore, it is recommended that the Village Board approve a motion awarding a contract to H&H Electric Company for Emergency Street Light Repair Services for the period June 1, 2016, through April 30, 2017.

Attachments

Emergency Street Light Repairs - Bid Tabulation

Labor Types	Utility Dynamics		
	Units	Hourly	Extended
Foreman	40	\$109.00	\$ 4,360.00
Lineman	10	\$98.00	\$ 980.00
Operator	10	\$90.00	\$ 900.00
Groundman	40	\$81.00	\$ 3,240.00
TOTAL:			\$ 9,480.00

Labor Types	H&H		
	Units	Hourly	Extended
Foreman	40	\$ 104.20	\$ 4,168.00
Lineman	10	\$ 74.40	\$ 744.00
Operator	10	\$ 8.20	\$ 82.00
Groundman	40	\$ 62.00	\$ 2,480.00
TOTAL:			\$ 7,474.00

Labor Types	Meade		
	Units	Hourly	Extended
Foreman	40	\$ 109.94	\$ 4,397.60
Lineman	10	\$ 97.63	\$ 976.30
Operator	10	\$ 25.00	\$ 250.00
Groundman	40	\$ 67.42	\$ 2,696.80
TOTAL:			\$ 8,320.70

Labor Types	Omega		
	Units	Hourly	Extended
Foreman	40	\$ 99.00	\$ 3,960.00
Lineman	10	\$ 90.00	\$ 900.00
Operator	10	\$ 65.00	\$ 650.00
Groundman	40	\$ 65.00	\$ 2,600.00
TOTAL:			\$ 8,110.00

Equipment Types			
Service Truck	5	\$ 20.00	\$ 100.00
Line Truck	40	\$ 40.00	\$ 1,600.00
Bucket Truck	40	\$ 36.00	\$ 1,440.00
Trencher	5	\$ 20.00	\$ 100.00
Backhoe	5	\$ 20.00	\$ 100.00
D-bore Machine	5	\$ 120.00	\$ 600.00
Mini-excavator	5	\$ 20.00	\$ 100.00
TOTAL:			\$ 4,040.00

Equipment Types			
Service Truck	5	\$ 1.00	\$ 5.00
Line Truck	40	\$ 1.00	\$ 40.00
Bucket Truck	40	\$ 45.00	\$ 1,800.00
Trencher	5	\$ 1.00	\$ 5.00
Backhoe	5	\$ 1.00	\$ 5.00
D-bore Machine	5	\$ 45.00	\$ 225.00
Mini-excavator	5	\$ 10.00	\$ 50.00
TOTAL:			\$ 2,130.00

Equipment Types			
Service Truck	5	\$ 29.00	\$ 145.00
Line Truck	40	\$ 40.00	\$ 1,600.00
Bucket Truck	40	\$ 40.00	\$ 1,600.00
Trencher	5	\$ 1.00	\$ 5.00
Backhoe	5	\$ 1.00	\$ 5.00
D-bore Machine	5	\$ 125.00	\$ 625.00
Mini-excavator	5	\$ 25.00	\$ 125.00
TOTAL:			\$ 4,105.00

Equipment Types			
Service Truck	5	\$ 15.00	\$ 75.00
Line Truck	40	\$ 25.00	\$ 1,000.00
Bucket Truck	40	\$ 20.00	\$ 800.00
Trencher	5	\$ 50.00	\$ 250.00
Backhoe	5	\$ 50.00	\$ 250.00
D-bore Machine	5	\$ 200.00	\$ 1,000.00
Mini-excavator	5	\$ 45.00	\$ 225.00
TOTAL:			\$ 3,600.00

GRAND TOTAL:			\$ 13,520.00
---------------------	--	--	--------------

GRAND TOTAL:			\$ 9,604.00
---------------------	--	--	-------------

GRAND TOTAL:			\$ 12,425.70
---------------------	--	--	--------------

GRAND TOTAL:			\$ 11,710.00
---------------------	--	--	--------------

BID FORM (page 1 of 2)

The bidder in submitting this bid hereby agrees to comply with all provisions and requirements of the specifications and contract documents attached hereto. The undersigned ("Contractor") agrees to furnish to the Village of Carol Stream, an Illinois Municipal Corporation hereinafter referred to as the "Village", **Emergency Streetlight Repair Services** for the period June 1, 2016 through April 30, 2017, at the rates as proposed below:

Labor Types	Units (Hours)	Hourly Rate	Extended
Foreman	40	\$ 104.20	\$ 4,168.00
Lineman	10	\$ 74.40	\$ 744.00
Operator	10	\$ 8.20	\$ 82.00
Groundman	40	\$ 62.00	\$ 2,480.00
Labor Total:			\$ 7,474.00

Equipment Types	Units (Hours)	Hourly Rate	Extended
Service Truck	5	\$ 1.00	\$ 5.00
Line Truck	40	\$ 1.00	\$ 40.00
Bucket Truck	40	\$ 45.00	\$ 1,800.00
Trencher	5	\$ 1.00	\$ 5.00
Backhoe	5	\$ 1.00	\$ 5.00
D-bore Machine	5	\$ 45.00	\$ 225.00
Mini-Excavator	5	\$ 10.00	\$ 50.00
Equipment Total:			\$ 2,130.00

GRAND TOTAL (total of Labor PLUS Equipment): \$ 9,604.00

BID FORM (page 2 of 2)

ONE-YEAR EXTENSION

At its sole discretion, the Village may extend the contract to cover a one-year additional contract period. Rates for services listed for the period **June 1, 2016 through April 30, 2017**, will not increase more than 4 % for a one-year additional contract period (**May 1, 2017 through April 30, 2018**).

Name of Contractor: H&H ELECTRIC CO.

Address: 2830 COMMERCE STREET

FRANKLIN PARK, ILLINOIS 60131

Telephone No: 708-453-2222 Date: 05/04/2016

Contact Person: LOUIE VENEZIANO Date: 05/04/2016

Authorized Signature:  Title: PRESIDENT
LOUIE VENEZIANO

**BIDS MUST BE RECEIVED IN THE PUBLIC WORKS
DEPARTMENT – 124 Gerzevske Lane, Carol Stream, IL –
NO LATER THAN 10:00 AM, on Thursday, May 5, 2016**

From: Louie Veneziano [<mailto:louie.veneziano@hh-electric.com>]
Sent: Saturday, January 14, 2017 11:51 AM
To: Michele Lopez <mlopez@carolstream.org>
Cc: Ron Roehn <rroehn@carolstream.org>
Subject: Emergency Streetlight Repair Services (C-44SL-Carol Stream)

Michele:

We would be willing to continue work at the same rates for the May 1, 2017 through April 30, 2018 so that the contract can be extended without solicitation of new RFP's for your 2018 fiscal year.

Please confirm that this is acceptable.

Thank you,

Louie Veneziano



2830 Commerce Street
Franklin Park, Illinois 60131-2927
(708)-453-2222 **PHONE**
(708)-453-2851 **FAX**
www.hh-electric.com

LIGHTING THE WAY SINCE 1944

 Please do not print this e-mail unless absolutely necessary.

From: Michele Lopez [<mailto:mlopez@carolstream.org>]
Sent: Tuesday, January 03, 2017 1:31 PM
To: Louie Veneziano <louie.veneziano@hh-electric.com>
Cc: Ron Roehn <rroehn@carolstream.org>
Subject: Emergency Streetlight Repair Services

Good Afternoon Louie:

Happy New Year and I hope my email finds you doing well. We are looking at some of our contracts for the coming fiscal year and wanted to touch base on the Emergency Streetlight Repair Services. Included in the bid form you submitted last year, there was a one-year extension option which would cover May 1, 2017 through April 30, 2018. Before possibly soliciting RFP's for our 2018 fiscal year I wanted to see what H&H would be willing to offer.

Thank you and I look forward to hearing from you soon.

Michele Lopez

Village of Carol Stream
Public Work Department
124 Gerzevske Lane
Carol Stream, IL 60188
(630) 871-6261

AGENDA ITEM
H-2 3-6-17

Village of Carol Stream
Interdepartmental Memo

TO: Joseph E. Breinig, Village Manager

FROM: Donald T. Bastian, Community Development Director *DB*

DATE: March 1, 2017

RE: **Agenda Item for the Village Board Meeting of March 6, 2017 – Request for Village Board Authorization to Purchase Signs for the Temporary Village Hall Facility**

As you know, most Municipal Center staff at 500 N. Gary Avenue will be moving into the temporary Village Hall facility at 505 E. North Avenue in April, in advance of the renovation and expansion of the Municipal Center. Renovation work is underway at 505 E. North Avenue to prepare the building for our use.

As part of the effort to notify our customers and the general public about the location of our temporary Village Hall, staff has met several times to discuss the content, style and locations for signage for the temporary facility. We have also coordinated with applicable property owners and representatives from IDOT and DuDOT for signs that would be installed within rights-of-way. The table below lists the various signs that staff is recommending for installation.

For your information, attached to this memo are an aerial photo showing the proposed location of each sign, a rendering of each sign and cost proposals. Staff has been working with a Woodridge-based sign company, Western Remac, which Public Works recently used to make the new wall sign installed on the Public Works administration building at 124 Gerzevske Drive.

Sign Type	Sign Location	Sign Dimensions
Wall Sign (A)	South wall of 505 building facing North Avenue	8' by 44' or 352 s.f.
Directional Sign (B) (two-sided)	Immediately south of the Schmale Road access drive to WDSRA	4' by 6' or 24 s.f.
Directional Sign (C)	East side of Schmale Road right-of-way for northbound Schmale Road motorists	2' by 2.5' or 5 s.f.
Directional Sign (D)	West side of Schmale Road right-of-way for southbound Schmale Road motorists	2' by 2.5' or 5 s.f.
Directional Sign (E)	North side of North Avenue right-of-way for westbound North Avenue motorists	2' by 2.5' or 5 s.f.
Directional Signs (F)	On-site along the east-west access drive into the property from Schmale Road	1.5' by 1.5' or 2.25 s.f.

Following is additional detail about each proposed sign:

Sign A – A 352 s.f. wall sign that would be installed on the south wall of the 505 E. North Avenue building. The sign would consist of eleven 4' by 8' panels.

Sign B – A 24 s.f., two-sided sign that will be installed immediately south of the access driveway into the Western DuPage Special Recreation Association (WDSRA) property off of Schmale Road. The sign, which would be installed on WDSRA property, would alert both north and southbound Schmale Road motorists of the rear driveway entrance to the temporary Village Hall facility. (A cross access easement exists to allow vehicular access to 505 E. North Avenue.)

Signs C and D – Sign C would be installed in the right-of-way along the east side of Schmale Road to alert northbound motorists of the approaching access drive to the temporary facility, and Sign D would be installed in the right-of-way along the west side of Schmale Road to alert southbound motorists of the approaching access drive to the temporary facility. DuDOT has approved installation of the signs within the Schmale Road right-of-way.

Sign E – Sign E would be installed in the right-of-way along the north side of North Avenue, in front of the 505 E. North Avenue building, to alert westbound motorists of the approaching driveway into the property. IDOT has approved installation of the sign within the North Avenue right-of-way.

Sign F – These two signs will be located along the rear, east-west driveway on the 505 E. North Avenue property, to direct motorists using the Schmale Road access to the main entrance to the temporary Village Hall.

Signs B, C, D, E and F would be reflective signs consistent with signs installed along public roadways. The building wall sign is neither reflective nor proposed to be illuminated, but we will revisit the need for illumination after installation.

Signs C, D, E and F have been paid for and received. These signs were paid for from the Public Works Department's Street Division Street Signs account.

As shown on the proposal attached to the wall sign (Sign A) rendering, the wall sign would cost \$2,270 to fabricate, \$2,165 to install, and \$1,520 to remove. The decision to remove or repurpose the wall sign will be made after consultation with the building owner near the end of our lease. As shown on the proposal for Sign B, to be installed just south of the WDSRA driveway, the sign will cost \$549.60 to fabricate. Public Works staff will provide the mounting hardware and install this sign. Signs A and B will be budgeted from the Municipal Building operating fund.

RECOMMENDATION

Staff is seeking Village Board authorization to place the order with Western Remac, Inc. for Signs A and B, in the amount of \$4,984.60 as shown on the attached exhibits and proposals. It is recommended that the Village Board authorize staff, by motion, to order the signs at the March 6, 2017, meeting.

TEMPORARY VILLAGE HALL FACILITY – PROPOSED SIGNAGE EXHIBIT

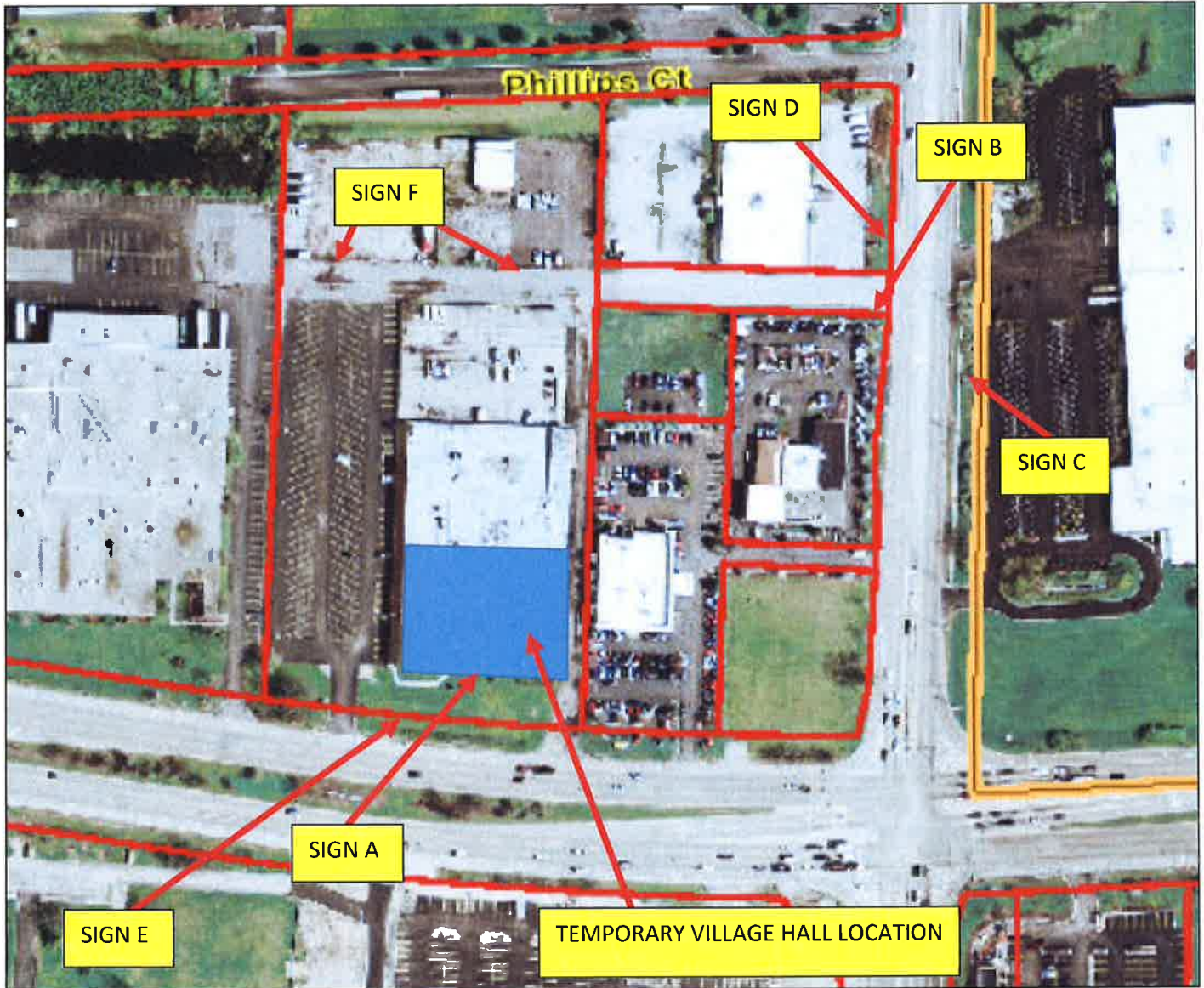



1700 Internationale Pkwy. (630) 674-7770
Woodridge, IL 60517 fax: (630) 974-9080

PROJECT:	DATE: 1/25/2017
CUSTOMER: Village of Carol Stream	CONTACT:
SALESPERSON: Serge Ruffolo	PHONE: FAX:
PROD. FILE NAME: village hall police.fs	DESIGNER: Donna
CUSTOMER APPROVAL SIGNATURE:	SCALE: 0.008

PROCESS/MATERIALS
 CUT VINYL
 EXTRUDED PANEL
 ROUTED
 DIGITAL
 SILKSCREEN
 WRI DURAGRAPHICS
 OTHER
 color names:
 PMS 280 Blue
 7725-12 Black

CUT VINYL:
 n/r e/g e/c
 egg vl hip
 d/g3 d/g vip
 1st or 2nd surf: 1st
 substrate: White dibond
 ROUTED:
 substrate:
 de-mount:
 finish:
 mounting:

DIGITAL PRINT:
 media:
 overlam:
 substrate:
 1st or 2nd surf:
 R1, R2, R3
 SILKSCREEN
 media:
 ink:
 substrate:
 ADA SIGNAGE:
 wri-duragrapic:
 photopolymer:
 other
 fonts:
 Charne, Georgia Bd
 radius:
 margin:
 border:
 mounting
 instructions:

44 ft

8 ft

CS Village of Carol Stream
Village Hall - Police Department



200 ft

115 ft

24 ft

SIGN B



Your Complete Sign Solution Provider

1710 Internationale Pkwy. (630) 972-7770
Woodridge, IL 60517 Fax (630) 972-9680

PROJECT:	DATE: 2/14/2017	
CUSTOMER: Village of Carol Stream	CONTACT:	
SALESPERSON: Serge Ruffolo	PHONE:	FAX:
FILE NAME: carol stream directional.fs	DESIGNER: Donna	
CUSTOMER APPROVAL SIGNATURE:		



Sign 1, South Side
Digital Print on HIP 3930 White on .080 Alum



Sign 2, North Side
Digital Print on HIP 3930 White on .080 Alum



Your Complete Sign Solution Provider
 1740 Internationale Pkwy. (630) 972-7770
 Woodridge, IL 60517 fax (630) 972-9680

PROJECT:	DATE: 2/9/2017	
CUSTOMER: Village of Carol Stream	CONTACT: Jason Pauling	
SALESPERSON: Serge Ruffolo	PHONE:	FAX:
FILE NAME: village hall.fs	DESIGNER: Donna Sassano	
CUSTOMER APPROVAL SIGNATURE:		

SIGN F



SIGN C

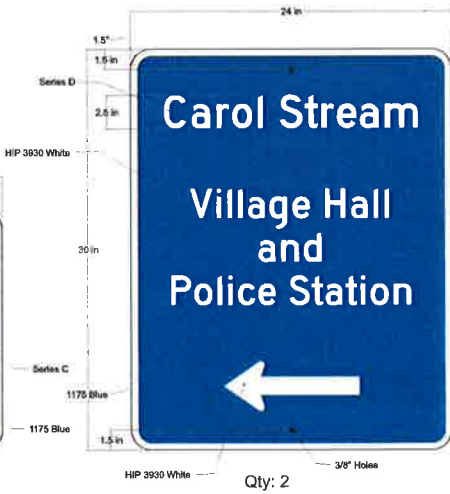

SIGN D

SIGN E





1740 Internationale Parkway
 Woodridge IL 60517-4994
 (630) 972-7770 Fax (630) 972-9680

Proposal
S78912

2/9/2017

Page 1 of 1

SIGN A

Sold to: Village of Carol Stream
 500 North Gary Avenue

Ship to: Serge to coor. w/Don Bastian
 Temp Carol Stream Village Hall
 505 E. North Avenue
 Carol Stream IL 60188

Carol Stream IL 60188--189

Purchase Order #	Ship Via	Terms	Sales Rep
	WRI Install	Net 30	17-102

Quantity	Unit	Description	Unit Price	Extended Price
1.00	SET	FURNISH: 8'h x 44'w (eleven: 4'w x 8'h sections), "Village of Carol Stream Village Hall - Police Department" temp. Building I.D. signage, Blue & Black graphics on 3mm Dibond panels (per attached drawing).	2,270.00	2,270.00
1.00	LS	INSTALL: The above 8'h x 44'w (eleven: 4'w x 8'h sections), "Village of Carol Stream Village Hall - Police Department" temp. Building I.D. signage, UNION LABOR, daytime rates. The Dibond panels to be mounted to the brick building using TapCon fasteners (per attached drawing). *Plywood to be laid on grass (provided by WRi), so lift vehicle can drive up to sign location (on South side of the building, facing North Avenue) and limit any damage.	2,165.00	2,165.00
1.00	LS	REMOVAL: The above 8'h x 44'w "Village of Carol Stream Village Hall - Police Department" temp. Building I.D. signage to be removed & disposed of; UNION LABOR, daytime rates. *Once TapCon fasteners are removed from brick building, holes to be filled with clear silicone. *Plywood to be laid on grass (provided by WRi), so lift vehicle can drive up to sign location (on South side of the building, facing North Avenue) and limit any damage.	1,520.00	1,520.00

WRi E#170209-01

Subtotal	5,955.00
Tax	0.00
Proposal Total	5,955.00

Permit and Additional Insuranced Fees not included in our proposal.
 Installation to be Union Labor at Standard Rates.
 All orders F.O.B. Woodridge unless otherwise noted.
 Applicable freight taxes will be added.

Customer Signature: _____ Date: _____ P.O. # _____



1740 Internationale Parkway
 Woodridge IL 60517-4994
 (630) 972-7770 Fax (630) 972-9680

Proposal
S78953
 2/15/2017
Page 1 of 1

SIGN B

Sold to: Village of Carol Stream
 500 North Gary Avenue

Ship to: Call Don Bastian for p.u.
 630-871-6233

Carol Stream IL 60188-189

Purchase Order #	Ship Via	Terms	Sales Rep
	Customer Pick Up	Prepaid	17-102

Quantity	Unit	Description	Unit Price	Extended Price
2.00	EA	FURNISH: 4'h x 6'w, "Village of Carol Stream VILLAGE OFFICES / POLICE DEPARTMENT..." with directional arrows, one (1) each layout, 3M Brand HIP reflective on .080 aluminum (per the attached drawing).	274.80	549.60
2.00	EA	FURNISH: 2" x 2" x 10' galv. Telespar post	32.50	65.00
2.00	EA	FURNISH: 2 1/4" x 2 1/4" x 5' galv. Telespar sleeve (for pounding into ground to support 2" x 2" telespar post)	26.85	53.70

Subtotal 668.30
Tax 0.00
Proposal Total 668.30

Permit and Additional Insuranced Fees not included in our proposal.
 Installation to be Union Labor at Standard Rates.
 All orders F.O.B. Woodridge unless otherwise noted.
 Applicable freight taxes will be added.

Customer Signature: _____ Date: _____ P.O. # _____

Village of Carol Stream
Interdepartmental Memo

TO: Joe Breinig, Village Manager

FROM: Philip J. Modaff, Director of Public Works
Ron Roehn, Superintendent of Operations 

DATE: March 3, 2017

RE: Recommendation to Award a Contract for Water Storage Tanks Miscellaneous Concrete and Metal Repairs and Concrete Coating – Era Valdivia Contractors, Inc.

The FY17 budget contains \$100,000 for inspection of all five water storage tanks and the first phase of needed repairs and maintenance. Dixon Engineering & Inspection Services was hired to conduct the inspections, recommend a multi-year repair and maintenance program¹, prepare plans and specifications for the first year and assist in evaluating bids.

Four bids were submitted on February 27, 2017, at the Public Works Center. However, one of the bids was disqualified because it arrived after the published bid-opening time. Bids results are as follows:

<u>COMPANY</u>	<u>BID AMOUNT</u>
Era Valdivia Contractors	\$ 77,210.00
Seven Brothers	\$ 84,400.00
Tecorp	\$116,800.00

Era Valdivia was pre-qualified by Dixon Engineering and has successfully completed many similar projects, including four of the five standpipe rehabilitation projects for the DuPage Water Commission. Bid documents submitted by Era Valdivia have been checked and verified to be in compliance with bid requirements. A recommendation letter from Dixon Engineering is attached.

Staff recommends that the Mayor and Board approve a Motion awarding a contract to Era Valdivia Contractors, Inc., for Water Storage Tanks Miscellaneous Concrete and Metal Repairs and Concrete Coating, in the amount of \$77,210.00.

Attachments

¹ Staff has prepared a multi-year budget proposal totaling about \$850,000 to complete other recommended work over the next five years, including painting of two of the three elevated tanks.



DIXON

**ENGINEERING & INSPECTION SERVICES
FOR THE COATING INDUSTRY**

5307 South 92nd Street
Suite 125
Hales Corners, WI 53130
Telephone: (630) 220-1410

February 28, 2017

Mr. Ron Roehn
Superintendent of Operations
Carol Stream Public Works
124 Gerzevske Lane
Carol Stream, IL. 60188

Re: Five Water Tower Rehabilitation Project – Recommendation for Award

Dear Ron:

Dixon Engineering, Inc. has reviewed the bids submitted for the five tower rehabilitation project and recommends the award to the low bidder, Era Valdivia Contractors, Inc. of Chicago in the amount of \$77,210.00. Bidding was competitive with four (4) bids received. One bid was disqualified as it came in after the bid opening time.

Era Valdivia contractors is a prequalified contractor with Dixon Engineering for this scope of work and has successfully completed many similar projects. They have currently completed 4 of the 5 standpipe rehabilitation project for DuPage Water Commission in the last two years, and will complete the last standpipe for them this year.

Enclosed for your review and action are three copies of the notice of award. After approval, please sign and forward all three copies to Era Valdivia for signature. Instruct the contractor to return one copy to you, forward a copy to our office, and retain a copy for his files. Also, please ask the contractor to forward to our office the required bonds and certificate(s) of insurance for inclusion into the contract documents.

If you have any questions regarding our recommendation, please don't hesitate to contact me at (630) 220-1410.

FOR DIXON ENGINEERING, INC.,

Brad Schotanus
Illinois Division Manager

**Members: Society of Protective Coatings • American Water Works Association
Consulting Engineers Council**

SECTION 00 43 73
SCHEDULE of VALUES

1.01 PART 1

A. Bidder agrees to perform all work in the following sections as described in the Contract Documents, including all labor and material for the following Schedule of Values – Section 03 01 00.01:

1. <u>CRACK REPAIR – FULLERTON TANK</u>	<u>\$ 100.⁰⁰ /LIN. FT. X 5 LIN. FT. =</u>	<u>\$ 500.⁰⁰</u>
2. <u>SPALL REPAIR – FULLERTON TANK</u>	<u>\$ 600.⁰⁰ /CUBIC FT. X 2 CUBIC FT. =</u>	<u>\$ 1,200.⁰⁰</u>
3. <u>GROUT REPAIR- FULLERTON TANK</u>	<u>\$ 85.⁰⁰ /LIN. FT. X 6 LIN. FT. =</u>	<u>\$ 510.⁰⁰</u>
4. <u>GROUT REPAIR – GERZEVSKE TANK</u>	<u>\$ 100.⁰⁰ /LIN. FT. X 10 LIN. FT. =</u>	<u>\$ 1,000.⁰⁰</u>
5. <u>CRACK REPAIR – GERZEVSKE RESERVOIR</u>	<u>\$ 75.⁰⁰ /LIN. FT. X 200 LIN. FT. =</u>	<u>\$ 15,000.⁰⁰</u>
6. <u>SPALL REPAIR – GERZEVSKE RESERVOIR</u>	<u>\$ 100.⁰⁰ /SPALL X 75 SPALLS =</u>	<u>\$ 7,500.⁰⁰</u>
7. <u>CRACK REPAIR – KUHN RESERVOIR</u>	<u>\$ 75.⁰⁰ /LIN. FT. X 200 LIN. FT. =</u>	<u>\$ 15,000.⁰⁰</u>
8. <u>SPALL REPAIR – KUHN RESERVOIR</u>	<u>\$ 100.⁰⁰ /SPALL X 75 SPALLS =</u>	<u>\$ 7,500.⁰⁰</u>

TOTAL PRICE SECTION 03 01 00.01 INCLUDING #1 THROUGH #8:
\$ 48,210.⁰⁰

B. Bidder agrees to perform all work in the following sections as described in the Contract Documents, including all labor and material for the following Schedule of Values – Section 05 00 00:

1. OVERFLOW FLAP GATE – LIES TANK

\$ 5,000.⁰⁰
2. OVERFLOW PIPE BRACE REPAIR – FULLERTON TANK

\$ 7,000.⁰⁰
3. ACCESS TUBE GAP COVER – GERZEVSKE TANK

\$ 7,000.⁰⁰

TOTAL PRICE SECTION 05 00 00 INCLUDING #1 THROUGH #3:

\$ 19,000.⁰⁰

C. Bidder agrees to perform all work in the following sections as described in the Contract Documents, including all labor and material for the following Schedule of Values – Section 09 97 23:

1. FOUNDATION COATING – FULLERTON TANK

\$ 5,000.⁰⁰
2. FOUNDATION COATING – GERZEVSKE TANK

\$ 5,000.⁰⁰

TOTAL PRICE SECTION 09 97 13 INCLUDING #1 THROUGH #2:

\$ 10,000.⁰⁰

TOTAL PRICE SECTION 03 01 00.01, 05 00 00 and 09 97 23:

SECTION 03 01 00.01:	\$ 48,210. ⁰⁰
SECTION 05 00 00:	\$ 19,000. ⁰⁰
SECTION 09 97 23:	\$ 10,000. ⁰⁰
PROJECT TOTAL:	\$ 77,210. ⁰⁰

1.02 TOTALS

A. Total Base Bid is to match total Base Bid price supplied in Bid/Agreement form.

1.03 BID BOND

A. Bid Bond shall be based on 10% of the total.

1.04 WEIGHTED BIDS

A. Bidder/contractor is advised that, if in the opinion of the owner or engineer, if the Schedule of Values is not an accurate reflection of cost of items, the owner will adjust individual costs to more balance costs. Total will not be changed.

NON-COLLUSION AFFIDAVIT

The Bidder is required to execute and submit with his Bid, the Non-Collusion Affidavit:

State of: Illinois

County of: Cook

Bid Identification: Village of Carol Stream (5 Tanks)

CONTRACTOR Era Vaddivira Contr. Inc., being first duly sworn, deposes and says that he is (sole owner, a partner, president, secretary, etc.) of the party making the foregoing BID; that such BID is not made in the interest of or on behalf of any undisclosed person, partnership, company, association, organization, or corporation; that such BID is genuine and not collusive or sham; that said BIDDER has not directly or indirectly induced or solicited any other BIDDER to put in a false or sham BID, and has not directly or indirectly colluded, conspired, connived, or agreed with any BIDDER or anyone else to put in a sham BID, or that anyone shall refrain from bidding; that said BIDDER has not in any manner, directly or indirectly, sought by agreement, communication or conference with anyone to fix the BID price of said BIDDER or of any other BIDDER, or to fix any overhead, profit, or cost element of such BID price, or that of any other BIDDER, or to secure any advantage against the OWNER awarding the CONTRACT or anyone interested in the proposed CONTRACT; that all statements contained in such BID are true; and, further, that said BIDDER has not, directly or indirectly, submitted his BID price or any breakdown thereof, or the contents thereof, of divulged information or data relative thereto, or paid and will not pay any fee in connection therewith, to any corporation, partnership, company, association, organization, BID depository, or to any member or agent thereof, or to any other individual except to such person or persons as have a partnership or other financial interest with said BIDDER in his general business.

Signed:

[Signature]

Subscribed and sworn to before me this the day of:

February 27, 2017

Seal of Notary:

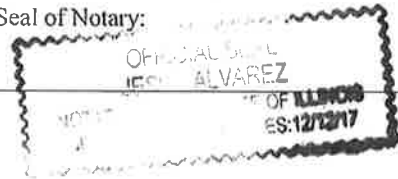

CONTRACTOR CERTIFICATION

Jose G. Valdivia, being first duly sworn on oath, deposes and states that all statements herein made are made on behalf of Contractor, that this deponent is authorized to make them, and that the statements contained herein are true and correct.

Contractor deposes, states, and certifies that Contractor is not barred from bidding and/or contracting with a unit of state or local government as a result of (i) a delinquency in the payment of any tax administered by the Illinois Department of Revenue unless Contractor is contesting in accordance with the procedures established by the appropriate Revenue Act, its liability for the tax or the amount of tax, as set forth in 65 ILCS 5/11-42.1-1; or (ii) a violation of 720 ILCS 5/33E-1 et seq.

Dated this 27th day of February, 2017

Attest/Witness:
By: [Signature]

By: J. G. Valdivia

Title: Pg. Mgr.

Title: President

Subscribed and sworn to before me this the 27th day of February, 2017

My Commission Expires:
12/12/2017

[Signature]

Notary Public

Seal



CERTIFICATION FOR CONTRACT

The undersigned, as a duly authorized representative of the Contractor, hereby certified to the (Client) Village of Carol Stream, Illinois, that the Contractor is fully aware of and able to comply with all Local, State, and Federal Safety Laws and Regulations applicable for the construction of the Project known as (Project):

5 Tanks - Misc. Repair

Jose G. Valdivia

Name

Era-Valdivia Contractors Inc.

Company

2/27/17

Date

CERTIFICATE OF COMPLIANCE WITH SECTION 11-42-.1

OF THE ILLINOIS MUNICIPAL CODE

The undersigned, upon being first duly sworn, hereby certifies to the (Client) Village of Carol Stream that Era-Valdivia Contractors Inc. (Contractor) is not currently delinquent in the payment of any tax administered by or owed to the Illinois Department of Revenue, or otherwise in default upon any such tax as defined under Chapter 24, Section 11-42-.1 Illinois Revised Statutes.

Era-Valdivia Contractors Inc.

Name of Contractor

J. Alvarez

By

President

Title

Subscribed and sworn to before me this 27 day of February, 20 17.

Jesus Alvarez

Notary Public

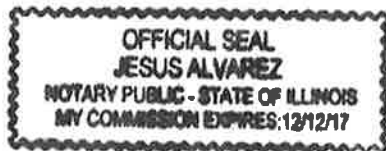

PUBLIC CONTRACTORS -WRITTEN SEXUAL HARASSMENT POLICY
MUST BE COMPLETED AND RETURNED WITH BID FORM

Era-Valdivia Contractors ("Contractor"), having submitted a bid
(Name of Contractor)

for 5-Tanks Misc. Repair to the Village of Carol Stream on

2/27/17 2017, hereby certifies that said Contractor has a written Sexual
(Date)

Harassment Policy in full compliance with 775 ILCS 5/2-105(A) (4).

By: J. G. Valdivia Jose G. Valdivia
Authorized Agent of Contractor (Signature) (Printed) President

Subscribed and sworn to before me this 27th day of February, 2017.

[Signature]
Notary Public



Village of Carol Stream
Interdepartmental Memo

TO: Joe Breinig, Village Manager

FROM: Philip J. Modaff, Director of Public Works 
Ron Roehn, Superintendent of Operations

DATE: March 3, 2017

RE: Recommendation to Award a Contract for Mowing of Rights-of-Way and Village Properties – Beary Landscape Management.

The proposed FY18 budget contains funding for contractor mowing of certain rights-of-way and Village properties. In prior years, one contract was awarded for mowing services and plant bed maintenance. To improve overall services staff has solicited bids for two separate contracts – one for mowing¹ and one for plant bed maintenance². The bid documents also solicited pricing for three one-year extensions at the Village's sole discretion.

A mandatory pre-bid meeting was held for interested contractors on February 21, 2017. Five contractors submitted bids that were opened on February 28, 2017. Bids results are as follows:

<u>COMPANY</u>	<u>BID AMOUNT</u>
Beary Landscape Mgmt.	\$72,097.00
Langton Group	\$75,437.60
Jameson Landscaping	\$79,770.00
Clauss Brothers	\$91,500.00
Alvarez, Inc.	\$55,432.08

While Alvarez, Inc., submitted the lowest bid, following the bid opening Alvarez expressed concern that they had not accurately taken into consideration the performance expectations in the bid specifications. Subsequently, Alvarez requested that their bid be withdrawn (see e-mail attached). The Village Manager and Public Works Director agreed that it is in the best interest of the Village to allow the bidder to withdraw their bid.

Therefore, Beary Landscaping is the apparent low bidder for first year services (and for each of the next three years should the Village choose to exercise one or more of the extensions). Beary

¹ Staff has proposed a budget total of \$120,000 for the two contracts combined and estimating that mowing services would cost approximately \$80,000.

² The bid opening for plant bed maintenance is scheduled for March 14, 2017.

Page Two
March 2, 3017

has satisfactorily performed mowing services for Carol Stream in the past (they are currently under contract through April 30, 2017). Bid documents submitted by Beary Landscaping are in compliance with bid requirements.

Staff recommends that the Mayor and Board approve a Motion awarding a contract to Beary Landscape Management for Mowing of Rights-of-Way and Village Properties, in the amount of \$72,097.00 for the period May 1, 2017, through April 30, 2018.

Attachments

From: Christina Alvarez [mailto:christina@alvarezcorp.com]
Sent: Wednesday, March 01, 2017 10:06 AM
To: Phil Modaff <pmodaff@carolstream.org>
Subject: RE: Alvarez, Inc. Bid Withdraw

Hi Phil,

That is correct. We are confirming receipt of this email confirming that we are withdrawing our bid.

Thank you,



Christina Alvarez
Operations Manager
Alvarez, Inc.
Office: 15N97 Old Sutton Rd.
Barrington, IL 60010
Office: 847-551-1105
Fax: 847-551-1109
Yard: 6311 S. Winchester Ave.
Chicago, IL 60636
Website: www.Alvarezcorp.com

From: Phil Modaff [mailto:pmodaff@carolstream.org]
Sent: Wednesday, March 01, 2017 9:13 AM
To: christina@alvarezcorp.com
Cc: Ron Roehn
Subject: RE: Alvarez, Inc. Bid Withdraw

Christina,

We are in receipt of the attached letter you sent to Ron Roehn this morning. We take this to mean that you are withdrawing your bid for the Village of Carol Stream Mowing Program which was opened on February 28, 2017. If this is indeed your intention please be aware that we will accept your notice of withdrawal and will proceed with making a recommendation to the Carol Stream Village Board to award the contract to another contractor.

Please reply to this e-mail confirming receipt and acknowledging our understanding that the attached letter indicates your withdrawal of your bid.

Phil Modaff
Director of Public Works
Village of Carol Stream

ALVAREZ INC
LANDSCAPE COMPANY

March 1, 2017

Alvarez, Inc. would like to withdraw from contract "Mowing" incorporated by the Village of Carol Stream.

Thank you very much for your time.

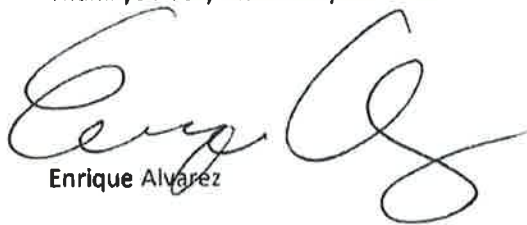

Enrique Alvarez

VILLAGE OF CAROL STREAM BID PROPOSAL FORM

Bidder, in submitting this bid, hereby agrees to comply with all provisions and requirements of the specifications and contract documents attached hereto for the prices as specified below. This bid proposal shall remain in force and full effect for a period commencing on the date of submission and ending thirty (30) days after the date of bid opening.

Bidder, in submitting this bid, hereby agrees to comply with all provisions and requirements of the specifications and contract documents attached hereto for the prices as specified below. This bid shall remain in force and full effect for a twelve (12) month period, from May 1, 2017 through April 30, 2018.

- 1. High-profile Public Facilities: Excluding Village Hall \$ 8,982-
- 2. High-profile Public Facilities: Including Village Hall \$ 9,800-
- 3. Public Properties, Medians and Parkways \$ 63,115-
- GRAND TOTAL: \$ 72,097- 17-18 price
- OPTIONAL WORK (Lawn Mowing) \$.04
per sq. ft.

Rates for services listed for 2017/2018-contract period will not increase more than 0 % for the 2018/2019-contract period. At its sole discretion, the Village of Carol Stream may extend the contract for a one-year term beginning on May 1, 2018 and concluding April 30, 2019.

Rates for services listed for 2018/2019-contract period will not increase more than 2 % for the 2019/2020-contract period. At its sole discretion, the Village of Carol Stream may extend the contract for a one-year term from May 1, 2019 and concluding April 30, 2020.

Rates for services listed for 2019/2020-contract period will not increase more than 2 % for the 2020/2021-contract period. At its sole discretion, the Village of Carol Stream may extend the contract for a one-year term from May 1, 2020 and concluding April 30, 2021.

Company: Beany Landscape Management
 Address: 15001 W 159th Street
Lockport, IL 60491
 Telephone No. 815-838-4100 Fax No. 815-838-3200
 Signature: [Signature]
 Name and Title: (Please Print) Tom Rupp - Manager date: 2-21-17

Subscribed and sworn before me this 21 day of February, 2017

MY COMMISSION EXPIRES: April 22, 2019

NOTARY PUBLIC Kelly Holub

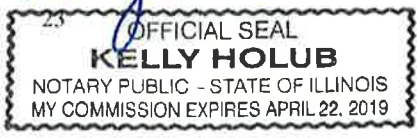

REFERENCES
MUST BE COMPLETED AND RETURNED WITH BID FORM

The Contractor must list at least four (4) references, including at least one (1) municipality or local government, listing the firm name, address, telephone number and contact person, for whom the Contractor has supplied services similar to those provided in these specifications, within the last twenty-four (24) months.

Municipality Name See attached

Municipality Address _____

Contact Name and Phone _____

Work Performed _____

Work Period _____

Company Name _____

Company Address _____

Contact Name and Phone _____

Work Performed _____

Work Period _____

Company Name _____

Company Address _____

Contact Name and Phone _____

Work Performed _____

Work Period _____

Company Name _____

Company Address _____

Contact Name and Phone _____

Work Performed _____

Work Period _____



Governmental References- 2017

Mowing Services/ Joliet Park District

Larry Burich- (815) 741-7275

3000 West Jefferson Street, Joliet, IL 60435

Landscape Maintenance for Sixty Two Joliet Parks (170 Acres Mowed Weekly)

Serviced from 2012 through present, Annual Billings, about \$120,000.00

Mowing, Maintenance & Landscape Services/ City of Lockport

Jenise Lopez (815) 838-0549

921 S. State Street, Lockport, IL 60441

Landscape Maintenance for Seven Locations, various landscape jobs throughout the city

Serviced from 2008 through present, Annual Billings, about \$40,000.00

Mowing, Maintenance Services/ Glen Ellyn Park District

Dan Hopkins (630) 942-7265

185 Spring Avenue, Glen Ellyn, IL 60137

Landscape Maintenance for nineteen parks and additional landscape services provided

Serviced from 2015 through the present, Annual Billings, \$32,500.00

Mowing, Maintenance Services, Carol Stream Park District

Ron Murray (630) 784-6184

849 West Lies Road, Carol Stream, IL 60188

Landscape Maintenance for thirty parks & park facilities

Serviced from 2015 through the present, Annual Billings, \$65,000.00

CONTRACTOR QUESTIONNAIRE
MUST BE COMPLETED AND RETURNED WITH BID FORM

FIRM NAME: Beany Landscape Management

Corporation Partnership Sole Proprietor LLC

OWNER'S NAME: Brian Beany PHONE # 815-838-4100

OWNER'S NAME: — PHONE# —

BUSINESS ADDRESS: 15001 W. 150th Street
Lockport, IL 60491

YEARS IN BUSINESS (under this company name) 32

BANK NAME: First Midwest Bank

BANK ADDRESS: 800 S. State, Lockport, IL

BONDING COMPANY NAME: Assurance Agency

COMPANY ADDRESS: 1750 East Golf Road, Schaumburg

BONDING POWER: 4 million

**CERTIFICATE OF ELIGIBILITY TO CONTRACT
MUST BE COMPLETED AND RETURNED WITH BID FORM**

BearyLandscape Management (Contractor), pursuant to Section 33E-11 of the Illinois Criminal Code of 1961 as amended, hereby certifies that neither (he, she, it) nor any of (his, her, its) partners, officers, or owners of (his, her, its) business has been convicted in the past five (5) years of the offense of bid-rigging under section 33E-3 of the Illinois Criminal Code of 1961 as amended; that neither (he, she, it) nor any of (his, her, its) partners, officers or owners has ever been convicted of the offense of bid-rotating under section 33E-4 of the Illinois Criminal Code of 1961 as amended; and that neither (he, she, it) nor any of (his, her, its) partners, officers or owners has ever been convicted of bribing or attempting to bribe an officer or an employee of the State of Illinois, or has made an admission of guilt of such conduct which is a matter of record.

Date: 2-21-2017

Contractor

SUBSCRIBED and SWORN TO before me
this 21 day of February, 2017

NOTARY PUBLIC





PUBLIC CONTRACTORS -WRITTEN SEXUAL HARASSMENT POLICY
MUST BE COMPLETED AND RETURNED WITH BID FORM

Bear Landscaping Management ("Contractor"), having submitted a bid
(Name of Contractor)

for Lawn Mowing to the Village of Carol Stream on
2-28- 2017, hereby certifies that said Contractor has a written Sexual
(Date)

Harassment Policy in full compliance with 775 ILCS 5/2-105(A) (4).

By: Tom Rupp Tom Rupp
Authorized Agent of Contractor (Signature) (Printed Name)

Subscribed and sworn to before me
this 21 day of February, 2017

Kelly Holub
Notary Public



**FORM OF CONTRACT
VILLAGE OF CAROL STREAM**

THIS AGREEMENT is made this _____ day of _____, 2017, by and between the Village of Carol Stream, an Illinois municipal Corporation hereinafter referred to as (the "Village") and Beary Landcape Management hereinafter to as (the "Contractor") and its successors.

IN CONSIDERATION of the mutual promises of the parties delineated in the contract documents, the Contractor agrees to perform the services and the Village agrees to pay for the services as set forth in the Contract Documents.

1. This contract shall embrace and include all of the Contract Documents listed below as if attached hereto or repeated herein:
 - a. Cover Sheet
 - b. Table of Contents
 - c. Invitation to Bid and Notice to Bidders
 - d. Bid Submittal Checklist
 - e. Instructions to Bidders
 - f. General Conditions of Contract
 - g. Specifications
 - h. Bid Proposal (accepted by the Village)
 - i. References
 - j. Contractor's Questionnaire
 - k. Certification of Eligibility to Contract
 - l. Sexual Harassment Policy Certification
 - m. This Contract
 - n. Required Performance and Payment Bond
 - o. Certificate(s) of Insurance

2. The Village agrees to pay, and the Contractor agrees to accept as full payment for the items which are the subject matter of this contract, the total sum of \$72,097.00 paid in accordance with the provisions of the Local Government Prompt Payment Act.

3. The Contractor represents and warrants that it will comply will all applicable Federal, State and local laws concerning prevailing wage rates and all Federal, State and local laws concerning equal employment opportunities.

4. The Contractor shall perform the work as per the Contract Documents during the period May 1, 2017, through April 30, 2018.
5. In executing this Contract, Contractor agrees that it has examined the site of the work and the conditions existing therein, has examined the Contract Documents and taken and compared field measurements and conditions with those Documents.
6. This Contract and the Contract Documents represent the entire Agreement between the parties and may not be modified without the written approval of both parties.

IN WITNESS WHEREOF, the Village and the Contractor have hereunto set their hands this _____ day of _____, 2017.

 Print Company Name

 By Position/Title

 By Position/Title

THE VILLAGE OF CAROL STREAM, ILLINOIS

 By Mayor

Attest: _____ Village Clerk

Village of Carol Stream
Interdepartmental Memo

TO: Joe Breinig, Village Manager

FROM: Philip J. Modaff, Director of Public Works 
Michele Lopez, Office Manager

DATE: March 2, 2017

RE: Office Furniture Purchase – Public Works Administrative Offices

The FY17 budget contains funding (\$26,000) for replacement of office furniture in six offices in the Public Works Administration building. Staff sought pricing from vendors that could offer pricing under a joint bid contract. Interiors for Business, Inc., offers pricing under the National Joint Powers Alliance (NJPA)¹.

Attached you will find a proposal for the purchase and installation of furniture for the six offices in the amount of \$20,543.85 (see attached). Desk chairs and guest chairs will be purchased separately so that individuals can choose seating that will meet their specific needs. The total price of the office furniture and seating will not exceed the budgeted amount of \$26,000.

Staff recommends that the Village Board approve a Motion authorizing the purchase and installation of office furniture from Interiors for Business, Inc., under NJPA Contract Number 031715-STI in the amount of 20,543.85, pursuant to the provisions of Section 5-8-14(L) of the Carol Stream Code of Ordinances.

Attachments

¹ Carol Stream is a member of NJPA, which leverages the national purchasing power of more than 50,000 member agencies. As a municipal national contracting agency, NJPA establishes and provides competitively solicited purchasing contracts under the guidance of the Uniform Municipal Contracting Law.

Home > Cooperative Purchasing > Contracts - General > Furniture and Storage > Steelcase Inc.



Steelcase Inc.



[Overview](#)

[Contract Documentation](#)

[Pricing](#)

[Marketing Materials](#)

[NJPA Contact Information](#)

HOW TO PURCHASE ?
[Our step-by-step guide](#)

Vendor Contact Info

Kevin Loubert
Direct Phone: 616-246-9455
kloubert@steelcase.com
www.steelcase.com

Contract#: 031715-STI
Category: Furniture and Storage
Sub Category: Furniture
Maturity Date: 04/09/2019

Steelcase is proud to partner with National Joint Powers Alliance (NJPA) as a result of a national bid and contract which NJPA awarded to Steelcase (#031715-STI). This highly competitive contract is available to state and local government, cities, counties, municipalities, schools and all nonprofits. Steelcase provides a wide range of solutions including workstation systems, wood and metal desks, seating for every application, architectural walls, tables, storage, lighting, technology products and work tools - all designed to help you create great environments for office, education, and healthcare.

[Locate your Local Dealer](#)



Interiors for Business, Inc.
 409 N. River Street
 Batavia, Illinois 60510
 630.761.1070 Main
 630.761.1065 Fax
www.interiorsforbusiness.com

CUSTOMER
 Village of Carol Stream
 124 Gerzevske
 Carol Stream, IL 60188

DATE 3/2/2017
TERMS Net 15
PROJECT Office Furnishings

WORKPLACE CONSULTANT
 Paul Jezior

#	QTY	DESCRIPTION	AMOUNT	EXTENDED
STEELCASE - Per Specifications and Prints - NJPA Contract Pricing NJPA Contract # 031715-STI				
	1	ANDREW'S OFFICE	2,269.18	2,269.18
	1	LINDA'S OFFICE	2,751.86	2,751.86
	1	MICHELLE'S OFFICE	2,697.58	2,697.58
	1	MISCELLANEOUS OFFICE	2,006.66	2,006.66
	1	PHIL'S OFFICE	2,296.92	2,296.92
	1	RON'S OFFICE	3,222.90	3,222.90
LABOR				
	1	Receive / Deliver / Install during Normal Business Hours Monday through Friday - Area to be Free and Clear of all Trades prior to Delivery - All Electrical and Data Connections/Disconnections are to be Done by Others - Includes Debris Removal to Installer's Dumpster	5,298.75	5,298.75

	Material	15,245.10
	Sales Tax 8.00%	-
	Freight	-
	Labor	5,298.75
	Design	-
	Total \$	20,543.85

To accept this order please sign and return.

X
 Print Name: _____
 PO Number: _____

Downpayment required at time of order - Ask about available leasing options - This quote is valid for 30 days

Interiors for Business, Inc.

409 N. River St
Batavia, IL 60510

Phone: 1.630.761.1070
Fax: 1.630.761.1065

Quotation

Page 1 of 13

Quote Number	Quote Date	Customer Order Number	Customer Number	Account Representative	Project ID
13273	03/02/17	OFFICES-REVISED	882	House Account	

QUOTE TO:

Village of Carol Stream
124 Gerzevske
Carol Stream, IL 60188

SHIP TO:

Village of Carol Stream
124 Gerzevske
Carol Stream, IL 60188

Terms: Net 15 Days

Line	Quantity	Catalog Number / Description	Unit Price	Extended Amount
BEG	Subsection	ANDREW'S OFFICE		
1	2	TSAEGROM Grommet, Package quantity 10 Tag For: GROM	21.32	42.64
2	1	TS5TLBK3666 Bookcase, 36W x 66H BASIC :25L5 VIRGINIA WALNUT (LPL) TOP-SURF:25L5 VIRGINIA WALNUT (LPL) Tag For: BC/5H/36 ANDREW'S OFFICE	294.86	294.86
3	1	TS5HLDL3072 Desk-Single pedestal, High pressure laminate, Left hand, 30D x 72W BASIC :25L5 VIRGINIA WALNUT (LPL) EDGE :6242 VIRGINIA WALNUT FRONT :25L5 VIRGINIA WALNUT (LPL) LOCK :9201 POLISHED CHROME TOP-SURF:2535 VIRGINIA WALNUT (HPL) OPTIONS * * OPTIONS * * PED OPT *OPT:SINGLE PEDESTAL OPTIONS BBF PED BOX-BOX-FILE PEDESTAL PULLS *OPT:PULL OPTIONS LEDGE LEDGE PULL PULL PULL	638.02	638.02

ACCEPTED BY _____

DATE _____

Interiors for Business, Inc.

409 N. River St
Batavia, IL 60510

Phone: 1.630.761.1070
Fax: 1.630.761.1065

Quotation

Page 2 of 13
(cont'd)

Quote Number	Quote Date	Customer Order Number	Customer Number	Account Representative	Project ID
13273	03/02/17	OFFICES-REVISED	882	House Account	

Line	Quantity	Catalog Number / Description	Unit Price	Extended Amount
4	1	METALLIC *PULL:METALLIC PAINT 4799 PLATINUM METALLIC MOD PNL *OPT:MODESTY PANEL OPTIONS QTR MOD QUARTER HEIGHT MODESTY PANEL Tag For: 30/72 ANDREW'S OFFICE TS5TLWD72 Overhead storage-Wall mount, Doors, 72W BASIC :25L5 VIRGINIA WALNUT (LPL) FRONT :25L5 VIRGINIA WALNUT (LPL) TOP-SURF:25L5 VIRGINIA WALNUT (LPL) OPTIONS * * OPTIONS * * LOCK OPT *OPT:LOCK OPTION WITHLOCK S/C REMOVABLE LOCK LOCK LOCK POL CHR *LOCK:POLISHED CHROME 9201 POLISHED CHROME Tag For: 16/72 ANDREW'S OFFICE	481.62	481.62
5	1	TS5HLRR2448 Return, High pressure laminate, Right hand, 24D x 48W BASIC :25L5 VIRGINIA WALNUT (LPL) EDGE :6242 VIRGINIA WALNUT FRONT :25L5 VIRGINIA WALNUT (LPL) LOCK :9201 POLISHED CHROME TOP-SURF:2535 VIRGINIA WALNUT (HPL) OPTIONS * * OPTIONS * * PED OPT *OPT:SINGLE PEDESTAL OPTONS FF PED STD:FILE-FILE PEDESTAL PULLS *OPT:PULL OPTIONS LEDGE LEDGE PULL PULL PULL METALLIC *PULL:METALLIC PAINT 4799 PLATINUM METALLIC MOD PNL *OPT:MODESTY PANEL OPTIONS QTR MOD QUARTER HEIGHT MODESTY PANEL Tag For: 24/48 ANDREW'S OFFICE	477.48	477.48
6	1	FPAC2TM Tag For: 24/48 ANDREW'S OFFICE	334.56	334.56

ACCEPTED BY _____

DATE _____

Interiors for Business, Inc.

409 N. River St
Batavia, IL 60510

Phone: 1.630.761.1070
Fax: 1.630.761.1065

Quotation

Page 3 of 13
(cont'd)

Quote Number	Quote Date	Customer Order Number	Customer Number	Account Representative	Project ID
13273	03/02/17	OFFICES-REVISED	882	House Account	

Line	Quantity	Catalog Number / Description	Unit Price	Extended Amount
		Eyesite; Monitor arm-Dual, Standard crank column, Through mount bracket BASIC :4799 PLATINUM METALLIC OPTIONS * * OPTIONS * * PIVOTOPT *OPT:PIVOT OPTION NONPIVOT NON PIVOT Tag For: ECDG ANDREW'S OFFICE		
			Subsection Sub Total	2,269.18
			Exempt Sales Tax	0.00
			Subsection Total	2,269.18
END	Subsection			
BEG	Subsection	LINDA'S OFFICE		
7	1	TS5HLSL2472 Credenza-Left hand storage, High pressure laminate, Right hand lateral file, 24D x 72W BASIC :25L5 VIRGINIA WALNUT (LPL) EDGE :6242 VIRGINIA WALNUT FRONT :25L5 VIRGINIA WALNUT (LPL) LOCK :9201 POLISHED CHROME TOP-SURF:2535 VIRGINIA WALNUT (HPL) OPTIONS * * OPTIONS * * PULLS *OPT:PULL OPTIONS LEDGE LEDGE PULL PULL PULL METALLIC *PULL:METALLIC PAINT 4799 PLATINUM METALLIC Tag For: 24/72 LINDA'S OFFICE	869.40	869.40
8	1	TS5HLDL3672 Desk-Single pedestal, High pressure laminate, Left hand, 36D x 72W BASIC :25L5 VIRGINIA WALNUT (LPL) EDGE :6242 VIRGINIA WALNUT FRONT :25L5 VIRGINIA WALNUT (LPL) LOCK :9201 POLISHED CHROME TOP-SURF:2535 VIRGINIA WALNUT (HPL) OPTIONS * * OPTIONS * * PED OPT *OPT:SINGLE PEDESTAL	666.54	666.54

ACCEPTED BY _____

DATE _____

Interiors for Business, Inc.

409 N. River St
Batavia, IL 60510

Phone: 1.630.761.1070
Fax: 1.630.761.1065

Quotation

Page 4 of 13
(cont'd)

Quote Number	Quote Date	Customer Order Number	Customer Number	Account Representative	Project ID
13273	03/02/17	OFFICES-REVISED	882	House Account	

Line	Quantity	Catalog Number / Description	Unit Price	Extended Amount
		OPTIONS BBF PED BOX-BOX-FILE PEDESTAL PULLS *OPT:PULL OPTIONS LEDGE LEDGE PULL PULL PULL METALLIC *PULL:METALLIC PAINT 4799 PLATINUM METALLIC MOD PNL *OPT:MODESTY PANEL OPTIONS FULL MOD STD:FULL HEIGHT MODESTY PANEL Tag For: 36/72 LINDA'S OFFICE		
9	1	TS5TLOH72 Overhead storage-Open, 72W BASIC :25L5 VIRGINIA WALNUT (LPL) TOP-SURF:25L5 VIRGINIA WALNUT (LPL) Tag For: OC/72 LINDA'S OFFICE	403.88	403.88
10	1	TS5HLRR2448 Return, High pressure laminate, Right hand, 24D x 48W BASIC :25L5 VIRGINIA WALNUT (LPL) EDGE :6242 VIRGINIA WALNUT FRONT :25L5 VIRGINIA WALNUT (LPL) LOCK :9201 POLISHED CHROME TOP-SURF:2535 VIRGINIA WALNUT (HPL) OPTIONS * * OPTIONS * * PED OPT *OPT:SINGLE PEDESTAL OPTIONS FF PED STD:FILE-FILE PEDESTAL PULLS *OPT:PULL OPTIONS LEDGE LEDGE PULL PULL PULL METALLIC *PULL:METALLIC PAINT 4799 PLATINUM METALLIC MOD PNL *OPT:MODESTY PANEL OPTIONS QTR MOD QUARTER HEIGHT MODESTY PANEL Tag For: 24/48 LINDA'S OFFICE	477.48	477.48
11	1	FPAC2TM Eyesite; Monitor arm-Dual, Standard crank column,	334.56	334.56

ACCEPTED BY _____

DATE _____

Interiors for Business, Inc.

409 N. River St
Batavia, IL 60510

Phone: 1.630.761.1070
Fax: 1.630.761.1065

Quotation

Page 5 of 13
(cont'd)

Quote Number	Quote Date	Customer Order Number	Customer Number	Account Representative	Project ID
13273	03/02/17	OFFICES-REVISED	882	House Account	

Line	Quantity	Catalog Number / Description	Unit Price	Extended Amount
		Through mount bracket BASIC :4799 PLATINUM METALLIC OPTIONS * * OPTIONS * * PIVOTOPT *OPT:PIVOT OPTION NONPIVOT NON PIVOT Tag For: ECDG LINDA'S OFFICE		
			Subsection Sub Total	2,751.86
			Exempt Sales Tax	0.00
			Subsection Total	2,751.86
END	Subsection			
BEG	Subsection	MICHELLE'S OFFICE		
12	1	TS5TLBK3666 Bookcase, 36W x 66H BASIC :25L5 VIRGINIA WALNUT (LPL) TOP-SURF:25L5 VIRGINIA WALNUT (LPL) Tag For: BC/5H/36 MICHELLE'S OFFICE	294.86	294.86
13	1	TS5HLB2436 Bridge, High pressure laminate, 24D x 36W BASIC :25L5 VIRGINIA WALNUT (LPL) EDGE :6242 VIRGINIA WALNUT TOP-SURF:2535 VIRGINIA WALNUT (HPL) OPTIONS * * OPTIONS * * MOD PNL *OPT:MODESTY PANEL OPTIONS QTR MOD QUARTER HEIGHT MODESTY PANEL Tag For: 24/36 MICHELLE'S OFFICE	176.18	176.18
14	1	TS5HLLL2472 Credenza-Single lateral file, Left hand, 24D x 72W BASIC :25L5 VIRGINIA WALNUT (LPL) EDGE :6242 VIRGINIA WALNUT FRONT :25L5 VIRGINIA WALNUT (LPL) LOCK :9201 POLISHED CHROME TOP-SURF:2535 VIRGINIA WALNUT (HPL) OPTIONS * * OPTIONS * * PULLS *OPT:PULL OPTIONS LEDGE LEDGE PULL	772.34	772.34

ACCEPTED BY _____

DATE _____

Interiors for Business, Inc.

409 N. River St
Batavia, IL 60510

Phone: 1.630.761.1070
Fax: 1.630.761.1065

Quotation

Page 6 of 13
(cont'd)

Quote Number	Quote Date	Customer Order Number	Customer Number	Account Representative	Project ID
13273	03/02/17	OFFICES-REVISED	882	House Account	

Line	Quantity	Catalog Number / Description	Unit Price	Extended Amount
15	1	<p>PULL PULL</p> <p>METALLIC *PULL:METALLIC PAINT</p> <p>4799 PLATINUM METALLIC</p> <p>MOD PNL *OPT:MODESTY PANEL OPTIONS</p> <p>FULL MOD STD:FULL HEIGHT MODESTY PANEL</p> <p>Tag For: 24/72 MICHELLE'S OFFICE</p> <p>TS5HLDR3072</p> <p>Desk-Single pedestal, High pressure laminate, Right hand, 30D x 72W</p> <p>BASIC :25L5 VIRGINIA WALNUT (LPL)</p> <p>EDGE :6242 VIRGINIA WALNUT</p> <p>FRONT :25L5 VIRGINIA WALNUT (LPL)</p> <p>LOCK :9201 POLISHED CHROME</p> <p>TOP-SURF:2535 VIRGINIA WALNUT (HPL)</p> <p>OPTIONS * * OPTIONS * *</p> <p>PED OPT *OPT:SINGLE PEDESTAL OPTIONS</p> <p>BBF PED BOX-BOX-FILE PEDESTAL</p> <p>PULLS *OPT:PULL OPTIONS</p> <p>LEDGE LEDGE PULL</p> <p>PULL PULL</p> <p>METALLIC *PULL:METALLIC PAINT</p> <p>4799 PLATINUM METALLIC</p> <p>MOD PNL *OPT:MODESTY PANEL OPTIONS</p> <p>FULL MOD STD:FULL HEIGHT MODESTY PANEL</p> <p>Tag For: 30/72 MICHELLE'S OFFICE</p>	638.02	638.02
16	1	<p>TS5TLWD72</p> <p>Overhead storage-Wall mount, Doors, 72W</p> <p>BASIC :25L5 VIRGINIA WALNUT (LPL)</p> <p>FRONT :25L5 VIRGINIA WALNUT (LPL)</p> <p>TOP-SURF:25L5 VIRGINIA WALNUT (LPL)</p> <p>OPTIONS * * OPTIONS * *</p> <p>LOCK OPT *OPT:LOCK OPTION</p> <p>WITHLOCK S/C REMOVABLE LOCK</p> <p>LOCK LOCK</p> <p>POL CHR *LOCK:POLISHED CHROME</p> <p>9201 POLISHED CHROME</p> <p>Tag For: 16/72 MICHELLE'S OFFICE</p>	481.62	481.62

ACCEPTED BY _____

DATE _____

Interiors for Business, Inc.

409 N. River St
Batavia, IL 60510

Phone: 1.630.761.1070
Fax: 1.630.761.1065

Quotation

Page 7 of 13
(cont'd)

Quote Number	Quote Date	Customer Order Number	Customer Number	Account Representative	Project ID
13273	03/02/17	OFFICES-REVISED	882	House Account	

Line	Quantity	Catalog Number / Description	Unit Price	Extended Amount
17	1	FPAC2TM Eyesite; Monitor arm-Dual, Standard crank column, Through mount bracket BASIC :4799 PLATINUM METALLIC OPTIONS * * OPTIONS * * PIVOTOPT *OPT:PIVOT OPTION NONPIVOT NON PIVOT Tag For: ECDG MICHELLE'S OFFICE	334.56	334.56
Subsection Sub Total				2,697.58
Exempt Sales Tax				0.00
Subsection Total				2,697.58
END	Subsection			
BEG	Subsection	MISC. OFFICE		
18	1	TS5HLDR3672 Desk-Single pedestal, High pressure laminate, Right hand, 36D x 72W BASIC :25L5 VIRGINIA WALNUT (LPL) EDGE :6242 VIRGINIA WALNUT FRONT :25L5 VIRGINIA WALNUT (LPL) LOCK :9201 POLISHED CHROME TOP-SURF:2535 VIRGINIA WALNUT (HPL) OPTIONS * * OPTIONS * * PED OPT *OPT:SINGLE PEDESTAL OPTIONS BBF PED BOX-BOX-FILE PEDESTAL PULLS *OPT:PULL OPTIONS LEDGE LEDGE PULL PULL PULL METALLIC *PULL:METALLIC PAINT 4799 PLATINUM METALLIC MOD PNL *OPT:MODESTY PANEL OPTIONS FULL MOD STD:FULL HEIGHT MODESTY PANEL Tag For: 36/72 MISC. OFFICE	666.54	666.54
19	1	TS5TLWD36 Overhead storage-Wall mount, Doors, 36W BASIC :25L5 VIRGINIA WALNUT (LPL)	264.50	264.50

ACCEPTED BY _____

DATE _____

Interiors for Business, Inc.

409 N. River St
Batavia, IL 60510

Phone: 1.630.761.1070
Fax: 1.630.761.1065

Quotation

Page 8 of 13
(cont'd)

Quote Number	Quote Date	Customer Order Number	Customer Number	Account Representative	Project ID
13273	03/02/17	OFFICES-REVISED	882	House Account	

Line	Quantity	Catalog Number / Description	Unit Price	Extended Amount
20	1	FRONT :25L5 VIRGINIA WALNUT (LPL) TOP-SURF:25L5 VIRGINIA WALNUT (LPL) OPTIONS * * OPTIONS * * LOCK OPT *OPT:LOCK OPTION WITHLOCK S/C REMOVABLE LOCK LOCK LOCK POL CHR *LOCK:POLISHED CHROME 9201 POLISHED CHROME Tag For: 16/36 MISC. OFFICE TS5TLWD42 Overhead storage-Wall mount, Doors, 42W	300.38	300.38
21	1	BASIC :25L5 VIRGINIA WALNUT (LPL) FRONT :25L5 VIRGINIA WALNUT (LPL) TOP-SURF:25L5 VIRGINIA WALNUT (LPL) OPTIONS * * OPTIONS * * LOCK OPT *OPT:LOCK OPTION WITHLOCK S/C REMOVABLE LOCK LOCK LOCK POL CHR *LOCK:POLISHED CHROME 9201 POLISHED CHROME Tag For: 16/42 MISC. OFFICE TS5HLRL2442 Return, High pressure laminate, Left hand, 24D x 42W	440.68	440.68
		BASIC :25L5 VIRGINIA WALNUT (LPL) EDGE :6242 VIRGINIA WALNUT FRONT :25L5 VIRGINIA WALNUT (LPL) LOCK :9201 POLISHED CHROME TOP-SURF:2535 VIRGINIA WALNUT (HPL) OPTIONS * * OPTIONS * * PED OPT *OPT:SINGLE PEDESTAL OPTIONS FF PED STD:FILE-FILE PEDESTAL PULLS *OPT:PULL OPTIONS LEDGE LEDGE PULL PULL PULL METALLIC *PULL:METALLIC PAINT 4799 PLATINUM METALLIC MOD PNL *OPT:MODESTY PANEL OPTIONS QTR MOD QUARTER HEIGHT MODESTY PANEL Tag For: 24/42		

ACCEPTED BY _____

DATE _____

Interiors for Business, Inc.

409 N. River St
Batavia, IL 60510

Phone: 1.630.761.1070
Fax: 1.630.761.1065

Quotation

Page 9 of 13
(cont'd)

Quote Number	Quote Date	Customer Order Number	Customer Number	Account Representative	Project ID
13273	03/02/17	OFFICES-REVISED	882	House Account	

Line	Quantity	Catalog Number / Description	Unit Price	Extended Amount
22	1	MISC. OFFICE FPAC2™ Eyesite; Monitor arm-Dual, Standard crank column, Through mount bracket BASIC :4799 PLATINUM METALLIC OPTIONS * * OPTIONS * * PIVOTOPT *OPT:PIVOT OPTION NONPIVOT NON PIVOT Tag For: ECDG MISC. OFFICE	334.56	334.56
Subsection Sub Total				2,006.66
Exempt Sales Tax				0.00
Subsection Total				2,006.66
END	Subsection			
BEG	Subsection	PHIL'S OFFICE		
26	1	TS5HLBR4272 Desk-Bow front, High pressure laminate, Single pedestal, Right hand, 42D x 72W BASIC :25L5 VIRGINIA WALNUT (LPL) EDGE :6242 VIRGINIA WALNUT FRONT :25L5 VIRGINIA WALNUT (LPL) LOCK :9201 POLISHED CHROME TOP-SURF:2535 VIRGINIA WALNUT (HPL) OPTIONS * * OPTIONS * * PED OPT *OPT:SINGLE PEDESTAL OPTIONS BBF PED BOX-BOX-FILE PEDESTAL PULLS *OPT:PULL OPTIONS LEDGE LEDGE PULL PULL PULL METALLIC *PULL:METALLIC PAINT 4799 PLATINUM METALLIC Tag For: 42/72 PHIL'S OFFICE	703.80	703.80
27	2	TS5TLWD42 Overhead storage-Wall mount, Doors, 42W BASIC :25L5 VIRGINIA WALNUT (LPL) FRONT :25L5 VIRGINIA WALNUT (LPL) TOP-SURF:25L5 VIRGINIA WALNUT (LPL) OPTIONS * * OPTIONS * *	300.38	600.76

ACCEPTED BY _____

DATE _____

Interiors for Business, Inc.

409 N. River St
Batavia, IL 60510

Phone: 1.630.761.1070

Fax: 1.630.761.1065

Quotation

Page 10 of 13
(cont'd)

Quote Number	Quote Date	Customer Order Number	Customer Number	Account Representative	Project ID
13273	03/02/17	OFFICES-REVISED	882	House Account	

Line	Quantity	Catalog Number / Description	Unit Price	Extended Amount
28	1	LOCK OPT *OPT:LOCK OPTION WITHLOCK S/C REMOVABLE LOCK LOCK LOCK POL CHR *LOCK:POLISHED CHROME 9201 POLISHED CHROME Tag For: 16/42 PHIL'S OFFICE TS5HLUL2448 Shell-Return, High pressure laminate, Left hand, 24D x 48W BASIC :25L5 VIRGINIA WALNUT (LPL) EDGE :6242 VIRGINIA WALNUT TOP-SURF:2535 VIRGINIA WALNUT (HPL) OPTIONS * * OPTIONS * * MOD PNL *OPT:MODESTY PANEL OPTIONS QTR MOD QUARTER HEIGHT MODESTY PANEL	241.50	241.50
29	1	Tag For: 24/48 PHIL'S OFFICE TS5HL2436S2 Storage cabinet-Freestanding, High pressure laminate, 24D x 28 1/2H x 36W BASIC :25L5 VIRGINIA WALNUT (LPL) EDGE :6242 VIRGINIA WALNUT FRONT :25L5 VIRGINIA WALNUT (LPL) LOCK :9201 POLISHED CHROME TOP-SURF:2535 VIRGINIA WALNUT (HPL) OPTIONS * * OPTIONS * * PULLS *OPT:PULL OPTIONS LEDGE LEDGE PULL PULL PULL METALLIC *PULL:METALLIC PAINT 4799 PLATINUM METALLIC Tag For: SC/36 PHIL'S OFFICE	416.30	416.30
30	1	FPAC2TM Eyesite; Monitor arm-Dual, Standard crank column, Through mount bracket BASIC :4799 PLATINUM METALLIC OPTIONS * * OPTIONS * * PIVOTOPT *OPT:PIVOT OPTION	334.56	334.56

ACCEPTED BY _____

DATE _____

Interiors for Business, Inc.

409 N. River St
Batavia, IL 60510

Phone: 1.630.761.1070
Fax: 1.630.761.1065

Quotation

Page 11 of 13
(cont'd)

Quote Number	Quote Date	Customer Order Number	Customer Number	Account Representative	Project ID
13273	03/02/17	OFFICES-REVISED	882	House Account	

Line	Quantity	Catalog Number / Description	Unit Price	Extended Amount
		NONPIVOT NON PIVOT Tag For: ECDG PHIL'S OFFICE		
			Subsection Sub Total	2,296.92
			Exempt Sales Tax	0.00
			Subsection Total	2,296.92
END	Subsection			
BEG	Subsection	RON'S OFFICE		
31	1	TS5HLB2436 Bridge, High pressure laminate, 24D x 36W BASIC :25L5 VIRGINIA WALNUT (LPL) EDGE :6242 VIRGINIA WALNUT TOP-SURF:2535 VIRGINIA WALNUT (HPL) OPTIONS * * OPTIONS * * MOD PNL *OPT:MODESTY PANEL OPTIONS QTR MOD QUARTER HEIGHT MODESTY PANEL Tag For: 24/36 RON'S OFFICE	176.18	176.18
32	1	TS5HLLL2472 Credenza-Single lateral file, Left hand, 24D x 72W BASIC :25L5 VIRGINIA WALNUT (LPL) EDGE :6242 VIRGINIA WALNUT FRONT :25L5 VIRGINIA WALNUT (LPL) LOCK :9201 POLISHED CHROME TOP-SURF:2535 VIRGINIA WALNUT (HPL) OPTIONS * * OPTIONS * * PULLS *OPT:PULL OPTIONS LEDGE LEDGE PULL PULL PULL METALLIC *PULL:METALLIC PAINT 4799 PLATINUM METALLIC MOD PNL *OPT:MODESTY PANEL OPTIONS FULL MOD STD:FULL HEIGHT MODESTY PANEL Tag For: 24/72 RON'S OFFICE	772.34	772.34
33	1	TS5HL2436F2 File-Lateral, High pressure laminate,	524.86	524.86

ACCEPTED BY _____

DATE _____

Interiors for Business, Inc.

409 N. River St
Batavia, IL 60510

Phone: 1.630.761.1070

Fax: 1.630.761.1065

Quotation

Page 12 of 13
(cont'd)

Quote Number	Quote Date	Customer Order Number	Customer Number	Account Representative	Project ID
13273	03/02/17	OFFICES-REVISED	882	House Account	

Line	Quantity	Catalog Number / Description	Unit Price	Extended Amount
34	2	Freestanding, 24D x 28 1/2H x 36W BASIC :25L5 VIRGINIA WALNUT (LPL) EDGE :6242 VIRGINIA WALNUT FRONT :25L5 VIRGINIA WALNUT (LPL) LOCK :9201 POLISHED CHROME TOP-SURF:2535 VIRGINIA WALNUT (HPL) OPTIONS * * OPTIONS * * PULLS *OPT:PULL OPTIONS LEDGE LEDGE PULL PULL PULL METALLIC *PULL:METALLIC PAINT 4799 PLATINUM METALLIC Tag For: LF/2/36 RON'S OFFICE	337.64	675.28
35	1	TS5TLWD48 Overhead storage-Wall mount, Doors, 48W BASIC :25L5 VIRGINIA WALNUT (LPL) FRONT :25L5 VIRGINIA WALNUT (LPL) TOP-SURF:25L5 VIRGINIA WALNUT (LPL) OPTIONS * * OPTIONS * * LOCK OPT *OPT:LOCK OPTION WITHHLOCK S/C REMOVABLE LOCK LOCK LOCK POL CHR *LOCK:POLISHED CHROME 9201 POLISHED CHROME Tag For: 16/48 RON'S OFFICE	302.68	302.68
36	1	TS5LBBF23U Pedestal-Under worksurface, Box / box / file, 23D x 27H BASIC :25L5 VIRGINIA WALNUT (LPL) FRONT :25L5 VIRGINIA WALNUT (LPL) LOCK :9201 POLISHED CHROME OPTIONS * * OPTIONS * * PULLS *OPT:PULL OPTIONS LEDGE LEDGE PULL PULL PULL METALLIC *PULL:METALLIC PAINT 4799 PLATINUM METALLIC Tag For: BBF RON'S OFFICE	437.00	437.00

ACCEPTED BY _____

DATE _____

Interiors for Business, Inc.

409 N. River St
Batavia, IL 60510

Phone: 1.630.761.1070
Fax: 1.630.761.1065

Quotation

Page 13 of 13
(cont'd)

Quote Number	Quote Date	Customer Order Number	Customer Number	Account Representative	Project ID
13273	03/02/17	OFFICES-REVISED	882	House Account	

Line	Quantity	Catalog Number / Description	Unit Price	Extended Amount
37	1	High pressure laminate, Curved front, Right hand, 24D x 36WL x 66WR BASIC :25L5 VIRGINIA WALNUT (LPL) EDGE :6242 VIRGINIA WALNUT TOP-SURF:2535 VIRGINIA WALNUT (HPL) OPTIONS * * OPTIONS * * MOD PNL *OPT:MODESTY PANEL OPTIONS FULL MOD STD:FULL HEIGHT MODESTY PANEL Tag For: 36/66 RON'S OFFICE FPAC2TM Eyesite; Monitor arm-Dual, Standard crank column, Through mount bracket BASIC :4799 PLATINUM METALLIC OPTIONS * * OPTIONS * * PIVOTOPT *OPT:PIVOT OPTION NONPIVOT NON PIVOT Tag For: ECDG RON'S OFFICE	334.56	334.56
Subsection Sub Total				3,222.90
Exempt Sales Tax				0.00
Subsection Total				3,222.90
END	Subsection			

QUOTATION TOTALS

Sub Total	15,245.10
Exempt Sales Tax	0.00
Grand Total	15,245.10

*****End of Quotation*****

ACCEPTED BY _____

DATE _____

Village of Carol Stream
INTER-DEPARTMENTAL MEMO

TO: Mayor and Trustees
FROM: Robert Mellor, Assistant Village Manager
DATE: March 3, 2017
RE: Award of Contract – Relocation Services

The Village advertised for competitive, sealed bids from licensed moving companies to move designated furniture, equipment, boxes, etc. from the Village Hall/Police Station's existing facility at 500 N. Gary Avenue to alternate temporary locations:

- Village of Glendale Heights Police Facility located at 300 E. Fullerton Avenue, in Glendale Heights (PD Investigations, SOU and Traffic Units)
- Temporary Village Hall/Police Facility located at 505 E. North Avenue, in Carol Stream, IL (Village and Police Administration, Police Records and Social Services Unit)
- Temporary Storage Locker in the industrial park (furniture not being moved to the temporary facility)

During the pre-bid process a number of questions were raised by potential bidders and six (6) addenda were issued in an attempt to clarify the scope of the work. On February 28, 2017 at 10:00 a.m., sealed bids were opened for relocation services for the Village Hall & Police Station/Renovation project. The bid results were as follows:

Bidder	Base Bid	Moving Days
Glen Ellyn Storage Corp. – Carol Stream	\$31,550	4
McCollister's Transportation Group, Inc. – West Chicago	\$51,129	10

References for both moving companies were verified and reflected positively on their services.

After the bids were examined it was determined that both bidders either included or excluded certain work for the project. One bidder's bid included work not necessary and excluded by an addendum. The other bidder's bid excluded work requested per the scope of the work. Therefore, since the bids are not comparable and were not fully responsive, it is the Village staff recommendation that the bids be rejected and the Village waive competitive bidding and award a contract to Glen Ellyn Storage Corporation in the amount of \$32,625.00. This contract amount includes all of the work required by the Village for this Project.

There are sufficient funds budgeted for these relocation service expenses.

Please contact me if you have any questions.

Cc: Joseph E. Breinig, Village Manager

March 2, 2017

Mr. Robert Mellor
Assistant Village Manager
Village of Carol Stream
500 N. Gary Avenue
Carol Stream, IL 60188

Re: Furniture Moving Bids - Summary of Bid Review

Dear Bob,

We have interviewed the two bidders and they have proposed to perform the move utilizing two different methods.

McCollister's Transportation included 3 days of planning with the Village Staff to coordinate the move and to show the staff how to use E-Crates. E-Crates are plastic containers that you stack 4 high on top of a 4 wheeled dolly as you load them. They can be zip tied shut, locked or left unlocked. The advantage of the E-Crates is that they greatly reduce the amount of lifting and carrying of loaded boxes by the village staff. You place an empty E-Crate on top of a 4 wheel dolly, load it, then you stack another E-Crate on top of the first one and so on until you are 4 crates tall. Staff can push the stack as they need to as they fill them and then push the stack to a planned staging area. When the E-Crates arrive at the Temporary Facility they are still on the dollies, can be unloaded from the top on down, never having to lift or carry a full E-Crate. McCollister's figured a 6 week rental on 400 E-Crates and 100 four wheeled dollies. We have asked them for a credit to reduce the rental period to 4 weeks. McCollister's has included 200 tote Cartons for use boxing items that are not planned to be unpacked at the Temporary Facilities.

McCollister's Base Bid,	\$51,129.00
Reduce E-Crate to 4 weeks,	(\$ 1,120.00)
Alternate Chairs to storage Facility,	<u>\$ 460.00</u>
Proposed Contract Amount,	\$50,469.00

Glen Ellyn Storage Corp has proposed to supply 450 tote cartons/ boxes. Post bid we asked them to provide a cost for the use of 400 E-Crates, 100 four wheeled dollies and 200 tote boxes and we will show that cost below. Glen Ellyn Storage also provided with their bid, the optional alternate for electrical work that we requested and did so as a \$1,950.00 deduct to the contract amount. They did not show an alternate price for moving the Village Board Meeting Room chairs, as requested with their bid but have now given us a cost of \$300.00 to move the chairs. Post bid they have acknowledged that they did receive addendum #1 prior to the bid and did include the required Contract and Insurance requirements in their bid.

Glen Ellyn Storage Corp Base Bid	\$31,550.00
Eliminate Electrical Work	(\$ 1,950.00)
Alternate Chairs to Storage Facility	<u>\$ 300.00</u>
Proposed Contract Amount	\$29,900.00

Mr. Robert Mellor
March 2, 2017
Page 2

The cost for Glen Ellyn Storage Corp to utilize 400 E-Crates, 100 four wheeled dollies for 4 weeks and to supply only 200 tote cartons would be as follows.

Glen Ellyn Storage Corp, Proposed Contract Amount	\$29,900.00
E-Crate Proposal	<u>\$ 2,725.00</u>
Proposed E-Crate Method Contract Amount	\$32,625.00

We have attached both Mover's References. We have called all 6 of the references given by each Mover, able to get ahold of 2 of McCollister's who gave sterling reviews and 2 of Glen Ellyn Storage Corp's who also gave sterling reviews.

In conclusion we believe that both Bidders are qualified, that Glen Ellyn Storage and Moving Corp is your qualified low bidder if your Council is agreeable to waving the minor irregularity that addendum #1 was not acknowledged by Glen Ellyn Storage with the bid. Remember that part of Addendum #1 was the announcement changing the time of the Pre-Bid Meeting that Glen Ellyn Storage did attend at the proper time and have confirmed in writing that they did receive addendum #1 before the bid and did include the addendum items in their bid. The Village may wish to award the Base Bid amount and then execute change orders for the changes in scope.

Due to the fact that the Village Staff may not all be accustomed to lifting and carrying heavy boxes we would recommend the use of the E-Crate method of packing.

Sincerely,

MTI Construction Services, LLC



Steve Karecki
Project Manager



CONSTRUCTION SERVICES

CSVH & Police Temporary Facility - 505 E. North Avenue

Furniture Moving Bid Package

Bid Date

2/28/17

Bid Summary

Page: 1 of 1

	Bidder	Base Bid	Bid Bond	Adendums 1-6	Alternate Chairs	Bid & Alternate
1.	Glen Ellyn Storage Corp	\$31,550.00	Cashier Check	2-6 and 1*	\$300.00*	\$31,550.00
2.	McCollisters	\$51,129.00	yes	yes	\$460.00	\$51,589.00
3.						
4.						
5.						
6.						

* Provided post bid.



Glen Ellyn Storage Corp.

February 27, 2017

Village of Carol Stream
500 N Gary Ave
Carol Stream, IL 60188

Below please find the estimated costs for the relocation of the village offices to their new location at 505 E. North Ave and Glendale Heights, Straight time with non union labor.

Moving labor :	
13 men + 3 Trucks X 8-1/4 hours X 3 days	\$18,700.00
5 Men + 1 truck X 6 hours	\$ 2,000.00
450 cartons including delivery	\$1450.00
Disassembly of rolling file storage	\$1650.00
Disassembly of 8 workstations	\$550.00
Reassembly of 8 workstations	\$1750.00
Reconnect electrical of for 8 work stations	\$1950.00
Reassembly of rolling file storage	\$3500.00
Total for all services	\$31550.00

Moving services to include loading, transportation, delivery and positioning by professional movers. The above proposal is based on .30 per pound/ per article liability, straight time (M-F 8:00AM-5:00PM), non union labor.

Please let me know if you have any questions or require any additional information.

Stephen Price
Glen Ellyn Storage Corp
465 Fullerton Ave
Carol Stream, IL 60188
630 370 3069

MOVING SERVICE BID PROPOSAL FORM

Trade Specific: FURNITURE MOVING SERVICES
Bid Due Date: NLT 10 am, Tuesday, February 28, 2017
Name of Bidder: Glen Ellyn Storage Corp.
Business Address: 465 E Fullerton Ave
Carol Stream IL 60188
Bidder Principals: Stephen Price

Telephone Number: 630-970-3069
Facsimile Number: 630-543-0917
Project: TEMPORARY VILLAGE HALL/POLICE FACILITY
Village of Carol Stream
505 E. North Avenue
Carol Stream, Illinois 60188

Construction Manager: MTI Construction Services, LLC
328 Eisenhower Lane North
Lombard, Illinois 60148

Architect: Williams Architects
500 Park Boulevard, Suite 800
Itasca, Illinois 60143

Ladies & Gentlemen:

Pursuant to the Notice to Bid, inviting proposals for the subject project, we have carefully reviewed and examined all Bid and Contract Documents transmitted and the undersigned proposes to furnish everything, including contingencies, labor, materials, tools, equipment, supervision, including any use and excise taxes called for or reasonably implied by the said documents for the above referenced Bidder's work for the Lump Sum Moving Service Bid Proposal of _____

THIRTY ONE THOUSAND FIVE HUNDRED FIFTY ^{00/100} \$ 31,550

Said Lump Sum Moving Bid shall equal the total indicated on the attached Bid Breakdown Form, less exempt sales taxes.

NOTE: If voluntary alternates are to be submitted, attach to Moving Service Bid Proposal on Bidder's letterhead. DO NOT INCLUDE IN BASE BID!!

The undersigned understands that time is of the essence for the completion of the Project and hereby agrees that all work included in the Bid and Construction Documents shall be completed in 4 calendar days.*

The undersigned further states that he will employ the following list of sub-subcontractors and/or suppliers for each of the major work categories, subject to Construction Manager review and approval, as shown.

List the name, address, phone number and sub-subcontractor's license number of all sub-subcontractors and/or suppliers to be used on this project and indicate what part of the work will be done or provided by each sub-subcontractor and/or supplier.

Breakdown for total calendar days is as follows:

Note: The following time frames must support the commencement of the moving services work no later than April 10, 2017 (i.e., Police to Glendale Heights Police), with 100% Completion by no later than April 24, 2017.

Contract execution & insurance:	<u>—</u>	calendar days.
Apply for any permits:	<u>—</u>	calendar days.
Pre-planning & establish communications with Village:	<u>—</u>	calendar days.
Deliver E-crates, carts, bins, boxes, labels, packing & moving supplies, etc.:	<u>—</u>	calendar days.
Move Police Investigations to Glendale Heights Police facility:	<u>1</u>	calendar days.
Move Police Records to 550 E. North Avenue, in (2) different shifts:	<u>1</u>	calendar days
Move Police Dept., Social Services, Community Development Dept., Engineering, and Finance Dept.:	<u>1</u>	calendar days
Move Village Administration and Human Resources Dept.:	<u>1</u>	calendar days
Post move:	<u>—</u>	calendar days
Total:	<u>4</u>	calendar days.

Work to be Performed By These Sub-Subcontractors

<u>Name/License No.</u>	<u>Address/Phone Number</u>
1. <u>Pennington Ingalls Corp.</u>	<u>3400 West 111th St #110</u> <u>Chicago, IL 60655</u> <u>708-925-9770</u>
2. _____	_____
3. _____	_____
4. _____	_____
5. _____	_____
6. _____	_____
7. _____	_____
8. _____	_____
9. _____	_____
10. _____	_____

Continue on additional sheet if required.

The undersigned also acknowledges receipt, understanding and full consideration of the following addenda to the Bid Documents:

Addendum Number 2-6

Date 2/27/17

Addendum Number _____

Date _____

BID BREAKDOWN FORM

Page _____ of _____

Moving Bidder: Glen Ellyn Storage Corp
 Address: 465 E Fullerton Ave, Carol Stream, IL 60188
 Email: sprice@glenellynmoving.com
 Phone: 630-370-3069

(Whole dollars only)

DESCRIPTION OF WORK (Itemize Bid for Each Type of Moving Item)	Quantity	Unit Price	Extension
Labor			18,700
Trucks			2,000
Cartons			1,450
Disassembly of file stg			1,650
↳ of workstations	8		550
Reassembly of workstations	8		1,750
Reconnect electrical of workstations	8		1,950
Reassembly of file storage			3,500
Contingency Allowance			
Trash & Rubbish Removal			
LUMP SUM BID TOTAL			31,550.00

The undersigned hereby designates as his representative as Project Manager Stephen Price and as Field Superintendent for the subject project, however, this designation is subject to the Village of Carol Stream and Construction Manager's review and written approval. Further understand that either the Village of Carol Stream or the Construction Manager reserves the right to request substitution for Moving Bidder's representatives.

By:

Steph P.
Moving Bidder's Seal

Title:

Relocation Consultant

License No:

IL ICC 53545

License Expiration Date:

—

Attachments, required as part of this bid are:

- (a) Moving Bid Proposal Form; (b) Bid Breakdown Form; (c) Any Voluntary Alternates

INDEPENDENT CONTRACTOR'S AGREEMENT

THIS AGREEMENT entered into by and between Glen Ellyn Storage Corp. herein referred to as the "*First Party*"; and the **VILLAGE OF CAROL STREAM**, 500 North Gary Avenue, DuPage County, Illinois, hereinafter referred to as the "*Second Party*".

WHEREAS, "*First Party*" will be performing various work under contracts with the said "*Second Party*" entered into and to be entered into from time to time, which work will be performed on and/or off the premises of the "*Second Party*" and said "*First Party*" may have subcontractors or one or more employees engaged in the performance of said work;

NOW, THEREFORE, in consideration of the mutual covenants and agreements herein contained, and other good and valuable consideration received and to be received, the "*First Party*" hereby agrees:

1. To comply with all laws, regulations and rules promulgated by any Federal, State, County, Village and/or other governmental unit or regulatory body now in effect or which may be in effect during the performance of the work to which reference is made above. Included within the scope of the laws, regulations and rules referred to in this paragraph but in no way to operate as a limitation, are all forms of traffic regulations, public utility and Intrastate and Interstate Commerce Commissions regulations, Workmen's Compensation Laws, Prevailing Wage Laws, the Social Security Act of the Federal Government and any of its titles, FEPC or EEOC statutory provisions and rules and regulations.
2. To protect, indemnify, hold and save harmless and defend the "*Second Party*" against any and all claims, costs causes, actions and expenses, including but not limited to attorney's fees incurred by reason of a lawsuit or claim for compensation arising in favor of any person, including the employees or officers or independent contractors or subcontractors of the first and second parties, on account of personal injuries or death, or damages to property occurring, growing out of, incident to, or resulting directly or indirectly from the performance by the "*First Party*" hereunder, including use of equipment and resources of the "*Second Party*" by the "*First Party*" whether such loss, damage, injury or liability is contributed to by the negligence of the "*Second Party*" whether latent or patent, or from other causes whatsoever, except that the "*First Party*" shall have no liability or damages or the costs incident thereto caused by the sole negligence of the "*Second Party*".
3. To keep in force, to the satisfaction of the "*Second Party*", at all times during the performance of the work referred to above, Commercial General Liability Insurance and Automobile Liability Insurance with Bodily Injury limits of not less than \$1,000,000 and Property Damage Insurance with limits of not less than \$1,000,000. The "*First Party*" agrees that at any time upon the demand of the "*Second Party*" proof of such insurance coverage as will be submitted to the "*Second Party*". There shall be no additional charge for said insurance to the "*Second Party*".
4. To maintain all records and documents for projects of the Public Body of the Village of Carol Stream in compliance with the Freedom of Information Act, 5ILCS 140/4 et seq. In addition, Contractor shall produce, without cost to the municipality, records which are responsive to a request received by the Public Body under the Freedom of Information Act so that the Public Body may provide records to

PUBLIC CONTRACTORS -WRITTEN SEXUAL HARASSMENT POLICY

Glen Ellyn Storage Corp. ("Contractor"), having contracted for
(Name of Contractor)

Remodeling work for the Village of Carol Stream on Feb 28 2017, hereby certifies that
(Date)
said Contractor has a written Sexual Harassment Policy in full compliance with 775 ILCS 5/2-105(A) (4).

By: Steph Price
Authorized Agent of Contractor (Signature)

Stephen Price
(Printed)

Subscribed and sworn to before me this 28th day of February, 2017.

Kristine Sanders

Notary Public



CERTIFICATE OF ELIGIBILITY TO CONTRACT

Glen Ellyn Storage Corp (Contractor), pursuant to section 33E-11 of the Illinois Criminal Code of 1961 as amended, hereby certifies that neither (he, she, it) nor any of (his, her, its) partners, officers, or owners of (his, her, its) business has been convicted in the past five (5) years of the offense of bid-rigging under section 33E-3 of the Illinois Criminal Code of 1961 as amended; that neither (he, she, it) nor any of (his, her, its) partners, officers or owners has ever been convicted of the offense of bid-rotating under section 33E-4 of the Illinois Criminal Code of 1961 as amended; and that neither (he, she, it) nor any of (his, her, its) partners, officers or owners has ever been convicted of bribing or attempting to bribe an officer or an employee of the State of Illinois, or has made an admission of guilt of such conduct which is a matter of record.

Date: Feb 28, 2017

Contractor: Stephen Ricci

SUBSCRIBED and SWORN TO before me
this 28th day of February, 2017.

NOTARY PUBLIC
Kristine Sanders



CERTIFICATION

I, Stephen Price (Individual), having been first duly sworn on oath, do
depose and state that I presently reside at 563 Carlisle Cr. Glen Ellyn, IL
(Address), and that I am the duly authorized principal, officer or agent of Glen Ellyn Storage Corp.

(Name of Moving Service Bidder) and do hereby certify to Village of Carol Stream, its
Village Board, officers and employees that neither I nor Glen Ellyn Storage Corp.
(Name of Moving Service Bidder) are barred from bidding on the contract for which this bid is submitted,
as a result of violation of either Section 33E-3 ("Bid-rigging") or Section 33E-4 ("Bid-rotating") of Article
33E of the Criminal Code of 1961 of the State of Illinois approved July 28, 1961, as amended.

Steph Price

Individually and on behalf of Moving Service Bidder

Subscribed and sworn to before me

This 27th day of February, 2017

Kristine Sanders

Notary Public

My commission expires: 9/16/19



AN ORDINANCE APPROVING A SPECIAL USE PERMIT TO ALLOW FOR OUTDOOR ACTIVITIES AND OPERATIONS IN THE FORM OF A VAPORIZER AND TRIFECTA EQUIPMENT IN THE I INDUSTRIAL DISTRICT (ANTUNES, 180 KEHOE BOULEVARD)

WHEREAS, Sergio Flores of Antunes, hereinafter referred to as the Petitioner, has petitioned the Village of Carol Stream for a Special Use Permit to allow for outdoor activities and operations in the form of a vaporizer and trifecta equipment in the I Industrial District, as provided in Section 16-10-2(B)(14) of the Carol Stream Code of Ordinances, on the property legally described in Section 2 herein and commonly known as 180 Kehoe Boulevard, Carol Stream, Illinois; and

WHEREAS, pursuant to Section 16-15-8 of the Carol Stream Code of Ordinances, the Combined Plan Commission/Zoning Board of Appeals held a public hearing on the above petition on February 27, 2017, following proper legal notice of said public hearing, after which the Commission recommended to the Mayor and Board of Trustees of the Village that the Special Use Permit be approved; and

WHEREAS, the Combined Plan Commission/Zoning Board of Appeals has filed its Findings and Recommendations regarding the Special Use Permit with the Mayor and Board of Trustees, and the Mayor and Board of Trustees have duly considered said Findings and Recommendations.

NOW, THEREFORE, BE IT ORDAINED BY THE MAYOR AND BOARD OF TRUSTEES OF THE VILLAGE OF CAROL STREAM, DU PAGE COUNTY, ILLINOIS, IN THE EXERCISE OF ITS HOME RULE POWERS, AS FOLLOWS:

SECTION 1:

The Mayor and Board of Trustees of the Village of Carol Stream, after examining the Petition for the Special Use Permit to allow for a vaporizer and trifecta equipment, and the Findings and Recommendations of the Combined Plan Commission / Zoning Board of Appeals, have determined and find that the requested Special Use Permit:

1. Is deemed necessary for the public convenience at the location. *Antunes requires the additional equipment to enable efficient processing of important product lines.*
2. Will not be unreasonably detrimental to or endanger the public health, safety, morals, comfort or general welfare. *The additional equipment will not be detrimental to or endanger the public health, safety, morals, comfort or general welfare.*
3. Will not be injurious to the use and enjoyment of other property in the immediate vicinity for the purposes already permitted, nor substantially diminish and impair property values within the neighborhood. *Other industrial properties have received Special Use approval for outdoor activities and operations for silos, tanks, or other types of outdoor pieces of equipment, with no apparent injury to the use or enjoyment of properties in the immediate vicinity, or diminution or impairment to property values within the neighborhood.*

4. Will not impede the normal and orderly development and improvement of surrounding property for uses permitted in the district. *The surrounding properties are already developed. This criterion is not applicable.*
5. Will provide adequate utilities, access roads, drainage and other important and necessary community facilities. *Adequate utilities, access roads, drainage and other public improvements are already in place.*
6. Will conform to the applicable regulations of the district in which it is located, except as the Village Board may in each instance modify such regulations. *The proposal is expected to conform to all applicable codes and requirements.*

SECTION 2:

The Special Use Permit, as set forth in the above recitals, is hereby approved and granted to Antunes subject to the conditions set forth in Section 3, upon the real estate commonly known as 180 Kehoe Boulevard, Carol Stream, Illinois, and legally described as follows:

LOT 3 IN THE NARDI PROPERTY SUBDIVISION, BEING A SUBDIVISION OF PART OF THE EAST ½ OF SECTION 32, TOWNSHIP 40 NORTH, RANGE 10, EAST OF THE THIRD PRINCIPAL MERIDIAN, ACCORDING TO THE PLAT THEREOF, RECORDED AS DOCUMENT R1998-245819, IN DUPAGE COUNTY, IL.

hereinafter referred to as the Subject Property.

SECTION 3:

The approval of the Special Use Permit granted in Section 1 herein is subject to the following conditions:

1. That the northernmost evergreen tree on the west side of the property be replaced with a new evergreen, along with the installation of 2-3 additional evergreens to the north of said tree, to provide additional screening of the new equipment. The evergreen trees shall be a minimum of six feet in height upon installation, and shall be installed no later than May 15, 2017.
2. That the slats in the existing fence shall be maintained, and if any slats are damaged or are in poor condition, they will be replaced immediately in order to provide proper screening of the lower portions of the equipment; and
3. That the site must be maintained and the business must be operated in accordance with all State, County and Village codes and regulations.

SECTION 4:

The Special Use Permit is hereby approved and granted as set forth in the following plans and exhibits:

1. Site Plan with Equipment Detail (Exhibit A, dated December 21, 2016), prepared by Engineering Resources Associates, Inc., 3S701 West Avenue, Suite 150, Warrenville, IL 60555.
2. Thermax Vaporizer Drawing (Exhibit B, dated October 21, 2009), prepared by Thermax Inc., 540 Hawthorn Street, Dartmouth, MA 02747.
3. Trifecta Cut Sheet (Exhibit C, dated 2010).

SECTION 5:

This Ordinance shall be in full force and effect from and after passage, approval and publication in pamphlet form, provided, however, that this Ordinance is executed by the owners or such other party in interest, consenting to and agreeing to be bound by all of the terms and conditions contained within this Ordinance. Such execution and delivery to the Village shall take place within sixty (60) days after the passage and approval of this Ordinance or within such extension of time as may be granted in the discretion of the corporate authorities, by motion.

SECTION 6:

The failure of the owner or other party in interest, or a subsequent owner or other party in interest, to strictly comply with the terms and conditions of this Ordinance, after execution of this Ordinance, shall subject the owner or party in interest to the penalties set forth in Section 16-17-7 A and B of the Carol Stream Code of Ordinances, and/or termination of the special use permits after notice and public hearing in accordance with the procedures required by the Carol Stream Code of Ordinances.

PASSED AND APPROVED THIS 6th DAY OF MARCH, 2017.

AYES:

NAYS:

ABSENT:

Frank Saverino, Sr. Mayor

ATTEST:

Laura Czarnecki, Village Clerk

I, Sergio Flores, being the owner and/or party in interest of the Subject Property legally described in this ordinance, do hereby accept, concur, and agree to develop and use the Subject Property in accordance with the terms and conditions of this Ordinance, and I understand that if I do not do so, I am subject to the penalties set forth in Section 16-17-7 A and B of the Carol Stream Code of Ordinances, and/or termination of the special use permit. Antunes further agrees to indemnify, hold harmless and defend the Village, and its officers, agents and employees from any and all claims, lawsuits, liabilities damages and costs incurred as a result of the approvals as granted herein.

Date

Owner/Party In Interest

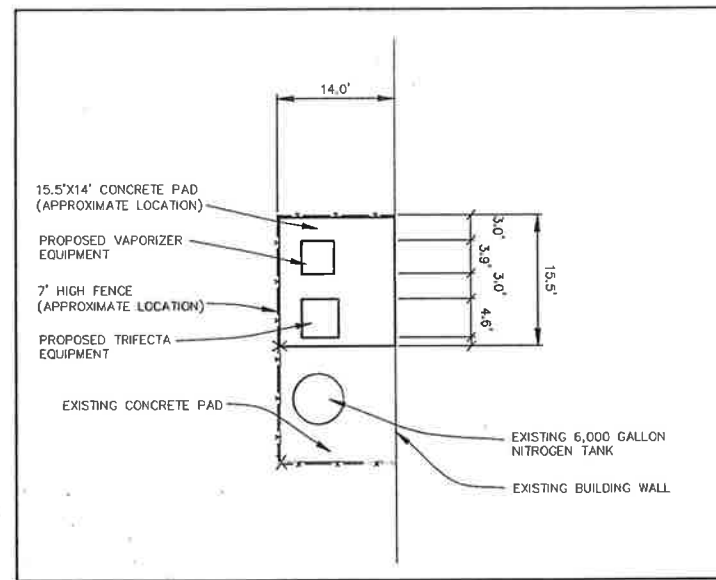

EQUIPMENT DETAIL A
SCALE: 1"=10'

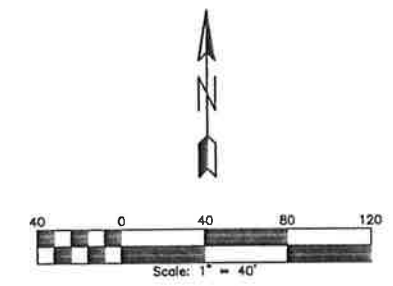
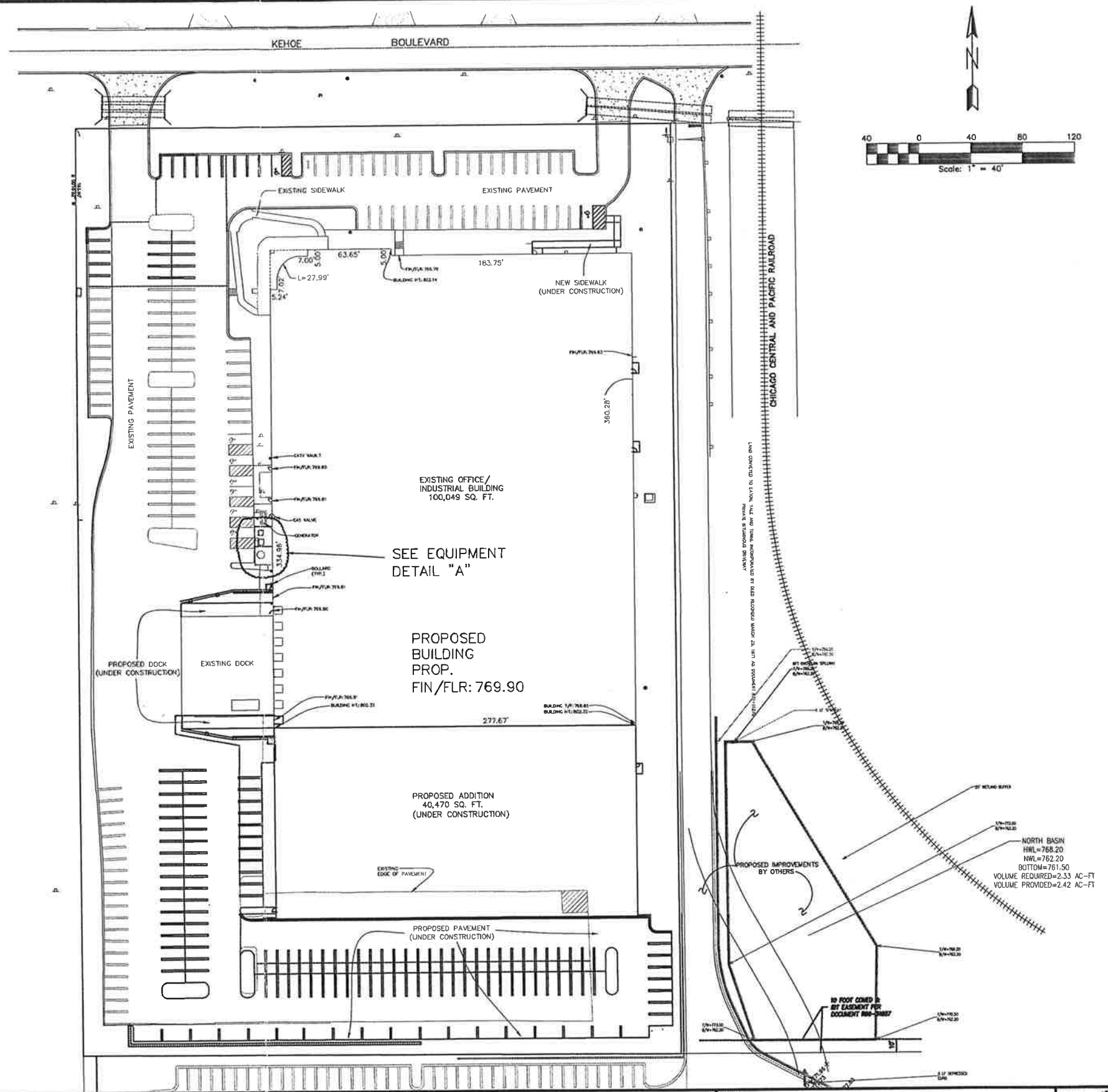

REVISIONS:	DATE	BY	DESCRIPTION	DATE	BY	DESCRIPTION

DRAWN BY: E.M.
CHECKED BY: M.H.
APPROVED BY: J.G.



ENGINEERING RESOURCE ASSOCIATES, INC.
CONSULTING ENGINEERS, SCIENTISTS & SURVEYORS

35701 WEST AVENUE, SUITE 150
WARRENVILLE, ILLINOIS 60555
PHONE (630) 393-3060
FAX (630) 393-2152

10 S. RIVERSIDE PLAZA, SUITE 875
CHICAGO, ILLINOIS 60636
PHONE (312) 474-7841
FAX (312) 474-6099

2416 GALEN DRIVE
CHAMPAIGN, ILLINOIS 61821
PHONE (217) 351-6258
FAX (217) 355-1902

A.J. ANTUNES & COMPANY

TITLE: **EQUIPMENT PAD EXHIBIT
180 KEHOE AVENUE
CAROL STREAM, IL**

SCALE: 1"=40'
DATE: 12/21/16
JOB NO: 151108A
SHEET 1 of 1

EXHIBIT A

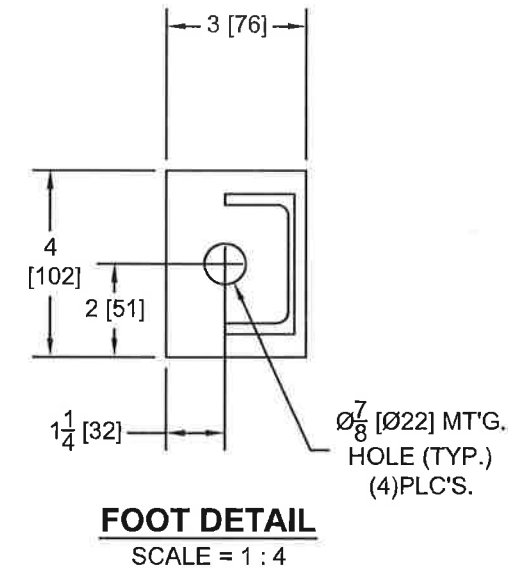
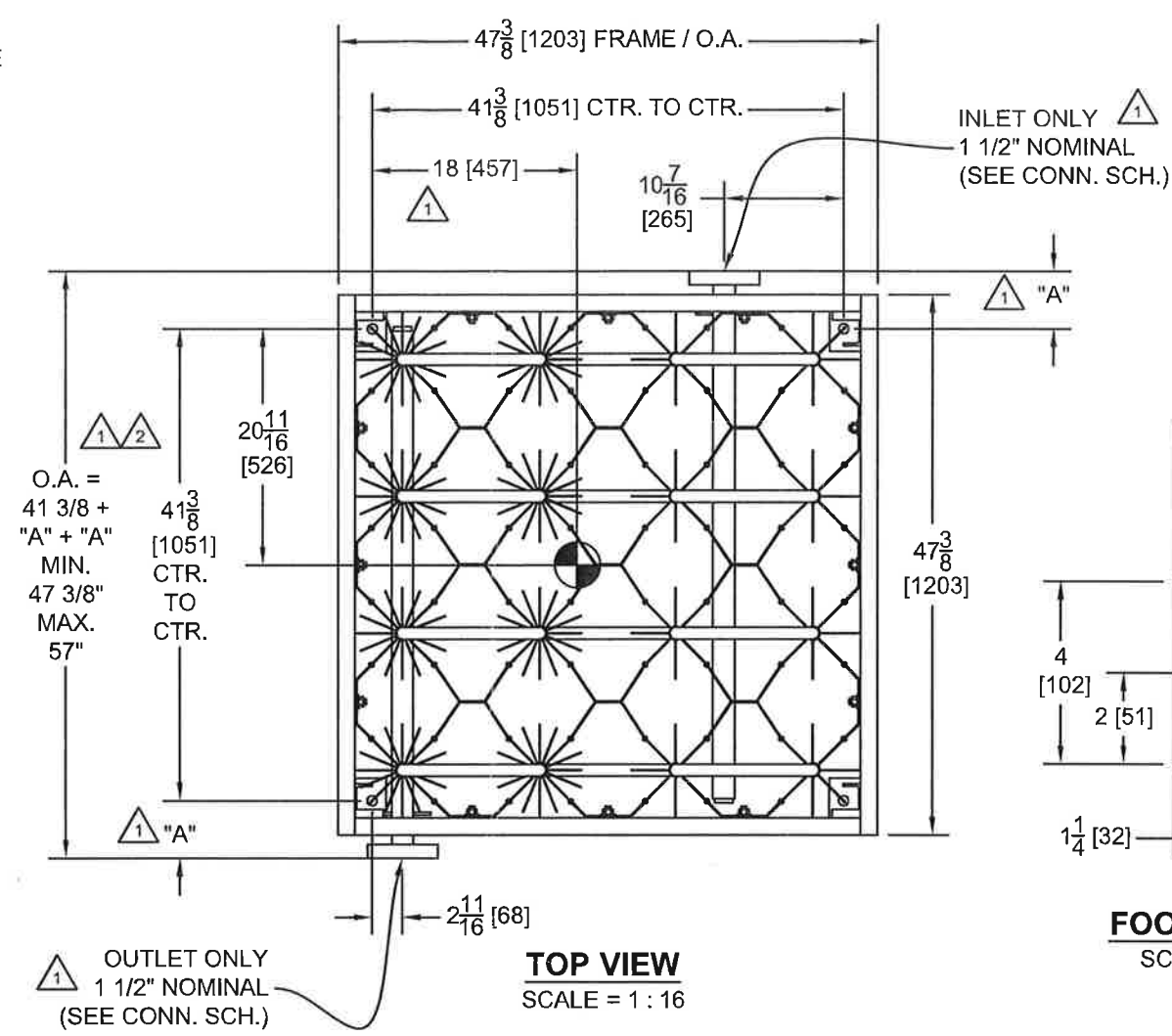
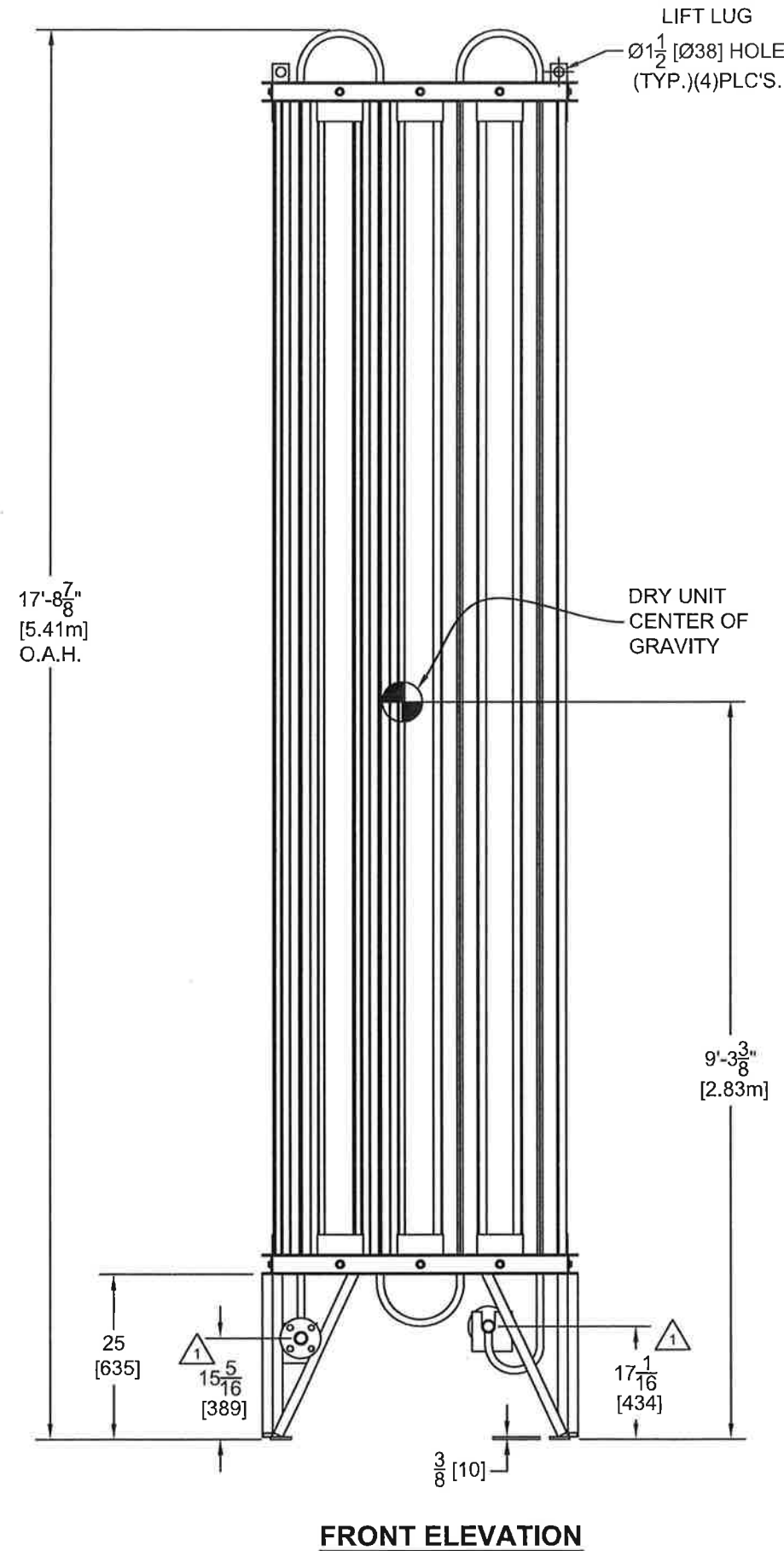

GENERAL NOTES:

- CLEAN FOR: _____ OXYGEN SERVICE
- DESIGN TEMPERATURE: _____ -320°F TO 150°F [-196°C TO 66°C]
- DESIGN PRESSURE: _____ (SEE CONNECTION SCHEDULE)
TEST PRESSURE: _____ (SEE CONNECTION SCHEDULE)
- APPROX. UNCRATED SHIPPING WEIGHT: _____ 990 LBS. [449 KG]
APPROX. CRATED SHIPPING WEIGHT: _____ 1,490 LBS. [676 KG]
- APPROX. UNCRATED SHIPPING DIMENSIONS: _____ 213"L x 53"W x 48"H
APPROX. CRATED SHIPPING DIMENSIONS: _____ 218"L x 59"W x 57"H
(SHIPPING DIMENSIONS MAY VARY BASED ON CONNECTION & SHIPPING OPTIONS)
- MATERIAL OF CONSTRUCTION: _____ 6000 SERIES ALUMINUM STRUCTURE AND FINS/
6000/3000 SERIES ALUMINUM WETTED PARTS
- ADDITIONAL PIPING/INTERCONNECTING HEADER(S) MUST NOT EXERT LOADS ON VAPORIZER NOZZLES AS THE CONTRACTION OF THE HEADER WILL BEND/DISTORT/CRACK VAPORIZER NOZZLES AND/OR LEGS

US 1 1/2" NOMINAL CONNECTION SCHEDULE - AVAILABLE OPTIONS

CONNECTION TYPE	DESIGN PRESSURE PSIG (BARG)		CONNECTION TYPE	TEST PRESSURE PSIG (BARG)	
	"A"	"A"		"A"	"A"
MNPT (MALE)(STD)	600 [41]	660 [46]	BUTT WELD (I.P.S.)	600 [41]	660 [46]
150# F.F./S/O FLANGE	275 [19]	303 [21]	F.N.P.T. (FEMALE)	600 [41]	660 [46]
150# R.F./S/O FLANGE	275 [19]	303 [21]	SOCKET WELD (I.P.S.)	600 [41]	660 [46]
300# F.F./S/O FLANGE	450 [31]	495 [34]	150# S.S. LAP JOINT	275 [19]	303 [21]
300# R.F./S/O FLANGE	450 [31]	495 [34]	FLG. W/ALUM. STUB END	600 [41]	660 [46]
MUELLER FLANGES W/ 1-5/8" SOLDER O.D.	450 [31]	495 [34]	300# S.S. LAP JOINT	600 [41]	660 [46]
			FLG. W/ALUM. STUB END	600 [41]	660 [46]

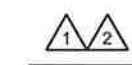

This product and / or data was designed and/or developed by Thermax Inc. and shall not be used in any way injurious to the interests of Thermax Inc.

Thermax Inc.
540 Hawthorn St., Dartmouth, MA 02747

TITLE
8" Thermafin/Megafin Supergap Hybrid Ambient Vaporizer
TMF1615A-HF-SG
(Ref. AL2500HF)

SCALE: 1 : 24	DR. BY: JEJ	CK. BY: JEJ	CUSTOMER DRAWING
DATE: 3/27/2007	QC:	SHT OF 1 1	CUSTOM

2	10/21/2009	JEJ	JEJ
1	11/5/2008	JEJ	JEJ
REV.	DATE	DR. BY	CK. BY

WARNING
 AGA, ASME or Other Manual A/C Technical Data for Required Safety Procedures Should be Done Only by Experienced Personnel. Refer to Appropriate NFPA, CGA, Handling Procedures, etc. Chryogenic and/or Flammable Fluids and Equipment.
 JOB NO: **F10989-23**
 REV: **2**
 DWG. NO: **L519-16-15-13**

TRIFECTA®-X15

LASER ASSIST GAS SUPPLY SYSTEM

The Trifecta® X15 is the preferred solution for reliable and continuous laser assist gases for delivery pressures up to 450 psi and flow rates up to 15,000 scfh. Drawing liquid from a standard bulk tank, the Trifecta system boosts the liquid pressure by alternately feeding two liquid cylinders equipped with innovative multi-function pressure building vaporizers. The Trifecta solution has no down-time and minimal losses when compared with other laser gas solutions. This convenient solution eliminates high-pressure pumps, compressors, cylinder cradles and surge tanks.



Model X15



Visual Indication for Operation Modes



Integrated Bulk Tank Pressure Sensor



Dual Relief Valve Assembly



Two Main Connections Simplify Installation

PRODUCT HIGHLIGHTS

- System utilizes standard low-pressure bulk tank to lower investment and use existing assets
- No downtime – system maintains pressure and flow when bulk tank is filled and eliminates excessive product losses associated with high-pressure bulk tanks
- Cylinders switch by pressure instead of level to further reduce product loss and protect against pressure decay
- Robust design features streamlined all stainless steel piping with only five control valves and one integrated electronic control system (PLC) for increased durability and reliability
- Computer-controlled design simplifies installation, start-up and continuous operation
- Frame assembly features a protective top cover in a compact footprint with an elevated base for improved ventilation



Innovation. Experience. Performance.™

TRIFECTA[®]-X15

LASER ASSIST GAS SUPPLY SYSTEM

SIMPLIFIED STAINLESS STEEL PLUMBING WITH PROTECTIVE TOP COVER



System Requirements

- 15 amp, 110 VAC power, dedicated circuit
- Bulk storage tank with 50 psig minimum pressure
- External vaporizer, minimum 550 psig working pressure, sized for maximum flow rate
- Two piping connections to bulk storage tank (liquid withdrawal & low phase instrument line)
- High-flow pressure regulation

Dimensions

Length	53"	1347 mm
Width	55"	1400 mm
Height	96"	2440 mm
Weight	1800 lbs	815 kg

NEW MODEL TRIFECTA X15

TRIFECTA X15 Up to 15,000 scfh at 450 psig (394 Nm³H at 31 bar)

- Automated pressure building system for *high flow* and improved reliability
- Onboard Diagnostics System
- Utilizes HP² Technology

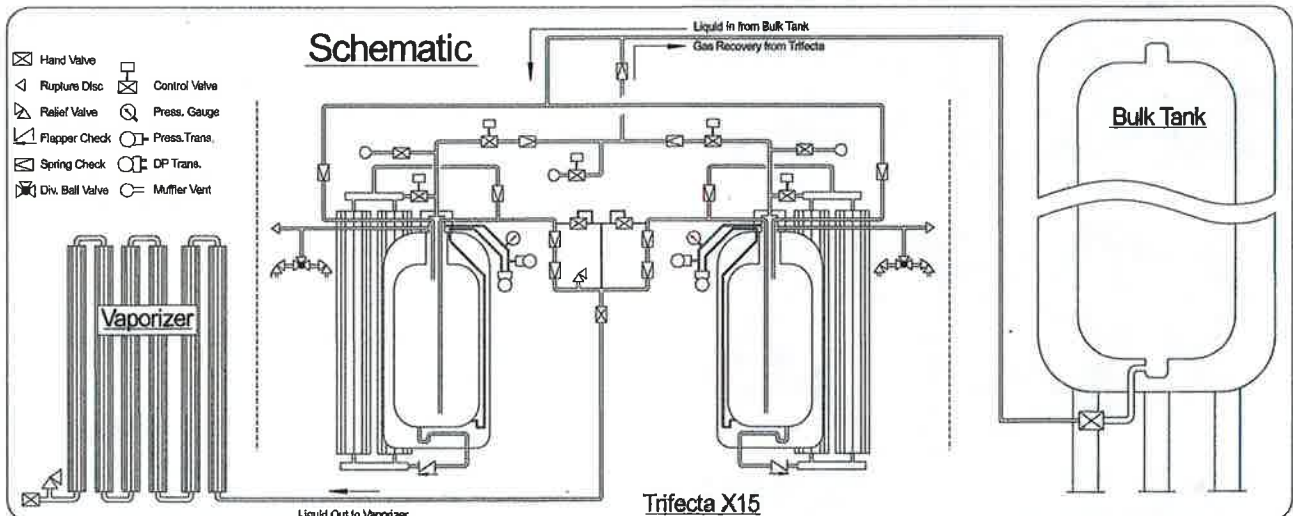
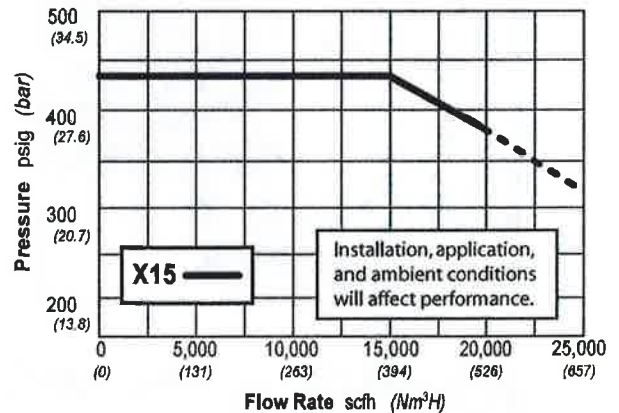

PATENT NUMBERS 5,924,291 - 5,937,655 - 5,121,609 - 5,231,838 - 6,542,848 - 6,782,339 - other patents pending.

Chart Inc.
U.S.: 1-800-400-4683
Worldwide: 1-952-758-4484



© 2010 Chart Inc.
P/N 13103412
www.chart-ind.com

EXHIBIT C

Village of Carol Stream
Interdepartmental Memo

TO: Village Board
VIA: Joe Breinig

FROM: E. Sailer

DATE: February 28, 2017

RE: Intergovernmental Agreement with Glendale Heights PD to use their Holding Facility

For the purposes of allowing Carol Stream Police Officers access and use of the Holding Facility at the Glendale Heights Police Department during our renovation project, an Intergovernmental Agreement is requested.

As part of the agreement, our officers will receive training in, and abide by, the Glendale Heights Police Department policies and procedures pertaining to the use of their holding facility, their interview rooms, and their Records Administration security and access.

I recommend the Board approve the attached Intergovernmental Agreement.

RESOLUTION NO. _____

**A RESOLUTION AUTHORIZING THE EXECUTION OF AN
INTERGOVERNMENTAL AGREEMENT BY AND BETWEEN THE VILLAGE OF
CAROL STREAM AND THE VILLAGE OF GLENDALE HEIGHTS**

WHEREAS, the Mayor and Board of Trustees of the Village of Carol Stream have determined that it is in the best interest of the Village to execute an Intergovernmental Agreement with the Village of Glendale Heights for use of the Village of Glendale Heights' Police Department Facilities as attached hereto as Exhibit "A", and by this reference incorporated herein.

NOW, THEREFORE, BE IT RESOLVED BY THE MAYOR AND BOARD OF TRUSTEES OF THE VILLAGE OF CAROL STREAM, DUPAGE COUNTY, ILLINOIS, IN THE EXERCISE OF ITS HOME RULE POWERS, as follows:

SECTION 1: That the Mayor and Village Clerk of the Village of Carol Stream be and the same are hereby authorized to execute the Agreement, in the appropriate form, attached hereto as Exhibit "A".

SECTION 2: That all Resolutions or parts thereof, in conflict with the provisions of this Resolution are, to the extent of such conflict, expressly repealed.

PASSED AND APPROVED THIS 6th DAY OF MARCH, 2017.

AYES:

NAYS:

ABSENT:

Frank Saverino, Sr., Mayor

ATTEST:

Laura Czarnecki, Village Clerk

**INTERGOVERNMENTAL AGREEMENT BETWEEN THE VILLAGE OF CAROL
STREAM AND THE VILLAGE OF GLENDALE HEIGHTS REGARDING THE USE OF
THE VILLAGE OF GLENDALE HEIGHTS' POLICE DEPARTMENT FACILITIES**

THIS AGREEMENT is entered into by and between the Village of Carol Stream ("Carol Stream") and the Village of Glendale Heights ("Glendale Heights")

WITNESSETH:

WHEREAS, The Villages of Glendale Heights and Carol Stream are home rule municipalities, and pursuant to the Illinois Constitution, Article VII, Section 8, are authorized to execute this Agreement; and

WHEREAS, Section 10 of Article VII of the Constitution of the State of Illinois and the Intergovernmental Cooperation Act, 5 ILCS 220/1 et. seq., allow and encourage intergovernmental cooperation; and

WHEREAS, the Villages of Carol Stream and Glendale Heights agree that it would be in the best interests of their citizens to allow Carol Stream to use certain facilities located at the Glendale Heights Police Department; and

WHEREAS, Carol Stream is desirous of protecting Glendale Heights from liability in consideration of the grant of the use of certain facilities located at the Glendale Heights Police Department.

NOW, THEREFORE, in consideration of the mutual agreements contained in this Agreement, the Village of Carol Stream and the Village of Glendale Heights hereby agree as follows:

SECTION 1. The Carol Stream Police Department may transport any individuals that have been arrested to the Glendale Heights Police Department for the purpose of processing the arrestee as provided in this Agreement.

SECTION 2. The Carol Stream Police Department may transport persons to the Glendale Heights Police Department and process arrestees pursuant to the following terms and conditions:

A. Carol Stream agrees to be responsible for the transportation of its arrestees to and from the Glendale Heights Police Department for the purpose of processing an arrest.

B. Carol Stream agrees to be responsible for damages caused by its arrestees to Glendale Heights Police Department property.

C. To the fullest extent permitted by law, Carol Stream shall save, indemnify and hold harmless Glendale Heights, its officers, officials, agents and employees from any liability, or claim of liability for injury or damages to persons or property or both, sustained or claimed to have been sustained by anyone whomsoever, arising out of the negligent operation, use or occupancy of facilities located at the Glendale Heights Police Department or any adjoining or related facilities, premises or areas by Carol Stream, its officers, officials, agents and employees. However, Carol Stream shall not be required to indemnify Glendale Heights for loss, damages, liability, costs or expenses incident thereto caused by the willful and wanton act of Glendale Heights. Carol Stream shall similarly protect, indemnify and hold and save harmless Glendale Heights against and from any and all claims, costs, causes, actions and expenses, including but not limited to, reasonable legal fees, incurred by reason of Carol Stream's breach of any of its obligations under, or Carol Stream's default of, any provision of this Agreement.

D. Carol Stream shall provide all services necessary for processing an arrestee, and if necessary, the bonding out of releasing of all arrestees processed by Carol Stream at the Glendale Heights Police Department.

E. Glendale Heights agrees to allow Carol Stream access to and use of their live scan equipment for the fingerprinting of arrestees processed by Carol Stream at the Glendale Heights Police Department.

F. Carol Stream officers shall abide by Glendale Heights Police Department policies covered under the following General Orders: #3200 Holding Facility-Temporary Detention, #3210 Holding Facility-Training, Access and Security, #3220 Holding Facility- Physical Condition, #3230 Holding Facility- Security and Control, #3250 Holding Facility-Detainee Health and Medical Care, #3240 Detainee Processing. Copies of these policies shall be provided to Carol Stream upon passage and approval of this Agreement.

G. Glendale Heights agrees to allow Carol Stream access to and use of their interview rooms. Carol Stream officers and detectives shall abide by Glendale Heights Police Department policies covered under General Order #2035 Interview Rooms governing proper interview room usage. A copy of this policy shall be provided to Carol Stream upon passage and approval of this Agreement.

H. Carol Stream shall abide by Glendale Heights Police Department policies covered under General Order #3600 Records Administration governing access and security of the Records Section.

SECTION 3. Amendments to the terms and conditions of this Agreement may be made upon written mutual agreement of the Chief of Police of the Village of Carol Stream and the Chief of Police of the Village of Glendale Heights.

SECTION 4. The Term of this Agreement shall commence on March 1, 2017 and shall continue for an initial term of eighteen (18) months. Said term shall be automatically extended for up to four (4) additional one (1) month periods, unless Carol Stream provides at least sixty (60) days advance notice of intent not to extend for any or all of the four (4) additional one (1) month periods.

SECTION 5. This Agreement shall become effective upon passage and approval and signature of the parties to this Agreement. This Agreement shall be construed in accordance with the laws and Constitution of the State of Illinois.

IN WITNESS WHEREOF, the Village of Carol Stream and the Village of Glendale Heights have executed this Agreement on the _____ day of _____, 2017.

**VILLAGE OF GLENDALE HEIGHTS,
an Illinois municipal corporation**

By: *Linda Jackson*
Mayor

ATTEST:

By: *Maria De Schmidt*
Village Clerk

**VILLAGE OF CAROL STREAM,
an Illinois municipal corporation**

By: _____
Mayor

ATTEST:

By: _____
Village Clerk



RESOLUTION NO. ____

**A RESOLUTION AUTHORIZING THE EXECUTION OF THE
OFFICIAL ZONING MAP OF THE VILLAGE OF CAROL STREAM**

WHEREAS, the Illinois Compiled Statutes (65 ILCS 5/11-13-19) require the corporate authorities to publish a map clearly showing the zoning classification of all land within the municipality, including all changes that occurred within the preceding calendar year, no later than March 31 of each year; and

WHEREAS, at their meeting on February 27, 2017, the Combined Plan Commission and Zoning Board of Appeals reviewed and recommended approval of the 2017 Official Zoning Map for the Village of Carol Stream.

NOW, THEREFORE, BE IT RESOLVED BY THE MAYOR AND BOARD OF TRUSTEES OF THE VILLAGE OF CAROL STREAM, DU PAGE COUNTY, ILLINOIS, IN THE EXERCISE OF ITS HOME RULE POWERS, AS FOLLOWS:

SECTION 1: That the Mayor is authorized to execute and the Village Clerk to attest **The Official Zoning Map of the Village of Carol Stream**, a map prepared using base parcel data provided by the DuPage County Mapping Department, dated March 6, 2017, such document being attached to and made a part of this Resolution.

SECTION 2: This Resolution shall be in full force and effect from and after its passage and approval as provided by law.

PASSED AND APPROVED THIS 6th DAY OF MARCH 2017.

AYES:

NAYS:

ABSENT:

Frank Saverino, Sr., Mayor

ATTEST:

Laura Czarnecki, Village Clerk

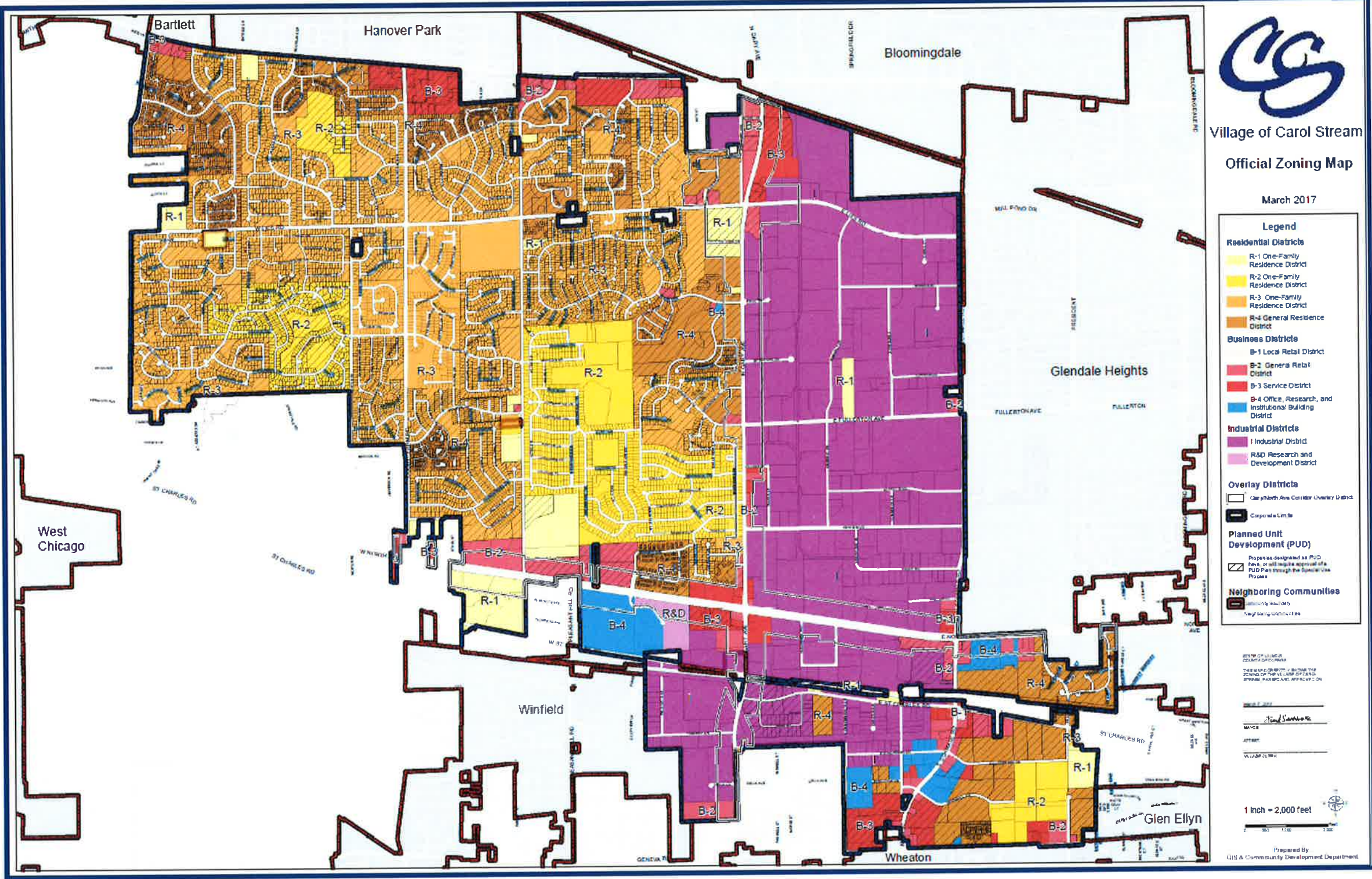

Village of Carol Stream
 Official Zoning Map

March 2017

- Legend**
- Residential Districts**
 - R-1 One-Family Residence District
 - R-2 One-Family Residence District
 - R-3 One-Family Residence District
 - R-4 General Residence District
 - Business Districts**
 - B-1 Local Retail District
 - B-2 General Retail District
 - B-3 Service District
 - B-4 Office, Research, and Institutional Building District
 - Industrial Districts**
 - I Industrial District
 - R&D Research and Development District
 - Overlay Districts**
 - Carleth Ave Corridor Overlay District
 - Corporate Limits
 - Planned Unit Development (PUD)**
 - Properties designated as PUD. PUDs require approval of the PUD Plan through the Special Use Process.
 - Neighboring Communities**
 - Neighboring Municipalities
 - Neighboring Counties

BY THE VILLAGE CLERK
 COUNTY OF DUKEWAY

THIS MAP IS NOT TO BE USED FOR THE PURPOSES OF THE VILLAGE OF CAROL STREAM ZONING MAP AND APPROVAL OF THE ZONING MAP AND APPROVAL OF THE ZONING MAP.

DATE: 3/17/17

PREPARED BY: *[Signature]*

TITLE: OFFICIAL ZONING MAP

VILLAGE CLERK: _____

1 inch = 2,000 feet

Prepared By:
 GIS & Community Development Department

Village of Carol Stream
Interdepartmental Memo

TO: Joseph Breinig, Village Manager
FROM: Rose Armstrong, Administration Secretary 
DATE: February 23, 2017
RE: Carol Stream Rotary Club's Chili Open
Raffle License Application – Fee Waiver

The Carol Stream Rotary Club is holding their annual Chili Open and requests approval to conduct a raffle drawing at their banquet on Friday, May 12, 2017 to be held at the Bartlett Hills Golf Club. Raffle tickets will be sold from March 01, 2017 – May 12, 2017 for \$5.00 per ticket or three for \$10.00. The Rotary Club has also submitted the attached letter respectively requesting a waiver of the license fee.

Please place this request on the agenda for Monday, March 6, 2017 for the Board's review and approval. The raffle license application and required documentation is on file in the Village Clerk's office for your review.

Thank you.

Attachment

Robert A. McNees

Lisa K. Murphy

Attorneys at Law

195 Hiawatha Drive
Carol Stream, IL 60188

Phone (630) 665-8811

Fax (630) 665-5260

Info@McNeesAssociates.com

February 21, 2017

Mayor Frank Saverino
and Board of Trustees
Village of Carol Stream
500 North Gary Avenue
Carol Stream, IL 60188

RE: Carol Stream Rotary Club
Chili Open Raffle
May 12, 2017

Dear Mayor Saverino and Trustees;

Enclosed please find the Raffle License Application for the Chili Open Raffle to be held May 12, 2017. As in past years, we would appreciate it if the Village would waive its license fees in connection with the raffle.

I do not recall if we provided the Village with the results of last year's Chili Open Raffle. As you may be aware, the raffle is but one element of our fund raising efforts in the Chili Open. Last year we raised \$1,500.00 in gross raffle ticket sales. We gave out \$850.00 to raffle winners. Attached is the Reporting Form for last year's account.

Using the total Chili Open proceeds, we set aside \$5,000.00 to donate to: 1) the Carol Stream Veterans Memorial Park; and 2) Kids Against Hunger-Fox Valley. We also used the total proceeds to help support Rotary charitable causes such as Carol Stream Christmas sharing, Glenbard North Post Prom, and collegiate scholarships.

This year, the funds raised will be donated to Rotary charitable causes and to the Synergy Adaptive Sports Program, a WDSRA and NEDSRA partnership, and the DuPage Legal Assistance Foundation.

Our renewal bond has been filed with the Village.

Thank you for your anticipated cooperation and assistance in this matter.

Very truly yours,

McNees & Associates, LLC

By: 
Robert A. McNees

RAM/sld
Enclosure

**Village of Carol Stream
Schedule of Bills
For Village Board Approval on March 6, 2017**

AGENDA ITEM
L-1 3-6-17

<u>Vendor / Description</u>	<u>Amount</u>	<u>Account Number</u>	<u>Account Description</u>	<u>Invoice No.</u>	<u>Purchase Order</u>
B & F CONSTRUCTION CODE SERVICES, INC					
PLUMBING INSP'S JAN/2017	958.40	01643700-52253	CONSULTANT	45916	
	<u>958.40</u>				
BAXTER & WOODMAN INC					
WRC NPDES COMPLIANCE STUD 1/15- 2/11	3,102.95	04101100-52253	CONSULTANT	0190874	20170006
WTR MODEL RELATED TO DERMODY DEV	2,252.50	04201600-52253	CONSULTANT	01090875	
	<u>5,355.45</u>				
BRIAN CLUEVER					
PER DIEM FOR TRNG 03/12 THRU 05/19	3,360.00	01662700-52223	TRAINING	NWU-EVANSTON	
	<u>3,360.00</u>				
BRIAN COOPER					
TUITION REIMB CLS 2/15/2017	484.00	01662300-52223	TRAINING	2/15/2017 TUITION	
	<u>484.00</u>				
CAROL STREAM PARK DISTRICT					
JAN-FEB BARK PARK PAYMENTS	60.00	01-24236	BARK PARK MEMBERSHIP	JAN-FEB BARK PRK	
	<u>60.00</u>				
CARTEGRAPH					
ANNUAL LICENSE -OPER MGMT SYSTEMS SOFTW	2,289.40	04100100-52255	SOFTWARE MAINTENANCE	SIN002822	
ANNUAL LICENSE -OPER MGMT SYSTEMS SOFTW	2,289.41	04200100-52255	SOFTWARE MAINTENANCE	SIN002822	
ANNUAL LICENSE -OPER MGMT SYSTEMS SOFTW	4,578.81	01622200-52255	SOFTWARE MAINTENANCE	SIN002822	
ANNUAL LICENSE -OPER MGMT SYSTEMS SOFTW	22,894.03	01-13010	PRE-PAID ITEMS	SIN002822	
ANNUAL LICENSE -OPER MGMT SYSTEMS SOFTW	22,894.03	04-13010	PRE-PAID ITEMS	SIN002822	
OPER'S MGMT SYSTEMS SOFTWARE SRV'S 1 OF 4	6,368.75	04100100-52255	SOFTWARE MAINTENANCE	SIN002829	
OPER'S MGMT SYSTEMS SOFTWARE SRV'S 1 OF 4	6,368.75	04200100-52255	SOFTWARE MAINTENANCE	SIN002829	
OPER'S MGMT SYSTEMS SOFTWARE SRV'S 1 OF 4	12,737.50	01622200-52255	SOFTWARE MAINTENANCE	SIN002829	
	<u>80,420.68</u>				

**Village of Carol Stream
Schedule of Bills
For Village Board Approval on March 6, 2017**

<u>Vendor / Description</u>	<u>Amount</u>	<u>Account Number</u>	<u>Account Description</u>	<u>Invoice No.</u>	<u>Purchase Order</u>
CARYL REBHOLZ					
REIMBURSEMENT FOR EMPLOYEE EVENT	118.86	01600000-52242	EMPLOYEE RECOGNITION	SUPERBOWL CELEB	
	<u>118.86</u>				
CHECKPOINT PRESS					
AD FOR CST POSITION	298.00	01600000-52228	PERSONNEL HIRING	35127	
	<u>298.00</u>				
CITY OF ST CHARLES					
RANGE FEE MAY/2017-APRIL/2018	500.00	01-13010	PRE-PAID ITEMS	IN4565	
	<u>500.00</u>				

**Village of Carol Stream
Schedule of Bills
For Village Board Approval on March 6, 2017**

<u>Vendor / Description</u>	<u>Amount</u>	<u>Account Number</u>	<u>Account Description</u>	<u>Invoice No.</u>	<u>Purchase Order</u>
COMED					
ELECTRICAL SRV'S 505 E NORTH AVE	8,706.73	01680000-55487	FACILITY CAPITAL IMPROVEMENT	ACT#6888091045	
1 N END THORNHILL	74.40	01670300-53213	STREET LIGHT ELECTRICITY	6337409002 2/17/17	
1015 LIES RD TOWER #4	83.36	04201600-53210	ELECTRICITY	2514004009 2/17/17	
1025 LIES RD CONTROLLER	304.87	01670300-53213	STREET LIGHT ELECTRICITY	6213120002 2/17/17	
106 GOLDENHILL AERATOR	31.66	01670600-53210	ELECTRICITY	2127117053 02/23/17	
1128 EVERGREEN TRL	65.21	04101500-53210	ELECTRICITY	0291093117 02/21/17	
1345 GEORGETOWN DR	35.92	01670300-53213	STREET LIGHT ELECTRICITY	1603109101 01/24/17	
1345 GEORGETOWN DR	27.46	01670300-53213	STREET LIGHT ELECTRICITY	1603109101 02/22/17	
1350 TALL OAKS DR	49.23	04101500-53210	ELECTRICITY	2073133107 02/20/17	
1415 MAPLE RIDGE CT PUMP	31.66	01670600-53210	ELECTRICITY	5838596003 02/21/17	
192 YUMA LN	83.44	01670300-53213	STREET LIGHT ELECTRICITY	0501137042 02/20/17	
301 ANTELOPE TRL	77.71	01670300-53213	STREET LIGHT ELECTRICITY	0801065136 02/20/17	
333 FULLERTON AVE	1,195.46	04201600-53210	ELECTRICITY	0300009027 02/21/17	
391 FLINT TRL	63.69	01670300-53213	STREET LIGHT ELECTRICITY	2207156029 02/20/17	
391 ILLINI DR PUMP	138.90	01670600-53210	ELECTRICITY	4430145023 02/20/17	
401 TOMAHAWK CT	131.50	01670300-53213	STREET LIGHT ELECTRICITY	0723076266 02/20/17	
403 SIOUX LN	26.21	01670300-53213	STREET LIGHT ELECTRICITY	1353117013 02/21/17	
451 N SILVERLEAF BLVD	50.14	01670300-53213	STREET LIGHT ELECTRICITY	0030086009 02/20/17	
491 CHEYENNE TRL	25.86	01670300-53213	STREET LIGHT ELECTRICITY	6597112015 02/21/17	
500 N GARY AVE LITE RT/25	101.16	01670300-53213	STREET LIGHT ELECTRICITY	6675448009 02/20/17	
506 CHEROKEE CT	56.47	01670300-53213	STREET LIGHT ELECTRICITY	3153036011 02/20/17	
512 CANYON TRL	24.07	01670300-53213	STREET LIGHT ELECTRICITY	1043062112 2/21/17	
594 NEZ PERCE CT	76.31	01670300-53213	STREET LIGHT ELECTRICITY	0975048036 2/21/17	
633 THUNDERBIRD TRL	246.80	01670300-53213	STREET LIGHT ELECTRICITY	0455095075 02/20/17	
796 PAWNEE DR	65.75	01670300-53213	STREET LIGHT ELECTRICITY	2264121040 02/20/17	
850 LONGMEADOW DR AERATOR	21.33	01670600-53210	ELECTRICITY	1865134015 02/20/17	
879 DORCHESTER DR AERATOR	21.33	01670600-53210	ELECTRICITY	0803155026 2/20/17	
880 PAPOOSE CT	137.51	01670300-53213	STREET LIGHT ELECTRICITY	0822115042 02/20/17	
990 DEARBORN CIR	71.84	01670300-53213	STREET LIGHT ELECTRICITY	3480136046 02/20/17	
MASTER ACCOUNT	2,049.95	01670300-53213	STREET LIGHT ELECTRICITY	5853045025 02/22/17	

**Village of Carol Stream
Schedule of Bills
For Village Board Approval on March 6, 2017**

<u>Vendor / Description</u>	<u>Amount</u>	<u>Account Number</u>	<u>Account Description</u>	<u>Invoice No.</u>	<u>Purchase Order</u>
RED LIGHT CAMERA- KUHN RD	39.66	01662300-52298	ATLE SERVICE FEE	4202129060 02/20/17	
SW MORTON & LIES (MASTER)	197.98	01670300-53213	STREET LIGHT ELECTRICITY	0815164035 02/28/17	
	<u>14,313.57</u>				
COMPASS MINERALS AMERICA INC					
FY 16/17 ROCK SALT PROVIDER	14,358.53	01670200-53335	SALT	71609557	20170009
	<u>14,358.53</u>				
CONSTELLATION NEW ENERGY					
200 TUBEWAY LIFT STN	420.14	04101500-53210	ELECTRICITY	00379158510001	
	<u>420.14</u>				
CRYSTAL MGMT & MAINTENANCE SRV'S CORP					
CLEANING SERVICES MAR/2017	860.00	01670100-52276	JANITORIAL SERVICES	24389	
CLEANING SERVICES MAR/2017	1,385.00	01680000-52276	JANITORIAL SERVICES	24389	
	<u>2,245.00</u>				
DAVID G BAKER					
VETERAN'S PRODUCTION SERVICE	165.00	01590000-52253	CONSULTANT	022217	
	<u>165.00</u>				
DUPAGE COUNTY RECORDER					
WEED LIEN REC- 885 SHENANDOAH DR	8.00	01580000-52233	RECORDING FEES	201702030136	
	<u>8.00</u>				
DUPAGE WATER COMMISSION					
WATER PURCH JAN/17	487,718.40	04201600-52283	DUPAGE CTY WATER COMMISSION	1632	
	<u>487,718.40</u>				
ENGINEERING RESOURCE ASSOCIATES INC					
KLEIN CREEK STRM BNK STABILIZAT THRU JAN 27	8,946.30	11740000-55488	STORMWATER UTILITIES	160914.04	20170027
	<u>8,946.30</u>				

**Village of Carol Stream
Schedule of Bills
For Village Board Approval on March 6, 2017**

<u>Vendor / Description</u>	<u>Amount</u>	<u>Account Number</u>	<u>Account Description</u>	<u>Invoice No.</u>	<u>Purchase Order</u>
EXAMINER PUBLICATIONS INC					
BID NTC- MOVERS	112.50	01680000-55487	FACILITY CAPITAL IMPROVEMENT	40263	
	<u>112.50</u>				
GOVTEMPSUSA LLC					
OFFICE MGR W/E 02/05	1,461.60	01590000-52253	CONSULTANT	2187255	
OFFICE MGR W/E 02/12	1,461.60	01590000-52253	CONSULTANT	2187256	
	<u>2,923.20</u>				
HD SUPPLY WATERWORKS LTD					
10" VALVE REPLACEMENT	2,573.97	04201600-52244	MAINTENANCE & REPAIR	G749809	
CREDIT FOR PARTS	-1,972.17	04201600-52244	MAINTENANCE & REPAIR	G755340	
VALVE REPAIR 365 NORTH AVE	2,633.20	04201600-52244	MAINTENANCE & REPAIR	G748274	
	<u>3,235.00</u>				
INFRASTRUCTURE MANAGEMENT SERVICES					
PAVEMENT EVALUATION	4,887.50	11740000-55486	ROADWAY CAPITAL IMPROVEMENT	14016-4	20170029
	<u>4,887.50</u>				
KLEIN, THORPE & JENKINS, LTD					
LEGAL SERVICES - JAN/2017	21.00	21500000-52238	LEGAL FEES	187252 2/14/17	
LEGAL SERVICES - JAN/2017	63.00	11740000-52238	LEGAL FEES	187252 2/14/17	
LEGAL SERVICES - JAN/2017	1,218.00	04100100-52238	LEGAL FEES	187252 2/14/17	
LEGAL SERVICES - JAN/2017	3,759.00	11740000-55490	VILLAGE HALL RENOVATION	187252 2/14/17	
LEGAL SERVICES - JAN/2017	8,336.50	01570000-52238	LEGAL FEES	187252 2/14/17	
	<u>13,397.50</u>				
KONEMATIC INC					
NORTH GARAGE DOOR REPAIR	1,600.00	01670400-52244	MAINTENANCE & REPAIR	835032	
	<u>1,600.00</u>				

**Village of Carol Stream
Schedule of Bills
For Village Board Approval on March 6, 2017**

<u>Vendor / Description</u>	<u>Amount</u>	<u>Account Number</u>	<u>Account Description</u>	<u>Invoice No.</u>	<u>Purchase Order</u>
MARK DUNTEMANN					
TRAINING 4/4/17 PAULING, TECHTER	350.00	01670700-52223	TRAINING	2017-07	
	350.00				
MTI CONSTRUCTION SERVICES, LLC					
TEMPORARY FACILITY FOR VLG HL & POLICE	-9,460.00	01-21342	RETAINAGE MTI CONSTRUCTION S17-006		
TEMPORARY FACILITY FOR VLG HL & POLICE	113,561.72	01680000-55487	FACILITY CAPITAL IMPROVEMENT 17-006		
	104,101.72				
OFFICE DEPOT					
DUPL FALSE ALRM PAYMENT REFUNDS	150.00	01000000-45420	FALSE ALARMS - FINES	FA15191 & FA15560	
	150.00				
PERSPECTIVES					
EAP SERVICES MARCH MARCH THRU MAY	1,149.72	01600000-52273	EMPLOYEE SERVICES	85983	
	1,149.72				
PETTY CASH					
PETTY CASH REIMBURSEMENTS	600.98	01-10307	PETTY CASH	MARCH/2017	
	600.98				
PIONEER TIRE REPAIR					
SUPPLIES	182.44	01696200-53317	OPERATING SUPPLIES	2222	
	182.44				
PUSH WELLNESS SOLUTIONS INC					
WELLNESS INCENTIVES- MARCH	2,566.00	01600000-52340	WELLNESS PROGRAM	160730	
	2,566.00				
RAY O'HERRON CO					
AMMUNITION	5,280.00	01662700-53321	AMMUNITION	1705569-IN	
	5,280.00				

**Village of Carol Stream
Schedule of Bills
For Village Board Approval on March 6, 2017**

<u>Vendor / Description</u>	<u>Amount</u>	<u>Account Number</u>	<u>Account Description</u>	<u>Invoice No.</u>	<u>Purchase Order</u>
REFUNDS MISC					
FIRE ALRM INSPECTION REFUND	3,377.44	01000000-42307	BUILDING PERMITS	700 KIMBERLY(1)	
PERMIT# 15-99-1443 FIRE ALRM INSP REFUND	3,292.80	01000000-42307	BUILDING PERMITS	191 E NORTH AVE	
SEWER INSPECTION REFUND	1,000.00	01-24324	SANITARY SEWER CONNECTION SE1N542 GOLFVIEW		
SEWER INSPECTION REFUND	1,000.00	01-24324	SANITARY SEWER CONNECTION SE1N644 FISHER LN		
TICKET WAS VOIDED, PAYMENT REFUNDED	100.00	01000000-45402	ORDINANCE FORFEITS	TICKET 234890	
	8,770.24				
REFUNDS PRESERVATION BONDS					
SUN ROOM & PATIO BOND REFUND	200.00	01-24302	ESCROW - GRADING	789 BERKSHIRE	
SUNROOM BOND REFUND	200.00	01-24302	ESCROW - GRADING	574 EDGEBROOK	
	400.00				
REFUNDS W&S FINALS					
350 RANDY RD #6 W&S REFUND	8.90	04-12110	ACCOUNT RECEIV WATER & SEWER	20719	
W&S FINAL 445 KILKENNY CT	20.28	04-12110	ACCOUNT RECEIV WATER & SEWER	2034	
W&S FINAL 449 CANYON TRL	40.76	04-12110	ACCOUNT RECEIV WATER & SEWER	1736	
W&S FINAL REFUND 480 ARROWHEAD	42.83	04-12110	ACCOUNT RECEIV WATER & SEWER	0451	
	112.77				
SANTACRUZ ASSOCIATES LTD					
LAND ACQUISITION SRV'S	5,400.00	04201600-54480	CONSTRUCTION	2210	20170034
	5,400.00				
TIF 3 NORTH AND SCHMALE RD					
TIF3 SALES TAX TRANSFER	-31,324.96	22000000-49340	SALES TAX CONTRIB - RDA#1	TIF3 SALES TRNFR	
TIF3 SALES TAX TRANSFER	31,324.96	01720000-58340	SALES TAX TFR - RDA#1	TIF3 SALES TRNFR	
TIF3 SALES TAX TRANSFER	31,324.96	22-11105	CASH - TRUST	TIF3 SALES TRNFR	
	31,324.96				
TRANSYSTEMS CORPORATION					
PH 1 PRELIMINARY ENGR SRV 1/14- 02/10 2017	3,809.97	11740000-55486	ROADWAY CAPITAL IMPROVEMENT	02-3104351	20170033
	3,809.97				

**Village of Carol Stream
Schedule of Bills
For Village Board Approval on March 6, 2017**

<u>Vendor / Description</u>	<u>Amount</u>	<u>Account Number</u>	<u>Account Description</u>	<u>Invoice No.</u>	<u>Purchase Order</u>
TRI R SYSTEMS INC					
TUBEWAY- TROUBLE SHOOT	420.00	01670600-52244	MAINTENANCE & REPAIR	004325	
	<u>420.00</u>				
U S POSTMASTER					
POSTAGE 2/28/174 WATER BILLS	2,161.97	04103100-52229	POSTAGE	INV 1529 03/01/17	
POSTAGE 2/28/174 WATER BILLS	2,161.97	04203100-52229	POSTAGE	INV 1529 03/01/17	
	<u>4,323.94</u>				
VERIZON WIRELESS					
CELL PH SRV JAN 14-FEB 13 2017	38.84	01610100-52230	TELEPHONE	9780366120	
CELL PH SRV JAN 14-FEB 13 2017	38.84	01640100-52230	TELEPHONE	9780366120	
CELL PH SRV JAN 14-FEB 13 2017	38.84	01642100-52230	TELEPHONE	9780366120	
CELL PH SRV JAN 14-FEB 13 2017	38.84	01690100-52230	TELEPHONE	9780366120	
CELL PH SRV JAN 14-FEB 13 2017	58.75	01680000-52230	TELEPHONE	9780366120	
CELL PH SRV JAN 14-FEB 13 2017	76.02	01662700-52230	TELEPHONE	9780366120	
CELL PH SRV JAN 14-FEB 13 2017	76.85	01600000-52230	TELEPHONE	9780366120	
CELL PH SRV JAN 14-FEB 13 2017	77.68	01643700-52230	TELEPHONE	9780366120	
CELL PH SRV JAN 14-FEB 13 2017	177.38	01590000-52230	TELEPHONE	9780366120	
CELL PH SRV JAN 14-FEB 13 2017	231.30	04200100-52230	TELEPHONE	9780366120	
CELL PH SRV JAN 14-FEB 13 2017	231.31	04100100-52230	TELEPHONE	9780366120	
CELL PH SRV JAN 14-FEB 13 2017	279.38	01652800-52230	TELEPHONE	9780366120	
CELL PH SRV JAN 14-FEB 13 2017	296.69	01620100-52230	TELEPHONE	9780366120	
CELL PH SRV JAN 14-FEB 13 2017	345.10	01670100-52230	TELEPHONE	9780366120	
CELL PH SRV JAN 14-FEB 13 2017	2,656.08	01662700-52230	TELEPHONE	9780366120	
	<u>4,661.90</u>				
VILLAGE OF CAROL STREAM					
TWN CTR FOUNTAIN	4.76	01680000-53220	WATER	1187351/20878	
VILLAGE HALL	260.07	01680000-53220	WATER	1187349/20876	
	<u>264.83</u>				

**Village of Carol Stream
Schedule of Bills
For Village Board Approval on March 6, 2017**

<u>Vendor / Description</u>	<u>Amount</u>	<u>Account Number</u>	<u>Account Description</u>	<u>Invoice No.</u>	<u>Purchase Order</u>
WEST SUBURBAN BANK					
GRAND JURY 22690	14.75	01664700-53317	OPERATING SUPPLIES	GJ#22690	
	<u>14.75</u>				
WHEATON BANK AND TRUST					
WHEATON BANK FEES JAN/17	330.80	04103100-52256	BANKING SERVICES	7509063 JAN/17	
WHEATON BANK FEES JAN/17	330.80	04203100-52256	BANKING SERVICES	7509063 JAN/17	
WHEATON BANK FEES JAN/17	859.29	01610100-52256	BANKING SERVICES	7509063 JAN/17	
	<u>1,520.89</u>				
WILLIAMS ASSOCIATES ARCHITECTS, LTD					
SCHEMATIC DESIGN PHASE SERV'S THRU JAN/17	72,398.52	11740000-55490	VILLAGE HALL RENOVATION	0017588	20170024
	<u>72,398.52</u>				
ZONES INC					
ZONES REBATE PAYMENT	197,745.61	01720000-58207	ZONES SALES TAX REIMB	SALES TX DEC-FEB	
	<u>197,745.61</u>				
GRAND TOTAL	<u><u>\$1,091,435.27</u></u>				

The preceding list of bills payable totaling \$1,091,415.27 was reviewed and approved for payment.

Approved by:

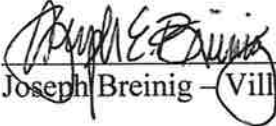

Joseph Breinig - Village Manager

Date: 3/3/17

Authorized by:

Frank Saverino Sr - Mayor

Laura Czarnecki- Village Clerk

ADDENDUM WARRANTS
Feb 22, 2017 thru Mar 6, 2017

Fund	Check #	Vendor	Description	Amount
General	A C H	Wheaton Bank & Trust	Payroll Feb 13, 2017 thru Feb 26, 2017	521,889.97
Water & Sewer	A C H	Wheaton Bank & Trust	Payroll Feb 13, 2017 thru Feb 26, 2017	<u>46,620.50</u>
				<u><u>568,510.47</u></u>

Approved this _____ day of _____, 2017

By: _____
 Frank Saverino Sr - Mayor

 Laura Czarnecki - Village Clerk