

# Village of Carol Stream

## BOARD MEETING

### AGENDA

AUGUST 7, 2023

6:00 P.M.

*All matters on the Agenda may be discussed, amended and acted upon*

#### **A. ROLL CALL AND PLEDGE OF ALLEGIANCE:**

#### **B. MINUTES:**

1. Approval of Minutes of the July 17, 2023 Village Board Meeting.

#### **C. LISTENING POST:**

1. Check Presentation to Operation Support Our Troops-America.
2. Representative Diane Blair-Sherlock – Legislative Update.
3. Addresses from Audience (3 Minutes).

#### **D. PUBLIC HEARINGS:**

#### **E. SELECTION OF CONSENT AGENDA:**

***If you are here for an item, which is added to the consent agenda and approved, the Village Board has acted favorably on your request.***

#### **F. BOARD AND COMMISSION REPORTS:**

1. Plan Commission/Zoning Board of Appeals.
  - a. 23-0030 – E.P. Doyle & Son, LLC/Bartel's Auto Clinic, 160 S. Gary Ave.  
*Special Use Permit for Auto Repair*  
*Zoning Variation for Rear Yard Setback*  
**Recommended Approval with Conditions 5-0**

#### **G. OLD BUSINESS:**

1. Proposed Amendment to Section 13-2-37 of the Village Code – Sewer Line Maintenance/Replacement.

#### **H. STAFF REPORTS AND RECOMMENDATIONS:**

1. Request to Purchase six (6) Police Department Vehicles. *Staff recommends waiving competitive bidding pursuant to Section 5-8-14 of the Village Code and purchase one (1) Ford Police Utility from Currie Motors for a total cost of \$43,277.00 and five (5) Dodge Durangos from Thomas Dodge for a total cost of \$205,787.00.*

# Village of Carol Stream

## BOARD MEETING

### AGENDA

AUGUST 7, 2023

6:00 P.M.

*All matters on the Agenda may be discussed, amended and acted upon*

2. Recommendation to Award a Contract for the Replacement of the Electronic Message Sign located at 500 N. Gary Avenue. *Staff recommends waiving competitive bidding pursuant to Section 5-8-14(M) of the Municipal Code and enter into a purchasing contract with Chicago Sign Company in the amount of \$63,295.00 for the replacement of the electronic message sign located at 500 N. Gary Avenue.*
3. Recommendation for Purchase of a Public Works Skid Steer. *Staff recommends purchasing a 2023 Bobcat S76 Skid Steer from Atlas Bobcat under Sourcewell Contract #040319-CEC in the amount of \$88,915.00 and accept \$15,250.00 for trade-in of the existing skid steer pursuant to the provisions of Section 5-8-3(B) and subsection 5-8-14(L) of the Carol Stream Code of Ordinances.*
4. Recommendation to Repair the Roof at the Public Works Center North Garage. *Staff recommends waiving competitive bidding and approving a contract from Charles Copley Roofing, Inc. for the replacement of the south half of the Public Works Center North Garage in the amount of \$41,410.00.*
5. Recommendation for Purchase of Mobile Lift Columns. *Staff recommends purchasing four (4) mobile lift columns from Safetylane Automotive Equipment under Sourcewell Contract #013020-SKI in the amount of \$67,012.61 pursuant to the provisions of Section 5-8-3(B) and subsection 5-8-14(L) of the Carol Stream Code of Ordinances.*
6. Award of Contract – 2023 Pavement Patching Contract. *Staff recommends awarding a contract to Schroeder Asphalt Services, Inc. for the 2023 Pavement Patching at the bid unit prices submitted of \$51,920.00.*
7. Award of Contract – 2023 Crackfill Project. *Staff recommends awarding a contract to SKC Construction, Inc. for the 2023 Crackfill Project at the bid unit prices submitted of \$78,148.00.*
8. Award of Contract – Klein Creek Trail, Kuhn to Thunderbird/Bennett. *Staff recommends awarding a contract to Schroeder Asphalt Services, Inc. at the contract unit prices for the estimated total price of \$99,825.00 for the Klein Creek Trail from Kuhn to Thunderbird/Bennett.*

# Village of Carol Stream

## BOARD MEETING

### AGENDA

AUGUST 7, 2023

6:00 P.M.

*All matters on the Agenda may be discussed, amended and acted upon*

#### **I. ORDINANCES:**

1. Ordinance No. 2023-08-\_\_\_\_ Amending Chapter 11, Article 2 of the Carol Stream Code of Ordinances by Decreasing the Number of Class P Liquor Licenses from 4 to 3 (7-Eleven Inc. d/b/a 7-Eleven #38850H, 425 E. Geneva Road) and Increasing the Number of Class PL Liquor Licenses from 4 to 5 (7-Eleven Inc. d/b/a 7-Eleven #38850H, 425 E. Geneva Road).
2. Ordinance No. 2023-08-\_\_\_\_ Amending Chapter 11, Article 2 of the Carol Stream Code of Ordinances by Decreasing the Number of Class A Liquor Licenses from 17 to 16 (CDT Enterprise, Inc. d/b/a Playoffs Bar & Grill, 720 E. North Avenue).
3. Ordinance No. 2023-08-\_\_\_\_ Amending Chapter 11, Article 2 of the Carol Stream Code of Ordinances by Decreasing the Number of Class V Liquor Licenses from 21 to 20 (CDT Enterprise, Inc. d/b/a Playoffs Bar & Grill, 720 E. North Avenue).
4. Ordinance No. 2023-08-\_\_\_\_, Approving a Special Use Permit for an Auto Repair and Service Facility and a Rear Yard Building Setback Variation (Bartel's Auto Clinic, 160 S. Gary Avenue). *See F.1.a.*
5. Ordinance No. 2023-08-\_\_\_\_ Amending the Carol Stream Code of Ordinances, Chapter 13, Article 2, Section 13-2-37 Sewer Line Maintenance/Replacement. *See G.1.*

#### **J. RESOLUTIONS:**

1. Resolution No. \_\_\_\_ Accepting Public Improvements and Reduction of Security for Public Improvements – Easy Street Corp, 130 Easy Street. *Recommendation to accept the Public Improvements related to 130 Easy Street and reduce the Security for Public Improvements to a maintenance period amount of \$5,170.80 (10%) for a period of one year.*
2. Resolution No. \_\_\_\_ Declaring Surplus Property owned by the Village of Carol Stream. *Staff recommends declaring Public Works equipment; chlorine analyzer and shelter coat garage surplus and be authorized to dispose of the property as proposed pursuant to the provisions of Section 5-8-15 of the Carol Stream Code of Ordinances.*

# Village of Carol Stream

## BOARD MEETING

### AGENDA

AUGUST 7, 2023

6:00 P.M.

*All matters on the Agenda may be discussed, amended and acted upon*

#### **K. NEW BUSINESS:**

1. Raffle License Application – Windsor Park Annual Benevolent Care Campaign Grand Reception. *Request for approval of a Raffle License and waiver of the fee and manager's fidelity bond for their Annual Benevolent Care Reception to be held on August 20, 2023 at the Windsor Park Campus.*

#### **L. PAYMENT OF BILLS:**

1. Regular Bills: July 18, 2023 through August 7, 2023.
2. Addendum Warrants: July 18, 2023 through August 7, 2023.

#### **M. REPORT OF OFFICERS:**

1. Mayor:
2. Trustees:
3. Clerk:

#### **N. EXECUTIVE SESSION:**

1. The appointment, employment, compensation, discipline, performance or dismissal of a specific employee – 5/ILCS 120/2 (c) (1).

#### **O. ADJOURNMENT:**

<b>LAST ORDINANCE</b>	<b>2023-07-35</b>	<b>LAST RESOLUTION</b>	<b>3317</b>
<b>NEXT ORDINANCE</b>	<b>2023-08-36</b>	<b>NEXT RESOLUTION</b>	<b>3318</b>

**REGULAR MEETING OF THE MAYOR AND BOARD OF TRUSTEES**  
**Gregory J. Bielawski Municipal Center, 500 N. Gary Avenue,**  
**Carol Stream, DuPage County, IL**

**July 17, 2023**

Mayor Frank Saverino, Sr. called the Regular Meeting of the Board of Trustees to order at 6:02 p.m. and requested that Village Clerk Julia Schwarze call the roll.

Present: Trustees Joe Anselmo, John Zalak, Rick Gieser, Mary Frusolone and Matt McCarthy, Village Clerk Julia Schwarze and Mayor Frank Saverino, Sr.

Absent: Trustee Jeff Berger

Also Present: Village Manager Bob Mellor, Assistant Village Manager Joe Carey, Assistant to the Village Manager Brianna Bacigalupo, Community Development Director Don Bastian, Finance Director Jon Batek, Director of Engineering Services Bill Cleveland, Interim Public Works Director Brad Fink, Chief of Police Bill Holmer, Human Resources Director Caryl Rebholz, Information Technology Director Marc Talavera and Village Attorney Jim Rhodes

**ROLL CALL AND PLEDGE OF ALLEGIANCE:** *All present*

**MINUTES:**

*Trustee McCarthy moved and Trustee Anselmo made the second to approve the Minutes of the June 19, 2023 Village Board Meeting. The results of the roll call vote were as follows:*

*Ayes: 5 Trustees Anselmo, Zalak, Gieser, Frusolone and McCarthy*

*Nays: 0*

*Abstain: 0*

*Absent: 1 Trustee Berger*

*The motion passed.*

**LISTENING POST:**

1. Resolution No. 3316 Honoring Joe Cotton Ford on Forty-Nine Years of Business and Service to the Carol Stream Community - *read by Trustees Gieser, McCarthy, Frusolone, Zalak and Anselmo. Trustee Gieser moved and Trustee McCarthy made the second to approve the Resolution Honoring Joe Cotton Ford on Forty-Nine Years of Business and Service to the Carol Stream Community. The results of the roll call vote were as follows:*

*Ayes: 5 Trustees Anselmo, Zalak, Gieser, Frusolone and McCarthy*

*Nays: 0*

*Abstain: 0*

*Absent: 1 Trustee Berger*

*The motion passed as Resolution No. 3316.*

2. Check Presentation to Local Food Banks from Geek Inc Comics - *Presentation of check for \$250.00 for local food banks by Andy Bachar of Geek Inc.*

3. Representative Sanalistro's Constituent of the Month for June awarded to Denise Simone - *Representative Sanalistro presented her Constituent of the Month Award to Denise Simone.*

4. Addresses from Audience (3 Minutes). *None.*

**CONSENT AGENDA:**

*Trustee Anselmo moved and Trustee Frusolone made the second to establish a Consent Agenda for this meeting. The results of the roll call vote were as follows:*

*Ayes: 5 Trustees Anselmo, Zalak, Gieser, Frusolone and McCarthy*

*Nays: 0*

*Abstain: 0*

*Absent: 1 Trustee Berger*

*The motion passed.*

*Trustee McCarthy moved and Trustee Gieser made the second to place the following items on the Consent Agenda established for this meeting. The results of the roll call vote were as follows:*

*Ayes: 5 Trustees Anselmo, Zalak, Gieser, Frusolone and McCarthy*

*Nays: 0*

*Abstain: 0*

*Absent: 1 Trustee Berger*

*The motion passed.*

*Trustee Frusolone moved and Trustee Zalak made the second to approve the Consent Agenda for this meeting by Omnibus Vote. The results of the roll call vote were as follows:*

*Ayes: 5 Trustees Anselmo, Zalak, Gieser, Frusolone and McCarthy*

*Nays: 0*

*Abstain: 0*

*Absent: 1 Trustee Berger*

*The motion passed.*

*The following items were approved on the Consent Agenda for this meeting:*

**23-0027 – Village of Carol Stream – 500 N. Gary Avenue**

*Zoning Text Amendment-Unified Development Ordinance (UDO)*

*Miscellaneous Modifications*

**Recommended Approval 4-0**

*The Village Board concurred with Plan Commission’s recommendation.*

**23-0028 – Sierra Residence – 345 Shawnee Drive**

*Fence Code Variation*

**Recommended Approval 4-0**

*The Village Board concurred with Plan Commission’s recommendation.*

**23-0029 – Owens Residence – 349 Shawnee Drive**

*Fence Code Variation*

**Recommended Approval 4-0**

*The Village Board concurred with Plan Commission’s recommendation.*

**Temporary Waivers to the Code of Ordinances – Permit fee waivers and off-premises banners for the 2023 VetBros/Carol Stream Animal Hospital Charity Dog Show:**

The Village Board approved a temporary waiver from the sign code to allow site special event banners, and a waiver of permit fees for the banners and tent subject to certain conditions for the 2023 VetBros/Carol Stream Animal Hospital Charity Dog Show to be held at the Ross Ferraro Town Center on August 6, 2023.

**Purchase of Impound Lot Storage Containers:**

The Village Board approved the purchase of two customized 8' x 40' storage containers from Container Sales Group in the amount of \$18,688.00, which will be expended to the asset forfeiture fund and will be used for overflow storage for police evidence that does not fit or cannot be safely stored in the evidence storage area located within the Municipal Center.

**Purchase of Large Water Meters and Supplies:**

The Village Board approved the purchase of large water meters and supplies from Core & Main in an amount not-to-exceed \$40,000.00 pursuant to the provisions of Section 5-8-3(B) and subsection 5-8-14(C) of the Carol Stream Code of Ordinances.

**Purchase of Automated Salt Brine Controls:**

The Village Board approved the purchase of Brine Master SC-100-R (Automated Unit) from Brine Masters under Minnesota Purchasing Agreement Contract No. 222340 in an amount not-to-exceed \$32,835.00, pursuant to the provisions of Section 5-8-3(B) and Subsection 5-8-14(L) of the Carol Stream Code of Ordinances.

**Ordinance No. 2023-07-30 Amending Chapter 11, Article 2 of the Carol Stream Code of Ordinances by Decreasing the Number of Class P Liquor Licenses from 5 to 4 (Casey's Retail Company d/b/a Casey's #6518, 870 W. Army Trail Road) and Increasing the Number of Class PL Liquor Licenses from 3 to 4 (Casey's Retail Company d/b/a Casey's #6518, 870 W. Army Trail Road):**

The Village Board approved a liquor license classification change for Casey's #6518 located at 870 Army Trail Road from a Class P liquor license to a Class PL liquor license which will allow the sale of all packaged alcohol.

**Ordinance No. 2023-07-31 Amending Chapter 11, Article 2 of the Carol Stream Code of Ordinances by Increasing the Number of Class A Liquor Licenses from 16 to 17 (Legends Pizza LLC d/b/a Legends Pizza, 158 N. Gary Avenue):**

The Village Board approved a Class A liquor license for Legends Pizza located at 158 N. Gary Avenue.

**Ordinance No. 2023-07-32 Amending Chapter 16 of the Carol Stream Code of Ordinances. (Unified Development Ordinance-Miscellaneous Modifications):**

The Village Board approved text amendments for miscellaneous modifications to the Unified Development Ordinance.



**Ordinance No. 2023-07-33 Approving a Variation to allow a six foot tall fence in the rear yard and for fencing to be located approximately 20 feet away from the rear lot line (Sierra Residence – 345 Shawnee Drive):**

*The Village Board approved a variation for 345 Shawnee Drive to allow a six foot tall fence in the rear yard and for fencing to be located approximately 20 feet away from the rear lot line.*

**Ordinance No. 2023-07-34 Approving a Variation to allow a six foot tall fence in the rear yard and for fencing to be located approximately 20 feet away from the rear lot line (Owens Residence – 349 Shawnee Drive):**

*The Village Board approved a variation for 349 Shawnee Drive to allow a six foot tall fence in the rear yard and for fencing to be located approximately 20 feet away from the rear lot line.*

**Ordinance No. 2023-07-35, An Ordinance Amending Various Sections of Chapter 10 of the Carol Stream Code of Ordinances Pertaining to Business Licensing and Regulation:**

*The Village Board approved amending various sections of Chapter 10 regarding Business Licensing and Regulation within the Carol Stream Code of Ordinances.*

**Resolution No. 3317 Declaring Surplus Property owned by the Village of Carol Stream:**

*The Village Board declared surplus designated shotguns and authorized to dispose of the property to Streichers for a credit towards purchasing additional 40mm Launchers.*

**Raffle License Application – Carol Stream Rotary Club:**

*The Village Board approved a raffle license and waived the fee and manager's fidelity bond for a raffle event at the Charity Dog Show at the Ross Ferraro Town Center on August 6, 2023.*

**Regular Bills and Addendum Warrant of Bills:**

*The Village Board approved and confirmed prior processing of payments of Regular Bills dated July 3, 2023 in the amount of \$525,415.56. The Village Board approved and confirmed prior processing of the payment of Addendum Warrant of Bills from June 20, 2023 thru July 3, 2023 in the amount of \$703,446.03.*

*The Village Board approved payment of Regular Bills dated July 17, 2023 in the amount of \$2,087,402.22. The Village Board approved the payment of Addendum Warrant of Bills from July 4, 2023 thru July 17, 2023 in the amount of \$774,271.44.*

**Treasurer's Report:**

*The Village Board received the Revenue/Expenditure Statements and Balance Sheet for the Month ended June 30, 2023.*

**NON-CONSENT AGENDA ITEMS:**

*Item K.2. Proposed Amendment to Section 13-2-37 of the Village Code – Sewer Line Maintenance/Replacement was pulled off the Consent Agenda by Trustee McCarthy in order to have a separate discussion. Staff will bring the proposed amendment with any changes back for Village Board consideration at the August 7, 2023 Board Meeting.*

**REPORT OF OFFICERS:**

*Trustee Anselmo thanked Trustee Gieser for doing a wonderful job on the Parade Committee all these years; commented on the Neighborhood Roll Calls and thanked Chief Holmer for his coordination; reported his attendance at recent ribbon-cuttings; reminded everyone of the upcoming Concert for the Troops on July 20<sup>th</sup> and the last concert of the summer on July 27<sup>th</sup>; encouraged attendance at the August 6<sup>th</sup> Charity Dog Show in which his new puppy Cooper will be competing; and reminded residents to watch their speed as they drive around town.*

*Trustee Zalak thanked Joe Cotton Ford and Geek Inc Comics for their generosity to our community; congratulated Denise Simone on her well-deserved community service award; announced the community shredding event on July 22<sup>nd</sup> at Bierman Park; and asked that we keep the military and first responders in our thoughts and prayers.*

*Trustee Gieser thanked Joe Cotton Ford and Denise Simone for all the great things they have done for our community over the years; thanked Geek Inc Comics for their generosity with the less fortunate; encouraged residents to attend the upcoming Concert for the Troops and Movie in the Park; thanked board members, staff and the police department for helping to make this year's Carol Stream parade successful; and thanked his wife Kim and all parade volunteers who have worked hard to ensure wonderful parades for our residents year after year.*

*Trustee Frusolone reported on the substantial buying power of funds raised from 50/50 raffles for food pantries; encouraged everyone to attend the Concert for the Troops to raise money for Operation Support our Troops; announced National Night Out on August 1<sup>st</sup> as a great opportunity to bring our community together; commended Public Works, the police and fire departments on their responsiveness to recent weather events; warned residents to beware of solicitor scams; and thanked the police department for diligently investigating scammers.*

*Trustee McCarthy congratulated the Joe Cotton Ford family for the well-deserved Resolution; thanked Geek Inc Comics for their generosity; congratulated Denise Simone on her well-earned community service award; commended Trustee Rick Gieser and Kim Gieser on a great job heading up the parade committee all these years; applauded Public Works and the police department for their rapid response to recent weather events; and reminded residents to stop for individuals in cross walks and look out for kids playing outside.*

*Assistant to the Village Manager Bacigalupo reported on the remaining summer event schedule; and thanked all sponsors, Village Board members, staff, Public Works and the Police Department for supporting all our events.*

*Village Clerk Schwarze thanked Trustee Gieser for his hard work on the Parade Committee all these years; thanked the Joe Cotton Ford family for their years of service to our community; thanked Geek Inc Comics for their generosity in donating to local food pantries; congratulated Denise Simone on her service award; congratulated Officer Castro on being named School Resource Officer of the Year; and reminded residents to shop and dine Carol Stream.*

*Village Attorney Rhodes read aloud a letter Chief Holmer had received from an attorney commending our police officers for their patience, kindness and dignity in dealing with a client of his while he was being placed under arrest. He reported the purchase of his very first car, a 1968 Pontiac GTO, from Joe Cotton Ford, and will never forget the great experience with this dealership. Attorney Rhodes reported that he would be on vacation next week with Carmen Forte covering in his absence.*

*Village Manager Mellor reported on the fire hydrant painting process, noting that while the primer is white, the final color of hydrants will return to high-vis chrome yellow. The program includes a total of 2,200 fire hydrants being painted at approximately 400/year over the next five years.*

*Mayor Saverino commented on the considerable amount of road construction underway, and encouraged residents to use caution in work zones; encouraged attendance at the annual Ride for John on July 29<sup>th</sup> at Town Center in support of families who have suffered loss from opioid deaths; and wished everyone a safe and happy rest of the summer.*

*At 7:32 p.m., Trustee McCarthy moved and Trustee Frusolone made the second to adjourn the meeting. The results of the roll call vote were as follows:*

*Ayes: 5 Trustees Anselmo, Zalak, Gieser, Frusolone and McCarthy*

*Nays: 0*

*Abstain: 0*

*Absent: 1 Trustee Berger*

*The motion passed.*

FOR THE BOARD OF TRUSTEES

---

Frank Saverino, Sr., Mayor

ATTEST:

---

Julia Schwarze, Village Clerk

**Regular Meeting – Plan Commission/Zoning Board of Appeals  
Gregory J. Bielawski Municipal Center, DuPage County, Carol Stream, Illinois**

***All Matters on the Agenda may be Discussed, Amended and Acted Upon  
July 24, 2023.***

Mr. Farace stated since Chairman Parisi was absent an Acting Chairman would need to be nominated. Commissioner Petella made a motion to nominate Commissioner Tucek and Commissioner Battisto seconded the motion.

Acting Chairman Tucek called the Regular Meeting of the Combined Plan Commission/Zoning Board of Appeals to order at 6:00 p.m. and directed Patty Battaglia, Planning and Permitting Assistant, to call the roll.

The results of the roll call vote were:

Present: 5 Commissioners Battisto, Meneghini, Morris, Petella, and Acting Chairman Tucek

Absent: 2 Commissioner Christopher and Chairman Parisi

Also Present: Tom Farace, Planning and Economic Development Manager; Bravo Berisha, Assistant Planner; Patty Battaglia, Planning and Permitting Assistant and a representative from County Court Reporters

**MINUTES:**

Commissioner Petella moved and Commissioner Morris seconded the motion to approve the minutes of the Regular Meeting held on May 22, 2023 and June 26, 2023.

The results of the roll call vote were:

Ayes: 5 Commissioners Battisto, Meneghini, Morris, Petella, and Acting Chairman Tucek

Nays: 0

Abstain: 0

Absent: 2 Commissioner Christopher and Chairman Parisi

The motion passed by a unanimous vote.

**PUBLIC HEARING:**

Acting Chairman Tucek asked for a motion to open the Public Hearing. Commissioner Petella moved and Commissioner Morris seconded the motion.

The results of the roll call vote were:

Ayes: 5 Commissioners Battisto, Meneghini, Morris, Petella, and Acting Chairman Tucek

Nays: 0

Abstain: 0

Absent: 2 Commissioner Christopher and Chairman Parisi

The motion passed by unanimous vote.

**Case #23-0030 – E.P. Doyle & Sons, LLC/Bartel’s Auto Clinic – 160 S. Gary Avenue**

*Special Use Permit for Auto Repair*

*Zoning Variation*

*Gary Avenue Corridor Review*

Acting Chairman Tucek swore in Mr. Tim Doyle, 1100 Wheaton Oaks Ct, Wheaton, Illinois, and asked him to provide his presentation.

Mr. Doyle stated we are missing some key members, but Ann is representing Partners and Design so if there are any questions relative to the architecture she can speak about that. We are here as the design builder and leading the effort for the Bartel family to mimic what they currently have right now at the corner of St. Charles and Gary. Their business has really taken off not only at this location but in other communities that they serve. They were the original owners of that property and developed it all except for that one acre out lot to the south. They are starting to have a parking problem because they are just too busy. They looked at a couple different options of adding on and it made the most sense, with the existing utilities and existing right-of-ways, to build another facility. The new facility will be very similar and we’ve made some improvements like a wider, deeper work base and more parking. This building will be less public driven, meaning the public won’t come into as much as the current building, and more mechanic and building service driven. We have been working with Staff very well over the last several months and we have prepared a solid proposal and have met most of the requirements they are looking for.

Mr. Berisha started the Staff Report by stating Bartels is currently at 190 S. Gary Avenue and they own the one acre parcel at 160 S. Gary Avenue where they are proposing the development of the new repair facility. It will be 8,481 square feet and the primary purpose is to accommodate the growing needs of the business, alleviate some parking restraints and better serve customers.

Staff did conduct a parking study for this facility and, based on the requirements in our UDO, this facility will have 6,656 square feet of net floor area (per the code, the requirement states one parking space for every 250 square feet of net floor area) so they will require 13 spaces and one space per service bay. There will be ten service bays in the new facility for a total of 23 required spaces. They will have 50 spaces in the new development which exceeds the maximum permitted number. This was reviewed by Staff and believe it to be necessary in order for this facility to properly function and alleviate those parking constraints.

The minimum setback for a rear yard is 20 feet in the Industrial District. Bartels is proposing to reduce that to 16 feet 6 inches in order to maximum the working space inside the building, parking spaces and accommodate the service bays correctly. Bartels has contacted the property owner directly to the west, Artlow Systems, and they have confirmed there is no opposition to the variation being granted.

Staff has reviewed and is also supportive of the variation. Access to the site will be from a driveway off Gary Avenue and a sidewalk for customers to travel between the two facilities.

The trash enclosure will be located on the northwest corner of the building and the rooftop units will not be visible due to the height of the roofline. The exterior of the building will be insulated, precast concrete panels along with color bands on the sides of the building. The style and design will mimic the existing Bartel's Auto Clinic and Staff believes it will compliment the existing building and enhance the subject property which is currently vacant.

The landscaping proposed will consist of tree and shrub groupings on every parking lot island as well as along the Gary Avenue frontage for parking lot screening. There will also be foundation landscaping along the north and east sides of the building which will make it a more aesthetically pleasing site. Staff has reviewed the requests and recommend approval.

Acting Chairman Tucek asked for questions from the audience and there were none.

Draft

Acting Chairman Tucek asked for questions from the Commission.

Commissioners Morris and Pelella had no questions.

Commissioner Meneghini asked if they will be able to comply with the eight conditions.

Mr. Doyle stated yes we reviewed them all and we have no problem complying.

Commissioner Battisto asked about the current overflow of cars.

Mr. Doyle stated on average they are short now by about ten spaces. On the new building they will be adding 10 more stalls which is ten more spaces with 30 extra and I think that is going to come out almost perfect.

Acting Chairman Tucek stated it almost looks as if there is landscaping between the bike path and Gary Avenue. Is the petitioner responsible for that landscaping. But they are not there now though so the petitioner is not responsible for it.

Mr. Farace replied correct.

Commissioner Meneghini redirected and apologized for asking a question and not calling Mr. Doyle back up to the podium in order to hear his response.

Commissioner Petella moved and Commissioner Meneghini seconded the motion with no further discussion.

The results of the roll call vote were:

Ayes: 5 Commissioners Battisto, Meneghini, Morris, Petella, and Acting Chairman Tucek

Nays: 0

Abstain: 0

Absent: 2 Commissioner Christopher and Chairman Parisi

The motion passed by unanimous vote.

This case will go before the Village Board on Monday, August 7, 2023, at 6:00 PM for review.

**NEW BUSINESS:**

**PRESENTATION:**

**OLD BUSINESS:**

**OTHER BUSINESS:**

Mr. Farace stated the Commission can vote on canceling the August 14, 2023, meeting due to the lack of agenda items.

Commissioner Battisto moved and Commissioner Morris seconded the motion with no further discussion.

The results of the roll call vote were:

Ayes: 5 Commissioners Battisto, Meneghini, Morris, Petella, and Acting Chairman Tucek

Nays: 0

Abstain: 0

Absent: 2 Commissioner Christopher and Chairman Parisi

The motion passed by unanimous vote.

Commission Morris asked Mr. Farace if the project at the corner of Fair Oaks and Lies Road stopped. I heard a rumor that it had fallen through because the farmer has planted his crop and I think it is soybean. But I heard that it had stopped.

Mr. Farace stated no and they should be resubmitting very soon.

Then there was a brief discussion regarding approval of minutes.

Acting Chairman Tucek stated between the bar on North Avenue, which will be the cannabis dispensary, and the church, there is a new piece of construction. He then asked if that was Carol Stream.

Mr. Farace stated yes. You would have reviewed it last year. It is Dynamic Investments which is a truck repair facility.

Acting Chairman Tucek then asked about the corner of North Avenue and Morton because it's been cleared out. They are going to be constructing a new building in there aren't they.

Mr. Farace stated the corner of North Avenue and Morton is unincorporated for now.

Commissioner Morris stated but that's not ours. That is West Chicago unincorporated.

Mr. Farace stated for now it is unincorporated and you might see a proposal coming before the Commission.

Commissioner Morris asked if it is for annexation.

Mr. Farace stated right.

Commissioner Morris asked if there was a proposal on the table right now to build like a 8,500 square foot building and house 90 vehicles in there. He said that was in the paper.

Mr. Farace stated that was from the county. Yes, a similar proposal.

#### **PUBLIC HEARING:**

Acting Chairman Tucek asked for a motion to close the Public Hearing. Commissioner Battisto moved and Commissioner Morris seconded the motion.

The results of the roll call vote were:



Ayes: 5 Commissioners Battisto, Meneghini, Morris, Petella and Acting Chairman Tucek

Nays: 0

Abstain: 0

Absent: 2 Commissioner Christopher and Chairman Parisi

The motion passed by unanimous vote.

**ADJOURNMENT:**

At 6:18 p.m. Commissioner Battisto moved and Commissioner Morris seconded the motion to adjourn the meeting.

The results of the roll call vote were:

Ayes: 5 Commissioners Battisto, Meneghini, Morris, Petella, and Acting Chairman Tucek

Nays: 0

Abstain: 0

Absent: 2 Commissioner Christopher and Chairman Parisi

The motion passed by unanimous vote.

FOR THE COMBINED BOARD

Recorded and transcribed by,

\_\_\_\_\_  
Patty Battaglia

Planning and Permitting Assistant

Minutes approved by Plan Commission on this \_\_\_\_ day of \_\_\_\_\_, 20\_\_\_\_.

\_\_\_\_\_  
Acting Chairman

*Village of Carol Stream*  
**Interdepartmental Memo**

**TO:** Robert Mellor, Village Manager

**FROM:** Bravo Berisha, Assistant Planner *B.B.*

**THROUGH:** Donald T. Bastian, Community Development Director *DTB*

**DATE:** July 27, 2023

**RE:** **Agenda Item for the Village Board Meeting of August 7, 2023**  
**PC/ZBA Case 23-0030, Bartel's Auto Clinic – 160 S. Gary Avenue, Special Use Permit for an Auto Repair and Service Facility, Rear Yard Building Setback Variation, and Gary Avenue Corridor Review**

---

Tom Grotts, with E.P. Doyle & Son, on behalf of Patrick Bartel, owner of Bartel's Auto Clinic, requests approval of a Special Use Permit for an Auto Repair and Service facility, and a rear yard building setback Variation for the development of new Bartel's Auto Clinic facility at 160 S. Gary Avenue. The development will be an 8,481 square foot facility with 10 service bays. There will be 50 parking spaces to accommodate the growing needs of the business and to better serve customers. The parking spaces will exceed the maximum allowed, which is 20 percent beyond the minimum, but staff has reviewed the proposal and agrees that it is necessary for the development to function properly. Section 16-3-9 of the UDO states that the minimum setback for a rear yard is 20 feet in the Industrial District. Bartel's Auto Clinic proposes to reduce the rear yard property setback to 16 feet six inches. The Variation will maximize the working space inside the facility and is needed for the service bays to be built properly. Community Development staff and Engineering have reviewed the site plan and are supportive of the Variation. Architecturally, the new Bartel's facility will mimic the existing one in regard to design and with the proposed foundation and perimeter landscaping, staff believes the new facility will complement the existing facility and will provide another attractive site along the Gary Avenue corridor.

The staff report presenting the request, with supporting documentation, was transmitted to the Village Board with the PC/ZBA packet on July 21, 2023. At its meeting on July 24, 2023, by a vote of 5-0, the PC/ZBA recommended approval of the Special Use Permit, Zoning Variation, and Gary Avenue Corridor Review, subject to the conditions in the July 24, 2023 staff report.

If the Village Board concurs with the PC/ZBA recommendation, they should approve the Special Use Permit, and the Variation for Bartel's Auto Clinic, subject to the conditions contained within the Ordinance, and adopt the necessary Ordinance. Review and approval of Gary Avenue Corridor Review is not required.

ec: Tom Grotts, E.P. Doyle & Son

**Village of Carol Stream  
INTERDEPARTMENTAL MEMO**

**TO:** Mayor & Trustees  
**FROM:** Robert Mellor, Village Manager  
**DATE:** August 7, 2023  
**RE:** **Proposed Amendment to § 13-2-37 of the Village Code - Sewer Line Maintenance/Replacement**

At the July 17, 2023 regular Village Board meeting the Village Board directed staff to develop a Code amendment to address sanitary sewer service line repairs that occur under the roadway in the Village public right of way. This amendment was drafted to provide some relief to property owners who experience breaks in their private sanitary sewer service lines that occur under the Village roadway in consideration of some public benefit that otherwise would not occur if the repair were not made.

The grant would reimburse residents 50% of repair or replacement costs of their service lines falling under the Village roadway up to \$10,000 under conditions specified in the proposed Code amendment (attached) and later in a grant application.

Several points to consider:

- The program would only be available prospectively (not for prior service line repairs) and subject to a determination that the roadway surface could be compromised if the repair was not made.
- The property owner would be responsible for televising and recording the exact location of the service line issue to enable Village staff to determine whether the flow blockage is a maintenance or a repair issue and whether it is under the Village roadway or on private property.
- The Code, as amended would provide relief to all property owners experiencing service line breaks under the roadway (the current Code language also applies to all property owners).
- The maximum proposed grant amount is \$10,000.
- A sewer rate adjustment may be required depending on the level of participation in and amount of grant disbursements for this new program.

Residents who need to repair their service lines under the Village roadway would need to obtain a permit and secure quotes from a licensed plumber or sewer contractor before performing any work. The Village will assemble a list of qualified, licensed contractors for property owner consideration but not endorsement by the Village.

The property owner will be responsible for securing the permit and contracting the work, who would then submit a copy of the paid contractor invoice to the Village for reimbursement of 50% of the cost up to the maximum reimbursement of \$10,000. The proposed amendment (addition of section (F)) is attached to this memo.

### **§ 13-2-37 SEWER LINE MAINTENANCE/ REPLACEMENT.**

(A) The property owner is responsible for the maintenance and repair of the private sewer line from their structure to the main sewer or public sewer including the connection into the main/public sewer.

(B) In the event the property owner finds it necessary to excavate the private sewer line for maintenance or replacement, such excavation shall be the property owner's responsibility.

(C) In those instances when property owners have had to excavate and as a result the sidewalk, curb and street have been dug out or damaged, the property owner will be responsible for the restoration of the street (surface and sub-surface) curb and sidewalk.

(D) In those instances where division (C) of this section is involved, it is recommended tunneling under the curb and sidewalk whenever practical. Sidewalk and curb must be cut when removal is required.

(E) All work, as it is related to the replacement and/or repair of the private sewer line, shall be in conformance with the village standard construction specifications and will be inspected by a duly authorized agent of the village during the repair and replacement.

(F) The Village will participate in the repair or replacement of a private sanitary sewer service line located under the paved roadway within the Village's right-of-way subject to the following:

1. The sanitary sewer service line has been televised by the property owner and based on the evidence provided to the Village, to include video and evidence of location of the potential issue, the Village Engineer or Public Works Director have determined the sewer service line under the paved roadway presents the potential to damage the Village's paved roadway or the Village's sewer main if uncorrected; and
2. The only method of repair or replacement of the sanitary sewer service line requires excavation of the Village's paved roadway.
3. The Village will reimburse the property owner fifty-percent (50%) of the costs toward the repair or replacement of the private sanitary sewer line under the Village paved roadway and pavement repair in an amount not to exceed \$10,000. The applicant will be responsible for all additional costs associated with the sanitary sewer service line repair or replacement in excess of these amounts.
4. The applicant will indemnify, hold and release the Village from any and all liability arising from the repair of the sanitary sewer service line by the Village.
5. Repair or replacement of any private sanitary sewer line outside of a Village paved roadway will be not be eligible for reimbursement and shall remain the responsibility of the homeowner pursuant to subsections (A) through (E) of this section.
6. In all cases, maintenance of the entire private sanitary sewer service line shall remain the responsibility of the property owner, including but is not limited to flushing to clear blockages and root cutting in the property owner's service line.



Carol Stream Police Department  
 Memorandum

**TO:** Bob Mellor, Village Manager  
**FROM:** Bill Holmer, Chief of Police *WH*  
**DATE:** July 31, 2023  
**RE: REQUEST TO PURCHASE – VEHICLES**

**BACKGROUND**

Together with the Public Works and Finance Departments, we maintain a replacement schedule for vehicles within the Police Department. Over the past 2-3 years, we have experienced order cancelations and delays due to supply chain problems. We have had to be creative in finding and purchasing police cars. While we have seen some improvement, delays remain and the car market continues to be uncertain. Due to this uncertainty among manufacturers, we ordered cars from both Dodge and Ford last year with the understanding that we did not have to accept them if/when they arrived. We over-ordered because we were uncertain whether the orders would actually be fulfilled by the manufacturers.

This year's replacement schedule plans for the following four cars to be replaced:

Year	Make/Model	Current Mileage
2017 (#676)	Dodge Charger	103,000
2013 (#632)	Jeep Cherokee (unmarked)	114,000
2014 (#641)	Dodge Ram Pickup	90,000
2014 (#645)	Dodge Durango (unmarked)	84,000

**SUBJECT**

We recently learned that both Dodge and Ford have produced the cars from our orders last year, which means that we have nine cars available to us. Ford has also reported that they are reducing their production quantities for next year.

I recommend that we purchase six cars of the nine that are available. In addition to the replacements planned in the budget, this will allow us to replace two additional patrol cars that are a bit older, but have lower miles on them. These two cars will be reassigned as training cars, and will replace cars that are much older and have over 100,000 miles on them. This will finally put us in a position of turning a corner to put the overall fleet on more solid ground. While these two additional cars were not part of the FY 24 replacement plan, they are older

cars for which we had deferred replacement; they also experience intermittent problems (part of the reason that their miles are lower). I have reviewed this plan with the Finance Director and there are funds available in the vehicle replacement fund to support this purchase.

Last week, the Village Board provided preliminary approval for the purchase of the six cars so that we could release any that we did not want; and, take possession of the ones we do want.

### **RECOMMENDATION**

I recommend that we waive competitive bidding as authorized in section 5-8-14 of the Village Code, and purchase one (1) Ford Police Utility from Currie Motors for a total cost of \$43,277; and, five (5) Dodge Durangos from Thomas Dodge in Indiana for a total cost of \$205,787. Currie Motors holds the State of Illinois contract for the Ford Utilities; and, Thomas Dodge was able to fulfill the order for cars at a lower cost than the state contract.

The Village Board is asked to provide retroactive approval for this purchase.

If you have any questions, please contact me.

*Village of Carol Stream*  
Interdepartmental Memo

**TO:** Village Board  
**VIA:** Robert Mellor, Village Manager  
**FROM:** Joe Carey, Assistant Village Manager  
**DATE:** July 31, 2023  
**RE:** **Recommendation to Award to Chicago Sign Company for the Purchase of Replacement Electronic Message Sign (500 Gary Avenue)**

The adopted FY24 Budget included funds for the replacement of the electronic message board along 500 Gary Avenue in front of the Gregory J. Bielawski Municipal Facility. The current sign, installed by Chicago Signs in 2006 for \$45,698, is past its useful life with replacement parts no longer available.

Village staff solicited quotes from three companies and received the following pricing:

1. Chicago Sign Company - \$63,295
2. Allegra - \$69,195
3. Parvin Clauss - \$79,864

Chicago Signs has previously installed signage for the Carol Stream Library and Park District and provided the lowest pricing options with Option C being the same dimensions as the existing sign panels. Due to the unique characteristics of the purchasing of an electronic sign of this type and familiarity with Chicago Signs, a waiver of competitive bidding pursuant to Section 5-8-14 (M) of the Municipal Code is being requested. Staff recommends entering into a purchasing contract with Chicago Sign Company in the amount of \$63,295. Adequate funds are available for this purchase.

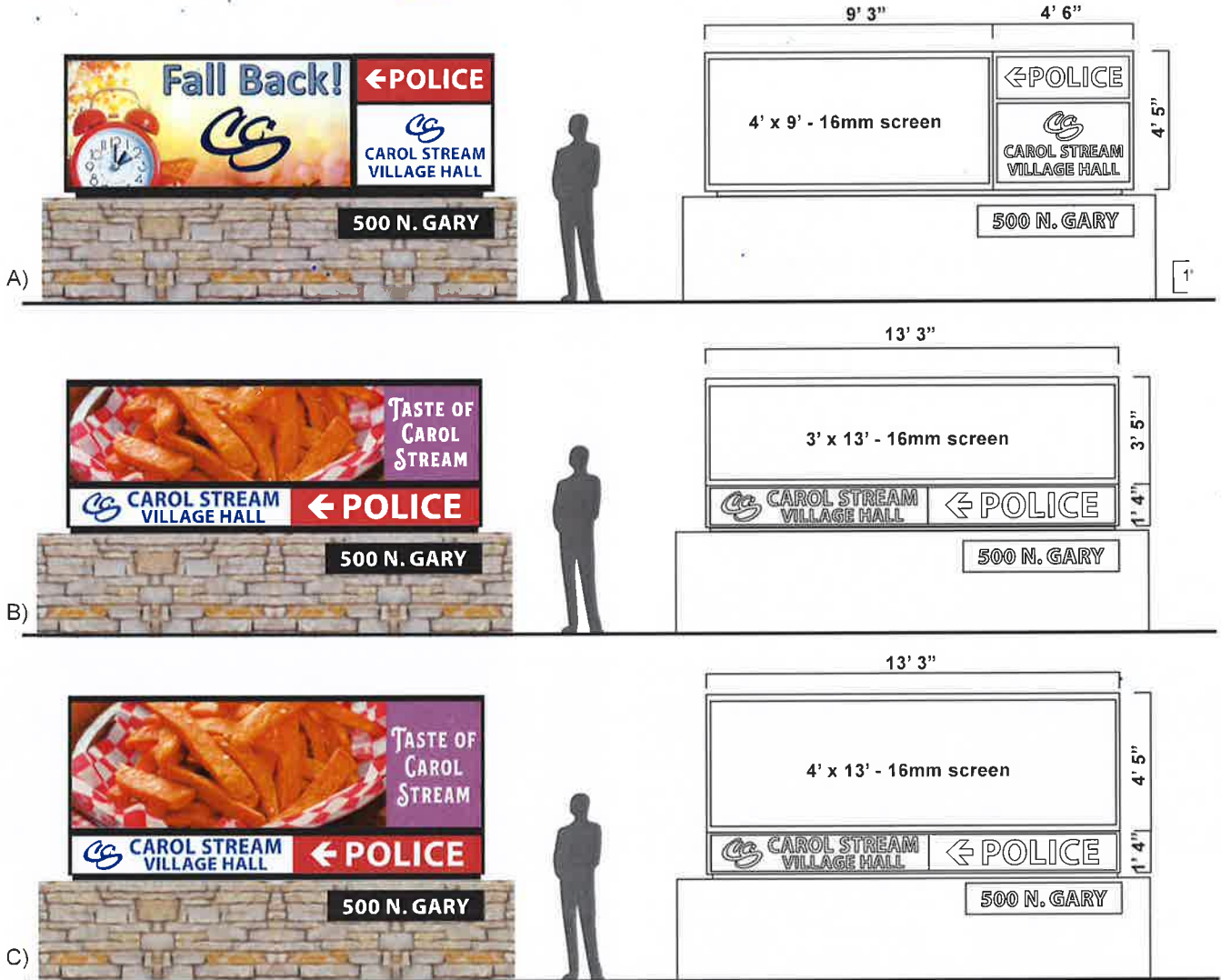

Proposal: 1) Sign A) Watchfire 4' x 9' EMC: \$32,985.00 Additional sign cabinet 53" x 54" , illuminated address sign removal of existing sign and installation of new signs: \$14,680.00 Total: \$47,665.00

Proposal: 2) Sign B) Watchfire 3' x 13' EMC: \$35,685.00 Additional sign cabinet 16" x 159" , illuminated address sign, removal of existing sign and installation of new signs: \$14,680.00 Total: \$50,365.00

Proposal: 3) Sign C) Watchfire 4' x 13' EMC: \$45,495.00 Additional sign cabinet 16" x 159" , illuminated address sign, removal of existing sign and installation of new signs: \$17,800.00 Total: \$63,295.00

Includes life of EMC sign data plan, 5 year parts warranty, 10 year parts availability. Permit expenses, landscaping, landscaping repair, electric service runs, would be additional or by others.

50% deposit with order, balance due upon completion.

Submitted for approval: John Doyle, President



*Village of Carol Stream*  
Interdepartmental Memo

TO: Robert Mellor, Village Manager

FROM: Brad C. Fink, Interim Director of Public Works 

DATE: August 7, 2023

RE: Recommendation for Purchase of a Public Works Skid Steer

The FY24 Budget includes \$85,000 in the Vehicle Replacement Fund for the purchase of a new skid steer to replace the existing unit #81. This existing 2005 skid steer has surpassed its useful service life and is primarily used by the Public Works Street Division for brush removal, snow removal, salt loading, brine making, concrete removal, dirt and mulch loading, as well as installing snow equipment on various large dump trucks.

Over the past six months Public Works demoed skid steers manufactured by CAT, CASE, John Deere, Bobcat, and New Holland. The Street, Water & Sewer, and Garage Divisions participated in the review of each unit including operating the equipment in actual field conditions. Staff selected the Bobcat model S76 skid steer that best suit our needs. The proposed unit will include a standard skid steer bucket, a concrete breaker, a set of hydraulic pallet forks, and a hydraulic snow blower attachment to assist in our snow removal efforts.

Staff has found the Bobcat S76 skid steer available under a joint-bid resource via Sourcewell (contract #040319-CEC) for \$88,915.00. The dealer has also offered a trade-in on the Village's existing skid steer in the amount of \$15,250.00. Because this unit is an older model (2005) and our Fleet Supervisor's assessment of its current condition and value, this offer appears to represent a very attractive trade-in price. The total purchase price with trade-in is \$73,665.00.

If approved, staff will complete up-fitting with a bucket scale that will allow us to more accurately track salt usage, channel 4 radio, necessary safety lighting, and decals at an additional estimated cost of \$10,000. The total cost of the new skid steer with trade-in and upfitting will be approximately \$83,665.00.

It is recommended that the Village Board approve a Motion to purchase a 2023 Bobcat S76 skid steer from Atlas Bobcat under Sourcewell Contract #040319-CEC in the amount of \$88,915.00, and accept \$15,250.00 for trade-in of the existing skid steer, pursuant to the provisions of Section 5-8-3(B) and subsection 5-8-14(L) of the Carol Stream Code of Ordinances.

Attachments



## Product Quotation

Quotation Number: 41515D042085

Date: 2023-08-01 11:24:43

Ship to	Bobcat Dealer	Bill To
Village of Carol Stream Attn: Andrew Olsen 124 Gerzevske Ln Carol Stream, IL 60188 Phone: (630) 871-6260 Email: aolsen@carolstream.org	Atlas Bobcat, West Chicago, IL 600 W. ROOSEVELT ROAD WEST CHICAGO IL 60185 Phone: (630) 293-0606 Fax: (630) 293-5788  Contact: Todd Swartz Phone: 847-678-3633 Fax: 847-678-3587 Cellular: 847-529-1191 E Mail: tswartz@atlasbobcat.com	Village of Carol Stream Attn: Andrew Olsen 124 Gerzevske Ln Carol Stream, IL 60188 Phone: (630) 871-6260

Description	Part No	Qty	Price Ea.	Total	
<b>S76 T4 Bobcat Skid Steer Loader</b>	M0369	1	\$50,927.00	\$50,927.00	
<i>B22167 S/N B4CD21718</i>					
<i>2023 with Aprox 27 Hours</i>					
Warranty Plans	60 Month Protection Plus (2000 Hours)	9986172	1	\$2,000.00	\$2,000.00
Factory Installed	P95 Features On Demand Package	M0369-P06-P95	1	\$4,637.00	\$4,637.00
	C68 Comfort Package	M0369-P07-C68	1	\$7,772.00	\$7,772.00
	Selectable Joystick Controls	M0369-R01-C04	1	\$862.00	\$862.00
	S76 2-Speed Travel FOD Enable	9986483	1	\$0.00	\$0.00
	S76 Automatic Ride Control FOD Enable	9986485	1	\$416.00	\$416.00
	S76 Dual Direction Bucket Positioning FOD Enable	9986484	1	\$0.00	\$0.00
	S76 High Flow Hydraulics FOD Enable	9986482	1	\$1,261.00	\$1,261.00
	S76 Reversing Fan FOD Enable	9986486	1	\$346.00	\$346.00
Dealer Installed	Strobe Light Kit, Amber	7375339	1	\$442.00	\$442.00
Attachments	74" Heavy Duty Bucket	7272680	1	\$1,977.00	\$1,977.00
	--- Bolt-On Cutting Edge, 74"	6718007	1	\$383.00	\$383.00
	48" Hydraulic Pallet Fork	6905425	1	\$3,694.00	\$3,694.00
	NB160 Nitrogen Breaker with Nail Point	7234536	1	\$7,752.00	\$7,752.00
	--- Loader Mounting Frame	7113737	1	\$1,112.00	\$1,112.00
	--- Hose Kit - Breakers - Ldr	7114764	1	\$426.00	\$426.00
	Snow Blower 32X74	M7045	1	\$6,919.00	\$6,919.00
	--- MOTOR PACKAGE 160CC (26-31 gpm)	M7045-R01-C04	1	\$989.00	\$989.00

Total of Items Quoted		<b>\$91,915.00</b>
Trade-in	2005 Deere 325 with bucket, breaker, forks	<b>(\$15,250.00)</b>
Discount	\$3000 S64/S66/S76/E88 Municipal Rebate	<b>(\$3,000.00)</b>
Quote Total - US dollars		<b>\$73,665.00</b>

**Notes:**

Discount per the Sourcewell Contract #040319-CEC. Effective thru 08-31-2023

All prices subject to change without prior notice or obligation. This price quote supersedes all preceding price quotes.

Customer Acceptance:

Purchase Order: \_\_\_\_\_

Authorized Signature:

Print: \_\_\_\_\_ Sign: \_\_\_\_\_ Date: \_\_\_\_\_



**Bobcat**®

## R-SERIES LOADER

# S76

Operating Weight	3908 kg
Engine Power	74 HP (55.2kW)
Rated Operating Capacity (50% of tipping load)	1338 kg



***One Tough Animal***

# S76 - SPECIFICATIONS

Loader Series	R-Series
Rated Operating Capacity (50% of tipping load)	1338 kg (2950 lb.)
Tipping Load (ISO 14397-2)	2676 kg (5900 lb.)
Height to Bucket Hinge Pin	3259 mm (128.3 in.)
Lift Arm Path	Vertical
<b>Size and Speed</b>	
Operating Weight	3908 kg (8615 lb.)
Width with Bucket	1880 mm (74 in.)
Height with Cab	2078 mm (81.8 in.)
Travel Speed – Low Range	10.9 km/hr. (6.8 mph)
Travel Speed – High Range (optional 2-Speed travel)	18.9 km/hr (11.8 mph)
<b>Engine</b>	
Horsepower	74 HP (55.2kW)
Type	Turbo Diesel
Fuel Tank Capacity	120.0 L (31.7 gal)
Horsepower Management	Included with SJC Option
<b>Control Options</b>	
Bobcat Standard (foot pedals/steering levers)	Std
<b>Hydraulic System</b>	
Hydraulic System Pressure	23.8-24.5 MPa (3450-3550 psi)
Hydraulic Standard Flow	88.1 L/min. (23.3 gpm)
Hydraulic High Flow (optional)	114.7 L/min. (30.3 gpm)
Pressure Release Hydraulic Quick Couplers	Std
Speed Management	Included with SJC Option
<b>Standard Features</b>	
ROPS/FOPS Approved Cab Structure	Back-Up Alarm and Horn
Bobcat Interlock Control System (BICS™)	Bob-Tach Mounting System
Standard Display (includes keyless start)	Fingertip Auxiliary Hydraulics Control
LED Front and Rear Work Lights	Pressure Release Hydraulic Quick Couplers
Mechanical Suspension Seat	
<b>Options</b>	
Radio Remote Control (SJC required)	Reversing Fan
Heated Cloth Air-Ride Seat	Automatic Ride Control
Cab with Heat	Side Lighting Kit
Cab with Heat and Air Conditioning	Sound Reduction
Dual Direction Bucket Positioning	Bob-Dock System
Radio	Power Bob-Tach System
2-Speed Travel	Attachment Control Kit



**Bobcat is a Doosan company.**  
Doosan is a global leader in construction equipment, power and water solutions, engines, and engineering proudly serving customers and communities for more than a century. Bobcat and the Bobcat logo are registered trademarks of Bobcat Company in the United States and various other countries.  
©2020 Bobcat Company. All rights reserved.

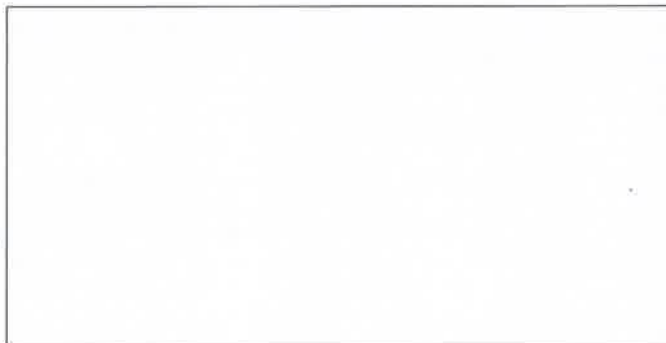

## Dimensions

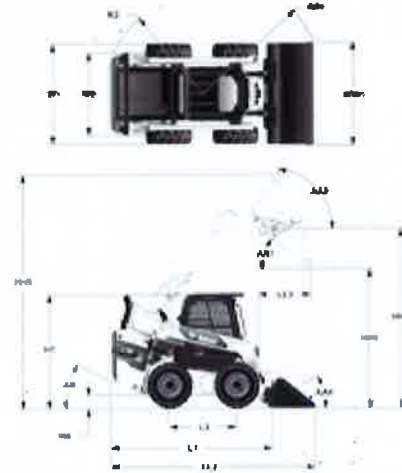

Rear of Machine Clearance Radius	R2	1788 mm
Carry Position Machine Clearance Radius	RR1	2228 mm
Overall Width	W1	1829 mm
Tread(Track Gauge)	W3(W2)	1504 mm
Bucket Width	WW1	1880 mm
Overall Operating Height	HH5	4252 mm
Overall Height	H1	2079 mm
Angle of Departure	A4	27 degrees
Ground Clearance	H4	223 mm
Wheelbase	L3	1227 mm
Length without Attachment	L1	2893 mm
Overall Length	LL2	3737 mm
Maximum Rollback - Fully Raised	AA2	94 degrees
Dump Angle	AA1	37 degrees
Reach - Fully Raised	LL3	950 mm
Dump Height	HH3	2526 mm
Maximum Rollback - Carry Position	AA4	31 degrees
Height to Hinge Pin	HH4	3259 mm

## Attachments

Angle Broom	Rock Bucket
Auger	Scarifier
Blades — Box, Dozer, Snow, Snow V-Blade	Scraper
Brush Saw	Seeder
Brushcat™ Rotary Cutter	Silt Fence Installer
Buckets	Snow Pusher
Combination Bucket	Snowblower
Concrete Mixer	Sod Layer
Concrete Pump	Soil Conditioner
Digger	Spreader
Drop Hammer	Stabilizer, Rear
Dumping Hopper	Stump Grinder
Flail Cutter	Sweeper
Grader	Tiller
Grapples — Farm / Utility, Industrial, Root	Tilt-Tatch™
Landscape Rake	Tree Spade
Laser Equipment	Trench Compactor
Mower	Trencher
Packer Wheel	Utility Fork
Pallet Fork	Utility Frame
Planer	Vibratory Roller
	Water Kit
	X-Change™ Frame

Certain specification(s) are based on engineering calculations and are not actual measurements. Specification(s) are provided for comparison purposes only and are subject to change without notice. Specification(s) for your individual Bobcat equipment will vary based on normal variations in design, manufacturing, operating conditions, and other factors. Pictures of Bobcat units may show other than standard equipment.



# Bobcat®

Doosan Bobcat Korea Co., Ltd.

www.bobcat.com

*Village of Carol Stream*  
Interdepartmental Memo

TO: Robert Mellor, Village Manager

FROM: Brad C. Fink, Interim Director of Public Works 

DATE: August 7, 2023

RE: Recommendation to Repair the Roof at the Public Works Center North Garage

In April 2023 the roofing shingles on the south half of the Public Works Center (PWC) North Garage sustained significant damage from a storm that passed through Carol Stream. The extent of the damage to the shingles requires a complete replacement. Staff solicited quotes to remove the existing shingles down to the sheathing and install a new roof. The following roofing companies submitted proposals:

STA Enterprises, Inc.	\$36,222.00
Charles Copley Roofing, Inc.	\$41,410.00
Olsson Roofing Company, Inc.	\$62,815.00

While proposals were being requested, staff worked with Intergovernmental Risk Management Agency (IRMA) to confirm the roof replacement would be covered by insurance. IRMA reviewed the proposal from Charles Copley Roofing, Inc. and approved the replacement value of \$40,112.23. The Village has received \$37,563.04 and IRMA will submit the remaining balance of \$2,549.28 once the work is completed.

Staff has worked with Charles Copley Roofing, Inc. in the past with excellent results. Most recently in 2020, Charles Copley Roofing, Inc. repaired the roof on the Well House at the PWC.

Staff recommends that the Mayor and Board approve a motion waiving competitive bidding and authorizing the proposal from Charles Copley Roofing, Inc. for the replacement of the south half of the PWC North Garage in the amount of \$41,410.00.

Attachments



**L.J. SHAW**

EST. & 1932

**COMPANY**

MAIN OFFICE  
1100 S. MAIN STREET  
LOMBARD, IL 60148-3971  
P: (630) 932-0707  
F: (630) 932-1392  
MAIL@LJSHAW.COM

BRANCH OFFICE  
200 S. EXECUTIVE DRIVE, SUITE 101  
BROOKFIELD, WI 53005  
P: 262-789-3167

NINO A. BERARDI, RPA  
PAUL A. VANDERHEYDEN, RPA  
MICHAEL R. SCHWARTZ, AIC, AINS, RPA

KEVIN M. YOUNG  
T. R. COPPOCK, AIC  
CARLOS A. TOBIAS  
ANTHONY W. VANDERHEYDEN, AIC  
TIMOTHY E. COPPOCK  
WILLIAM J. JENSEN, AIC  
WILLIAM L. HALL, AIC, OFA 102  
RANDALL A. FERRARI  
STEPHEN S. HASTINGS (1939-2021)

April 27, 2023

IRMA/Intergovernmental Risk Management Agency  
999 Oakmont Plaza Drive, Suite 310  
Westmont, IL 60559

Attention: Colleen Rhodes

Re: Claim No. 18357101  
Village of Carol Stream  
124 Gerzevske Lane  
Carol Stream, IL 60188  
D/L: March 31, 2023 - wind  
Our File No. 72217K

**First and Final Report**

**SOURCE AND DATE OF ASSIGNMENT**

This assignment was received from your company and the member, Brad Fink was reached on April 19, 2023. Our inspection was made with the member on April 24, 2023.

**ENCLOSURES**

1. Adjuster's detailed roof repair estimate
2. Adjuster's photographs from inspection (21)
3. Adjuster's fee bill

**ESTIMATE**

**Building -Public Works North Garage**

Replacement cost loss	\$40,112.32
Less depreciation	<u>(2,549.28)</u>
Actual cash value loss	<u>\$37,563.04</u>

**RISK**

The risk where the damages occurred is a one-story joisted masonry public works north garage. The risk is located at 124 Gerzevske Lane, Carol Stream, IL 60188. The roof consists of wood shed construction with an asphalt laminate roof covering. Photographs from our inspection are attached.



### OWNERSHIP/LEGAL INTEREST

The named member shown on your policy declaration pages is the Village of Carol Stream. The contact person we have been dealing with has been Brad Fink. His contact number is 630-390-6763. The mailing address for the member is the loss location.

### CAUSE OF LOSS

The member submitted a claim for wind damage to a south facing slope of the public works north garage roof. According to the member heavy winds on March 31, 2023, damaged the shingles along the south slope of the public works garage. No interior water leaking was reported. Photographs from our inspection are attached.

### SUBROGATION

Based on our findings, please advise us if you wish us to comment further regarding this aspect of the claim. We leave the subrogation venture to your company's discretion.

### SALVAGE

Not involved.

### ADJUSTMENT

#### What has been done

Our inspection revealed damage to the south facing slope only. No evidence of wind or hail damages were revealed to the north facing slope.

After our inspection, we prepared a detailed estimate for the replacement of the south facing slope. Please note the member's contractor, Charles Copley Roofing, also recommends replacing the south slope due to wind damages as well.

The estimate received from the member's contractor was in the amount of \$41,410.00. We completed a price comparison estimate and calculated a replacement cost loss of \$40,112.32. We do not know if the difference has to do with the contractor charging the member material sales tax since it was not broken down in lump sum format. Depreciation was applied to materials only in the amount of \$2,549.28 thereby arriving at an actual cash value loss of \$37,563.04. If you are agreed to our calculations, we would recommend issuing payment to the member in this amount.

### CLOSING COMMENTS

With our assessment of this claim now completed with issuance of this report we are closing our file. If you need additional assistance from our office, please contact us. Thank you for allowing us to serve your company.

Very truly yours,

L. J. SHAW AND COMPANY

---

T. R. Coppock, General Adjuster - AIC

TRC:sf

# CHARLES COPLEY ROOFING, INC.



LICENSE 104.001399  
 office@copleyroofing.com  
 www.copleyroofing.com

"Crystal Lake's Oldest and Finest Since 1968"  
 835 E. Terra Cotta Avenue · Crystal Lake, IL 60014  
 815-459-5493

April 18, 2023

- Proposal - Emailed 4/14/23

PROPOSAL FOR:	CONTACT INFO:	JOB INFO (IF DIFFERENT)
Village of Carol Stream Public Works	Phone: 630-391-8717 Cell: hschmalen@carolstream.org E-mail:	North Garage Roof 124 Gezevske Av Carol Stream, IL

Thank you for the opportunity to provide this proposal. Please read all pages (both sides) carefully. **If you choose to accept, please initial Accept or Decline for each segment of the proposal, sign the proposal in the acceptance block at the end & initial on the bottom of the Important Notes page.** Return one signed copy (all pages) to Copley Roofing. You may also need to make color selection(s). Color samples of materials are available at our office.

**PROPOSED ROOFING: (Front Side Only)**

1. Tear off 1 layer of existing roofing materials down to bare roof sheathing. Re-nail any loose or improperly nailed sheathing. Replace any rotted or damaged sheathing on a time & material basis – call for current pricing.
2. Install Grace Select Ice & Water Shield6' up from the eaves.
3. Install approx 80 lin ft of Royal Brown aluminum drip edge to gables.
4. Cover remaining roof area with Grip-Rite synthetic underlayment or equivalent.
5. Install approx (68) squares of GAF Timberline HDZ Limited Lifetime architectural shingles. Nail each shingle with (6) 1 ¼" galvanized roofing nails, twelve nails per shingle. Also choice of Owens Corning.
6. Rework existing baby tin flashings laced into the courses of shingles at pitched wall junctions.
7. Replace (1) 4" lead soil stack flashing.
8. Replace approx 172 lin ft of ridge vent with Air Vent - Shingle Vent II continuous ridge vent & ridge cap shingles over vent.
9. Clean up & remove all job related debris from gutters & surrounding area.

\* Price is based on in-stock colors. \*

**JOB COST: \$41,410.00**  **Accept**  **Decline**

All work shall be performed by skilled tradesmen fully covered by Liability Insurance & Workmen's Compensation Insurance. A Certificate of Insurance for your job is available from our insurance carrier on request. Property owner shall carry appropriate property owners insurance.

The respective manufacturers warrant their materials to be and to perform as specified. **Charles Copley Roofing warrants installation & workmanship for ten years.**

**\*No warranty on repairs.** Installation shall comply with standard industry practices and manufacturers' specifications. Charles Copley Roofing is not liable to repair or replace materials damaged by accident, vandalism, foreign object, shifts in the building structure, excessive forces of nature, or acts of God.

Any deviation from the signed proposal that results in additional cost (except wood replacement or necessary repairs) will be performed only with the property owner's authorization and will become an extra charge above the original contract price. Timely performance may be affected by weather, labor disputes, material shortages, accidents, or delays beyond our control. In breach of contract, the property owner is responsible for all legal fees.

**PERMITS: Property owner is responsible for obtaining any permits required for the contracted work or a \$50.00 processing fee will be charged plus any permit fees.**

**TERMS: PAYMENT IN FULL IS DUE ON COMPLETION.** A 2% per month late charge will be added to past-due accounts. We accept cash, check, bank draft, title company check, **credit/debit card (up to \$3,000.00)**, or any combination thereof as direct payments. We offer installment payment plans through a third party lender. <sup>††</sup> Service Fees may apply. Additional financing terms available. **Additional Costs are not included in financing quotes.** By using a check for payment, you agree to the following terms: In the event your check is dishonored or returned for any reason, you authorize us to electronically (or by paper draft) re-present the check to your bank account for collection of the amount, plus any applicable fees as permitted by state law.

**Prices are subject to change after 30 days due to material cost.**

**PROPOSAL SUBMITTED BY:**

Mike Lesko

**ACCEPTANCE:** By signing this document, I attest that I am the property owner/authorized representative and I authorize the work to be performed in accordance with the prices, terms and conditions of this proposal.

X \_\_\_\_\_

**ACCEPTANCE SIGNATURE: DATE**

**PRINTED NAME:** \_\_\_\_\_



*Village of Carol Stream*  
Interdepartmental Memo

TO: Robert Mellor, Village Manager

FROM: Brad C. Fink, Interim Director of Public Works 

DATE: August 7, 2023

RE: Recommendation for Purchase of Mobile Lift Columns

The FY24 budget includes \$70,000 for the purchase of four (4) mobile lift columns for use in the fleet maintenance garage. These columns are intended to supplement the existing mobile lift column that were purchased in 2017. The additional mobile lift columns will offer immediate benefits for safely lifting any vehicles in the Village fleet anywhere on the Public Works Center grounds.

The proposed Stertil-Koni mobile lift columns are offered by Safetylane Automotive Equipment through the Sourcewell joint-purchasing cooperative Contract #013020-SKI. Each unit will be programed to work with the existing four (4) mobile lift columns and has a 18,500 pound lifting capacity, which enables staff to lift the new combination sewer machine and our largest dump trucks (even fully-loaded with salt). The price to purchase four (4) additional mobile lift columns would be \$67,012.61.

It is recommended that the Village Board approve a Motion to purchase four (4) mobile lift columns from Safetylane Automotive Equipment under Sourcewell Contract #013020-SKI in the amount of \$67,012.61 pursuant to the provisions of Section 5-8-3(B) and subsection 5-8-14(L) of the Carol Stream Code of Ordinances.

Attachments



# PROPOSAL

Safetylane Automotive Equipment  
A Division of SLE Technologies, Inc.  
P.O. Box 83 | 212 N. Main Street  
317.326.5550  
Maxwell IN 46154

DATE 5/8/2023    EXPIRATION 5/8/2023    ESTIMATE # 8701  
ORDERED BY    P.O. #

**BILL TO**  
Andrew Olson  
SL - Village of Carol Stream  
Public Works  
124 Gerzevske Lane  
Carol Stream IL 60188 USA

**SHIP TO**  
Andrew Olson  
SL - Village of Carol Stream  
Public Works  
124 Gerzevske Lane  
Carol Stream IL 60188 USA

**Scope of Work**

ITEM	DESCRIPTION	QTY	RATE	AMOUNT
ST-1085-2RWA	Set of 4 - 74,000lbs capacity, 24 volts DC, control box on every column. Adj forks	1.00	64,312.61	64,312.61
Freight	Freight	1.00	2,000.00	2,000.00
Labor-Other	Re-program the Four existing lifts to match the new Lifts and give them a quick look over	1.00	700.00	700.00

**SUBTOTAL** 67,012.61

**67,012.61**

We impose a surcharge of 3.5% on the all transactions processed using a credit card. Please note this charge is for payment by credit/debit card only. You have the option to pay by check or cash without any additional fee.

Sourcewell Procurement # 013020 SKI

Approved By \_\_\_\_\_

Date of Acceptance \_\_\_\_\_

**steriti**<sup>®</sup> **KONI**

MOBILE COLUMN LIFT

# ST 1085 - ST 1100

Capacity 18,500 lbs.  
or 22,000 lbs.



 **ebright**  
SMART CONTROL SYSTEM



**STERTIL**  
SUPERIOR SOLUTIONS BY  
QUALITY PEOPLE

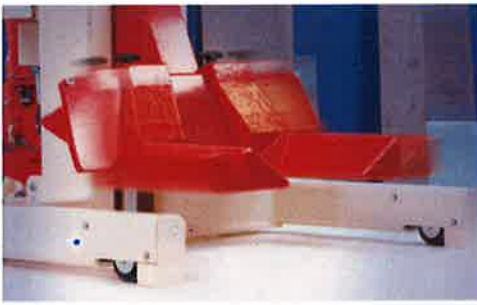

## Reliable hydraulic technology

- Extended column life and minimal maintenance thanks to low-friction design
- Stringent testing before leaving the factory
- Manual lowering in case of a power outage
- Maximum protection of the cylinder and seal against damage

## Adjustable pick-up forks

ST 1085 mobile column lifts have a fork length of 14", ideal for picking up a variety of vehicles, including vehicles with super single tires in a safe and secure manner. The fork length for the ST 1100 mobile column lift is 12". Both models can handle wheels with rim diameters from R12 to R22.5 with an adjustable fork that is easy to move manually and includes a mechanical lock.

## Retractable wheels

Both the wireless and the cabled mobile column lifts are available with retractable wheels. This unique Stertil-Koni design is the best available on the market. This prevents high point loading on the floor and reduces the floor surface pressure by a factor of 10. The system is fast, efficient, very stable and extremely reliable.

## Adjustable lowering speed

If you need to lower the vehicle more slowly for precision placement of under carriage components, this is easily done with a single touch.



## Power supply

The Stertil-Koni wireless mobile column lifts operate on 24 VDC and are easily recharged by means of a 110 VAC wall receptacle. The Stertil-Koni cabled mobile column lifts operate on three phase at 208/230, 460/480 and 575 VAC, as well as single phase at 220 VAC.

## Fast lifting and lowering

The ST 1085 and ST 1100 only take 94 seconds to reach its maximum lifting height of 73". This makes them one of the fastest mobile column lifts in the world.

# Well thought out in all aspects



32  
MAX

MAX 32 LINKED  
COLUMNS



ADJUSTABLE  
LOWERING SPEED



OVERLOAD  
PROTECTION



UNIQUE  
SYNCHRONIZATION  
SYSTEM

## Easy to move

Stertil-Koni mobile column lifts are indeed mobile, thanks to the synthetic roller wheels and hydraulic pallet jack mechanism with patented overload protection.

## Safe working space

As an extra safety feature, we have also designed ample working space between the column and the vehicle. This ensures that the vehicle will not come into contact with the column in the event of sagging vehicle suspension.

## Unique synchronization

The synchronization system is activated at a height difference of just 9/16". This ensures a safe and smooth lifting and lowering cycle, even in cases where the distribution of the vehicle weight is extremely uneven.

## Lifetime guarantee

The innovative synthetic runner wheels within the column come with a lifetime parts guarantee.



○ High resolution 7" touch screen

○ Intuitive controls



## ebright Features

- High resolution 7" touch screen
- Owner/User configurable system with user ID key
  - Individual user settings for setting language and units of measure
  - Protection against unauthorized use, thanks to personalized ID key
- Maintenance notifications
- Visual display of maximum programmable lifting height
- Warning and failure information
- Operation manual available on-screen
- Tracking of specific operations and information codes
- Intuitive controls with actual data about the lift:
  - Indication for Single, All or Pair operation mode
  - Information about how many columns are in the set (up to 32 columns)
  - Actual lifting height displayed
  - Lowering speed can be manually adjusted on the touch screen
  - Battery status information
  - Customizable ID-Key to prevent unauthorized operation
- Wireless Mesh network with continuous active channel search offering optimal connectivity

# Everything under control



Overview of ST 1085 – ST 1100 models	ebright wireless ST 1085-FWA ST 1100-FWA	ebright wireless ST 1085-RWA ST 1100-RWA	ebright cabled ST 1085-FSA ST 1100-FSA	ebright cabled ST 1085-RSA ST 1100-RSA
ebright Smart Control System with a control box on each individual mobile column	●	●	●	●
Touch screen with important information about the system e.g. lifting height, operation mode	●	●	●	●
Wireless Mesh network with continuous active channel search offering optimal connectivity	●	●		
These columns utilize a power outlet in the workshop and communicate with each other via interconnecting cables			●	●
Adjustable lowering speed for slow or normal lowering	●	●	●	●
Hydraulic pallet truck mechanism with patented overload protection	●	●	●	●
14"-long adjustable fork, suitable for super single tires	ST 1085	ST 1085	ST 1085	ST 1085
12"-long adjustable fork	ST 1100	ST 1100	ST 1100	ST 1100
Fixed synthetic wheels that reduce the floor surface pressure	●		●	
Retractable synthetic wheels integrated into the base frame, for 10x less floor pressure		●		●

## Technical specifications

- Lifting capacity: 18,500 lbs. or 22,000 lbs.  
 Lift system: hydraulic lifting system with microprocessor-controlled synchronization  
 Lifting height: maximum 73", automatic stop at the highest position  
 Lifting time: 94 seconds  
 Motor rating: 3 hp / 4 hp per column (Cabled/Wireless)  
 Weight: 1,350 lbs per column (Wireless)  
 Column lift height: 97"

## Highest safety requirements

- ANSI/ALI-ALCTV certified (USA), CSA certified (Canada), CE certified (Europe)
- Independent mechanical locking system engages at 5" above finished floor. Locking pawl engaged by gravity. The locking system is always active, even when the column is turned off
- Locking profile with locking increments of just 1-3/8"
- Synchronization between the mobile lifting columns starts at a height difference of 9/16"
- Automatic overload protection
- Low voltage control panel with emergency stop
- Each column is equipped with hold-to-run push buttons
- Each individual mobile lifting column is tested prior to leaving the factory
- Splash-proof electrical system (IP 65).

## Accessories & options

Stertil-Koni offers an extensive package of accessories & options tailored to fit your specific needs.

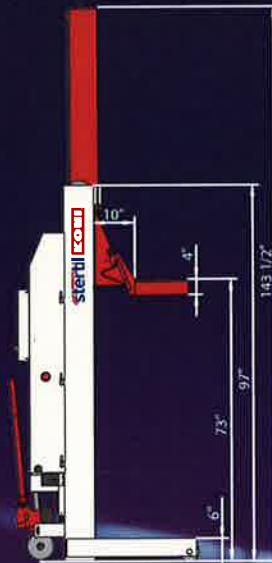

Fixed front wheels

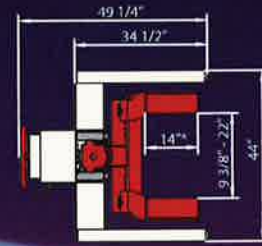

Adjustable forks

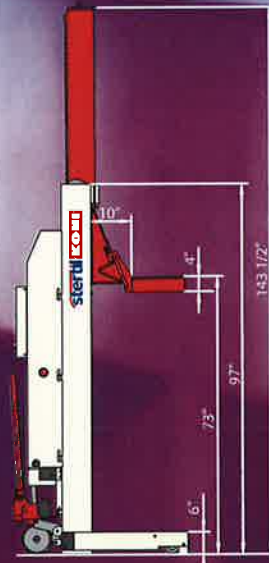

Retractable front wheels

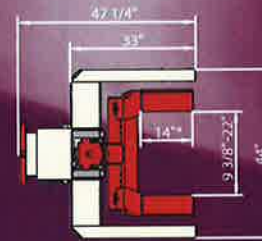

Adjustable forks

\* For the ST 1100: 12"

## More information?

For more information about the ST 1085, ST 1100, or any of Stertil-Koni's other top products, please do not hesitate to contact us. We will be pleased to assist you.



Stertil-Koni U.S.A. Inc.  
 200 Log Canoe Circle  
 Stevensville, Maryland 21666  
 Tel. 410-643-9001  
 Toll free 800-336-6637  
 Fax 410-643-8901  
 www.stertil-koni.com  
 lifts@stertil-koni.com

f StertilKoniUSA @StertilKoniUSA

A member of the Stertil Group



*Village Of Carol Stream*  
Interdepartmental Memo

**TO:** Robert Mellor, Village Manager  
**FROM:** Adam Frederick, Assistant Village Engineer   
**DATE:** August 2, 2023  
**RE:** **Award of Contract – 2023 Pavement Patching Contract**

On August 2<sup>nd</sup> at 10:00 a.m. Engineering Staff opened bids for the referenced project. The following bids were read aloud:

Schroeder Asphalt Services, Inc., Huntley, IL	\$51,920.00
JA Johnson Paving, Inc., Arlington Heights, IL	\$62,950.00
Chicagoland Paving Contractors, Inc., Lake Zurich, IL	\$65,000.00
Engineer's Estimate	\$73,747.44

The low bid received was under the Engineer's Estimate of \$73,747.44 by \$21,827.44.

A total of \$500,000 is budgeted between the Pavement Rejuvenator Project, the Restorative Sealer Project, Pavement Marking Project and the Patching Project. Between the four projects ample funds remain for the Pavement Patching Project.

Schroeder Asphalt Services completed this project successfully in the past. Staff therefore recommends award of the contract to Schroeder Asphalt Services, Inc. at the bid unit prices submitted.

Attachments:  
Bid Tabs  
2 Copies – Contract for Mayor and Clerk's Signature

cc: William N. Cleveland, Director of Engineering Services  
Jon Batek, Finance Director

2023 Pavement Patching Project (#8590623)  
 Owner: Carol Stream IL, Village of  
 Solicitor: Carol Stream IL, Village of  
 08/02/2023 10:00 AM CDT

Section Title	Line Item	Item Code	Item Description	UofM	Quantity	Schroeder Asphalt Services, Inc.		J.A. JOHNSON PAVING CO		Chicagoland Paving Contractors, Inc.	
						Unit Price	Extension	Unit Price	Extension	Unit Price	Extension
Base Bid							\$51,920.00		\$62,950.00		\$65,000.00
	1		1 Class D Patches, Type IV, 2"	SQ YD	1500	\$25.00	\$37,500.00	\$30.00	\$45,000.00	\$30.00	\$45,000.00
	2		2 Class D Patches, Type IV, 4"	SQ YD	210	\$52.00	\$10,920.00	\$60.00	\$12,600.00	\$60.00	\$12,600.00
	3		3 Traffic Control and Protection	LS	1	\$3,500.00	\$3,500.00	\$5,350.00	\$5,350.00	\$7,400.00	\$7,400.00
Base Bid Total:							\$51,920.00		\$62,950.00		\$65,000.00

*Village Of Carol Stream*  
Interdepartmental Memo

**TO:** Robert Mellor, Village Manager  
**FROM:** Adam Frederick, Assistant Village Engineer   
**DATE:** August 2, 2023  
**RE:** **Award of Contract - 2023 Crackfill Project**

On August 2<sup>nd</sup> at 11:00 a.m. Engineering Staff opened bids for the referenced project. The following bids were read aloud:

SKC Construction, Inc., West Dundee, IL	\$ 78,148.00
Denler Inc., Joliet, IL	\$ 79,800.00
Engineer's Estimate	\$ 100,000.00

The low bid received was under the budget and the Engineer's Estimate of \$100,000.00 by \$21,852.00. The budgeted amount for this project is \$100,000.00 through the MFT Fund.

SKC Construction has completed this project successfully for the Village several times in the past. Staff therefore recommends award of the contract to SKC Construction, Inc. at the bid unit prices submitted.

**Attachments:**

Bid Tab

2 Copies of Contract for Mayor and Clerk's Signature

cc: William N. Cleveland, Director of Engineering Services  
Jon Batek, Finance Director

2023 Crackfill Project (#8590627)  
 Owner: Carol Stream IL, Village of  
 Solicitor: Carol Stream IL, Village of  
 08/02/2023 11:00 AM CDT

Section Title	Line Item	Item Code	Item Description	UofM	Quantity	SKC Construction Inc.		Denler, Inc.	
						Unit Price	Extension	Unit Price	Extension
Base Bid							\$78,148.00		\$79,800.00
	1		1 Fiber Asphalt	LB	52000	\$1.49	\$77,428.00	\$0.20	\$10,400.00
	2		2 Fine Aggregate (FA-1)	TON	20	\$11.00	\$220.00	\$10.00	\$200.00
	3		3 Traffic Control and Protection	LS	1	\$500.00	\$500.00	\$69,200.00	\$69,200.00
Base Bid Total:							\$78,148.00		\$79,800.00

Village of Carol Stream

Interdepartmental Memo

TO: Robert Mellor, Village Manager  
 FROM: Gregory R. Ulreich, Civil/Stormwater Engineer GRU  
 DATE: August 2, 2023  
 RE: Klein Creek Trail – Kuhn to Thunderbird/Bennett  
 Award of a Construction Contract to Schroeder Asphalt Services, Inc.

Engineering Services issued the Invitation for Bids on July 12<sup>th</sup> to place asphalt on the aggregate base previously constructed as Change Order 06 of the Klein Creek Streambank Stabilization – Section I contract. Of the 7 planholders, staff approved 6 for bidding based on the pre-qualification criteria identified in the bid package, but only 4 of those submitted bids. The public bid opening occurred on August 2<sup>nd</sup> at 10:15 AM via Zoom using QuestCDN’s VirtuBid™/vBid™ with the following results:

FIRM	ADDRESS	BASE PRICE
Schroeder Asphalt Services, Inc.	Marengo, IL	\$99,825.00
Maneval Construction	Ingleside, IL	\$103,138.00
A Lamp Concrete Contractors, Inc.	Schaumburg, IL	\$108,994.00
Chicagoland Paving Contractors, Inc.	Lake Zurich, IL	\$110,000.00

As shown in the following table, after this award staff projects that the total cost will remain below the \$500,000.00 as budgeted for this project in the FY24 Capital Improvement Program. The enclosed contract’s terms and conditions requires substantial completion by September 1, 2023.

Engineering’s Estimate of Cost	
Aggregate Base & Storm Sewers	\$66,910
Privacy Fence (Shawnee Drive Properties)	\$23,360
Asphalt Surface*	\$99,825
<b>SUBTOTAL (Expenses-to-Date)</b>	<b>\$190,095</b>
Pedestrian Bridge (Fabrication/Delivery/Installation)	\$125,000
Safety Railing (above retaining wall)	\$25,000
Landscaping (Fine Grading/Topsoil/Seed/Wall)	\$115,000
Pedestrian Crossing @ Kuhn Road	\$15,000
Bennett Drive Concrete Apron	\$5,000
Signage	\$5,000
<b>SUBTOTAL (Estimated Remaining)</b>	<b>\$290,000</b>
<b>TOTAL</b>	<b>\$480,095</b>
* The subject contract of this memo.	

From a review of the references provided, the firm’s reputation within the industry, and staff’s past experience with the firm on the Flexible Pavement Project, staff have concluded that Schroeder Asphalt Services, Inc. is a responsible bidder. Therefore, staff recommends awarding the enclosed contract to Schroeder Asphalt Services, Inc. at the contract unit prices for the estimated total price of \$99,825.00.

cc: Bill Cleveland, Engineering Services Director  
 Brad Fink, Interim Public Works Director (via email)  
 Jon Batek, Finance Director (via email)

Enclosure

# **INVITATION FOR BIDS**

## **KLEIN CREEK TRAIL Kuhn Road to Thunderbird Trail & Bennett Drive**

**SOLICITATION ISSUED DATE:** July 12, 2023  
**ISSUING DEPARTMENT:** Engineering Services  
**PROJECT MANAGER:** Gregory R. Ulreich, P.E.

**ADDENDUM NO.**

---

# Table of Contents

<b>I.</b>	<b>LEGAL NOTICE – INVITATION FOR BIDS</b> .....	<b>4</b>
<b>II.</b>	<b>INSTRUCTIONS FOR BIDDERS</b> .....	<b>5</b>
	1. INVITATION FOR BIDS .....	5
	2. INTERPRETATION OF ESTIMATE OF QUANTITIES .....	5
	3. EXAMINATION OF BID DOCUMENTS AND SITE OF WORK .....	5
	4. PREPARATION OF THE BID .....	6
	5. REJECTION OF BIDS .....	6
	6. BID DEPOSIT .....	6
	7. DELIVERY OF BIDS .....	6
	8. WITHDRAWAL OF BID .....	7
	9. MODIFICATION OF BIDS .....	7
	10. PUBLIC OPENING OF BIDS .....	7
	11. DISQUALIFICATION OF BIDDERS .....	7
	12. RESPONSIBLE BIDDER’S DOCUMENTATION .....	7
	13. BIDDER’S QUESTIONS AND INTERPRETATIONS .....	8
	14. ADDENDA TO THE INVITATION FOR BID .....	8
	15. CONSIDERATION OF BIDS .....	9
	16. AWARD OF OPTIONS .....	9
	17. AWARD OF CONTRACT .....	9
	18. EXECUTION OF THE CONTRACT .....	9
	19. FAILURE TO EXECUTE CONTRACT .....	9
<b>III.</b>	<b>GENERAL TERMS &amp; CONDITIONS</b> .....	<b>10</b>
	1. SCOPE OF SERVICES .....	10
	2. COMPENSATION AND METHOD OF PAYMENT .....	13
	3. CONTRACT TIME .....	15
	4. INSURANCE, INDEMNIFICATION, BONDS AND WARRANTY .....	16
	5. PREVAILING WAGES .....	20
	6. COMPLIANCE WITH THE LAW AND CERTIFICATIONS .....	20
	7. GENERAL PROVISIONS .....	22
	8. NOTICE .....	24
	9. TERMINATION .....	25
<b>IV.</b>	<b>SCHEDULE OF PRICES</b> .....	<b>26</b>
<b>V.</b>	<b>PRICE AND PAYMENT PROCEDURES</b> .....	<b>27</b>
	1. SECTION 109. MEASUREMENT AND PAYMENT .....	27
	2. PAY ITEMS / SCHEDULE OF PRICES .....	27
<b>VI.</b>	<b>STANDARD SPECIFICATIONS</b> .....	<b>29</b>
	1. STANDARD SPECIFICATIONS FOR ROAD AND BRIDGE CONSTRUCTION, ADOPTED APRIL 1, 2016, INCLUDING ALL SUPPLEMENTAL SPECIFICATIONS ADOPTED UP THRU AND TO JANUARY 1, 2021 (SSRBC) .....	29
	2. ILLINOIS URBAN MANUAL, LATEST EDITION .....	30
<b>VII.</b>	<b>SPECIAL PROVISIONS</b> .....	<b>31</b>
	1. ACCESS AND STAGING AREAS .....	31
	2. REPAIR AND PREPARATION OF BASE COURSE .....	31
	3. WORK ZONE TRAFFIC CONTROL AND PROTECTION .....	32
<b>VIII.</b>	<b>PLANS AND DOCUMENTS</b> .....	<b>34</b>

---

1. "KLEIN CREEK TRAIL – KUHN ROAD TO THUNDERBIRD TRAIL & BENNETT DRIVE" .....	34
IX. BIDDER'S PROPOSAL FORM .....	35
X. GOVERNMENTAL CONTRACT COMPLIANCE CERTIFICATIONS .....	37
XI. PRE-QUALIFICATION & REFERENCES .....	40
XII. FORM OF CONTRACT .....	42
1. VILLAGE OF CAROL STREAM'S FORM OF CONTRACT .....	42
XIII. ADDENDA .....	46

---



## I. LEGAL NOTICE – INVITATION FOR BIDS

The Village of Carol Stream, Illinois will receive Sealed Bids for a Public Works Construction contract that will pave approximately 900 lineal feet of 8 foot wide hot-mix asphalt and 3,100 lineal feet of 10 foot wide hot-mix asphalt for the purposes of a multi-use trail. The aggregate base has been rough-graded by others, but it will need to be prepped before paving. All final landscaping will be by others under a different contract.

The deadline to submit Sealed Bids is 10:15 AM CDT on Wednesday, August 2, 2023.

The Village's Department of Engineering Services will be accepting Sealed Bids via the electronic bidding process from QuestCDN's VirtuBid™/vBid™. Bid Procedures, including where to obtain the Bid Packets (digital only; PDF) as well as a list of Planholders, are detailed on the Village of Carol Stream's website via the link below:

<https://www.carolstream.org/services/purchasing-bids>

QuestCDN's process requires that the Village of Carol Stream pre-qualify Bidders before they can access the electronic bidding process. This pre-qualification will be based on the criteria listed in the INSTRUCTIONS FOR BIDDERS, but it will not supersede the process for CONSIDERATION OF BIDS after the PUBLIC OPENING OF BIDS.

A public bid opening will be held immediately after the submittal deadline. Interested parties will have the option of attending either in-person at the Village Hall's Board Room (2<sup>nd</sup> Floor) or virtually (link will be available via the Village's website by the morning of the opening).

The Village of Carol Stream has determined that the services to be provided hereunder are subject to the Prevailing Wage Act, 820 ILCS 130/1-12. The successful Bidder shall not pay less than the prevailing rates of wages to all laborers, workmen, and mechanics performing work under this contract, and shall comply with the requirements of the Illinois Wages of Employees on Public Works Act (820 ILCS 130/1-12).

**\*\*\* END OF LEGAL NOTICE \*\*\***

---

## **II. INSTRUCTIONS FOR BIDDERS**

### **1. INVITATION FOR BIDS**

Bidders will be furnished with an Invitation for Bids stating the location and description of the Work contemplated, the estimated quantities of Work to be performed, the amount of the Bid Deposit, requirements pertaining to labor, and the date, time and place of filing and opening Bids. All documents bound with or attached to the Invitation for Bids shall be considered a part thereof, and shall not be detached or altered.

### **2. INTERPRETATION OF ESTIMATE OF QUANTITIES**

An estimate of quantities of the Work to be done and materials to be furnished under the Specifications is given in the Bid Documents. It is given as a basis for comparison of Bids and the Award of the Contract. The Village and Engineer do not expressly or by implication agree that the actual quantities involved will correspond therewith; nor shall the Bidder plead misunderstanding or deception because of such estimate of quantities pertaining to the Work.

Payment will be based on the actual quantities of Work performed, in accordance with the Contract, at the Contract unit prices. No allowance will be made for any change in anticipated profits due to an increase or decrease in the original estimate of quantities. The Village reserves the right to omit items entirely, or to increase or decrease items as provided in III.1.9 ALTERATIONS, CANCELLATIONS, EXTENSIONS & DEDUCTIONS. and III.2.5 CHANGE ORDERS.

### **3. EXAMINATION OF BID DOCUMENTS AND SITE OF WORK**

The Bidder shall, before submitting a Bid, carefully examine the Bid Documents, Form of Contract, and Contract Bonds. They shall inspect in detail the site of the proposed Work and be familiar with the local conditions affecting the CONTRACT and the detailed requirements of construction. If the Bid is accepted, they will be responsible for all errors in their Bid resulting from their failure or neglect to comply with these instructions. The Village or Engineer will, in no case, be responsible for any change in anticipated profits resulting from such failure or neglect.

All information available to the Village, if any, on subsurface exploration will be made available for examination by prospective Bidders. When the Bid Documents include information pertaining to sub-surface explorations, borings, test pits, and other preliminary investigations, such information is included only for the convenience of the Bidder. The Village or Engineer assumes no responsibility whatever in respect to the sufficiency of the information, and there is no guaranty, either expressed or implied, that the conditions indicated are representative of those existing throughout the Work, or that unanticipated developments may not occur.

When the Bid Documents include information pertaining to the location of underground utility facilities, such information is only included for the convenience of the Bidder. The Village or Engineer assumes no responsibility whatever in respect to the sufficiency or accuracy of the information, or lack of information, relative to the location of underground utility facilities.

---

#### **4. PREPARATION OF THE BID**

Each Bidder shall submit a stipulated sum for furnishing the services as set forth in the Contract Documents contained in the Bid Documents. For the Bid to be complete, it must contain fully-executed versions of the "Bidder's Proposal" form, including fully-executed versions of all submittal items shown on the Bid Submittal Checklist therein. Bids shall be in strict conformity with the Contract Documents and any applicable Addenda.

#### **5. REJECTION OF BIDS**

Bids that contain omissions, erasures, alterations, additions not called for, conditional or alternate Bids, unless called for, irregularities of any kind, or Bids otherwise regular which are not accompanied by the proper Bid Deposit (aka Bid Guaranty) will be rejected as non-responsive. Rejection of a Bid based upon time of completion shall be permitted only when it is specifically stated in the Bid Documents that time of completion will be a basis for Award. However, in accordance with the Village of Carol Stream's Municipal Code of Ordinances Section § 5-8-7, the OWNER shall have the authority to reject all bids, parts of bids or all bids for any one or more supplies or contractual services included in the proposed contract, when the public interest will be served thereby. The Village also reserves the right to waive such technical error as may be deemed best for the interest of the Village.

#### **6. BID DEPOSIT**

Each Bid shall be accompanied by a "Cash Bond" in the sum of not less than five percent (5%) of the amount of the Bid as a guarantee that the Bidder will enter into a contract in accordance with its Bid if awarded the Contract by the Village. The Cash Bond shall be made payable to the "Village of Carol Stream, Illinois". In lieu of a "Cash Bond", a Certified Check, Cashier's Check or Bid Bond in the same amount and drawn in favor of the same payee, will be acceptable. If using a Bid Bond, the Bidder shall complete the Illinois Department of Transportation's Bureau of Local Roads Form BLR 12230 LOCAL AGENCY PROPOSAL BID BOND.

The Bid Deposits of all except the three lowest responsive and responsible bidders on each contract will be returned within fourteen (14) calendar days after the opening of the Bids. The Bid Deposit of the accepted Bidder will be returned after acceptance by the Village of a satisfactory Performance Bond where such bond is required, or upon execution of the Contract where no Performance Bond is required. The remaining Bid Deposits of each Bidder will be returned within fourteen (14) calendar days after the Village Board has awarded the Contract.

#### **7. DELIVERY OF BIDS**

Bids shall be delivered prior to the time and at the place indicated in the LEGAL NOTICE – INVITATION FOR BIDS. Bid's submitted as a hard copy shall be placed in an envelope sealed and plainly marked to indicate its contents with the following information: Bidder's name, address, subject matter and project name as indicated in the LEGAL NOTICE – INVITATION FOR BIDS, as well as the designated date and time of the Bid opening. Only sealed Bids will be accepted.

---

Bids will not be opened unless they are received at the place of letting and prior to the time stated in the LEGAL NOTICE – INVITATION FOR BIDS. It is the sole responsibility of the Bidder to see that the Bid is complete and received on time.

## **8. WITHDRAWAL OF BID**

Permission will be given a Bidder to withdraw a Bid if they make a request in writing, including electronic mail, before the time for opening Bids.

## **9. MODIFICATION OF BIDS**

Modification of bids shall be made in writing, including electronic mail, and must be received at the bid opening office before the time for opening bids. The modifications shall not reveal the total bid price, but shall provide a modified bid unit price and an addition or subtraction amount so that the final bid price can be determined only after the sealed bid is opened.

## **10. PUBLIC OPENING OF BIDS**

Bids will be opened and read publicly at the time and place specified in the Invitation for Bids. Bidders, their authorized agents, and other interested parties are invited to be present.

## **11. DISQUALIFICATION OF BIDDERS**

In accordance with the Village of Carol Stream's Municipal Code of Ordinances Section §5-8-6, the Contract shall be awarded to the lowest, responsible Bidder. In determining the "lowest responsible Bidder", in addition to price, the Village shall consider the following:

- 1) The ability, capacity and skill of the Bidder to perform the contract or provide the service required;
- 2) Whether the Bidder can perform the contract or provide the service promptly, or within the time specified, without delay or interference;
- 3) The character, integrity, reputation, judgment, experience and efficiency of the Bidder.
- 4) The quality of performance of previous contracts or services by the Bidder;
- 5) The previous and existing compliance by the Bidder with laws and ordinances relating to the contract or service;
- 6) The sufficiency of the financial resources and ability of the Bidder to perform the contract or provide the service.
- 7) The quality, availability and adaptability of the supplies, or contractual services to the particular use required;
- 8) The ability of the Bidder to provide future maintenance and service for the use of the subject of the Contract; and
- 9) The number and scope of conditions attached to the Bid.

## **12. RESPONSIBLE BIDDER'S DOCUMENTATION**

No award will be made to any Bidder who cannot satisfy to the Village that they have sufficient ability and experience in this class of work, as well as sufficient capital and equipment to do the

---

job and complete the work successfully within the time named (i.e. responsible). The Village's decision or judgment on these matters shall be final, conclusive, and binding. The Village may make such investigations as it deems necessary. The Bidder shall furnish to the Village, under oath if so required, all information and data the Village may request for the purpose of investigation.

Bidders will not be able to access the electronic bidding module until the Village of Carol Stream marks them as pre-qualified on the plan holder list. In order to be pre-qualified, Bidders must submit the required documentation electronically to the Engineering Services Department at [EngineeringServices@carolstream.org](mailto:EngineeringServices@carolstream.org). Due to the administrative requirements and time constraints for the pre-qualification process to occur prior to the PUBLIC OPENING OF BIDS as dictated by the Village's electronic bid process, the aforementioned inclusion on the plan holder list does not warrant that Bidders are determined to be "responsible" in accordance with DISQUALIFICATION OF BIDDERS. The Village reserves the right to continue its investigation into its determination of whether or not the Bidder is "responsible" as part of its CONSIDERATION OF BIDS.

In order to assist the Village in its determination of the Bidder as "responsible", the Bidder shall provide references of the detail and format dictated under XI PRE-QUALIFICATION & REFERENCES. The Bidder must provide a duplicate of the form for any significant sub-contractor (i.e. those responsible for >25% of the Total Bid Price) to complete and include with its Bid.

### **13. BIDDER'S QUESTIONS AND INTERPRETATIONS**

Should a Bidder find any discrepancies, omissions, ambiguities, or conflicts among the Contract Documents, or be in doubt about their meaning, the Bidder shall advise the Director of Engineering Services, via e-mail at [engineeringervices@carolstream.org](mailto:engineeringervices@carolstream.org), no later than five (5) working days prior to the date for Delivery of Bids. Any questions received after such time shall be answered at the sole discretion of the Village. The Village will not accept any oral questions nor make, or be responsible for, any oral instructions.

The Director of Engineering Services will review the matter raised and, if in their opinion the information sought is not already indicated or specified, or clarification is necessary, will issue an Addendum to the Invitation for Bid. Any failure by the contractor to do so will not relieve them from responsibility for successfully performing the work. The Village assumes no responsibility for any misunderstanding or representations concerning conditions made by its officers or employees prior to the execution of this contract, unless such understanding or representations made are specifically incorporated into the contract. No additional allowance will be granted because of lack of knowledge or such conditions.

### **14. ADDENDA TO THE INVITATION FOR BID**

The Village reserves the right to modify this Invitation for Bid, including the date and time for Delivery of Bids. A copy of such Addendum will be provided to all Bidders known to the Village and will be made available on the Village's website. The Village will not assume any responsibility for the receipt of any Addendum. In all cases it shall be the Bidder's responsibility to obtain any Addenda issued.

---

## 15. CONSIDERATION OF BIDS

The Bids received will be compared on the basis of the summation of the products of the items of Work listed and unit prices offered. In case of discrepancy between the gross sums and the unit prices shown in the Bid, the unit prices shall govern, and any errors found in said gross sums shall be corrected. In awarding Contracts, the Village will, in addition to considering the amounts stated in the Bid, take into consideration the responsibility of the various Bidders per the DISQUALIFICATION OF BIDDERS and RESPONSIBLE BIDDER'S DOCUMENTATION, as well as from other investigations which the Village may elect to make.

## 16. AWARD OF OPTIONS

The Village will decide whether or not to exercise each option at the time of award. The pricing for any awarded options will be included in its evaluation of the total price for award.

## 17. AWARD OF CONTRACT

Except in cases where the Village exercises the right to reject any or all Bids, the Contract will be awarded, as soon as practicable, after the opening of the Bids.

If a Contract is not awarded within forty-five (45) days after the opening of Bids, a Bidder may file a written request with the Village for the withdrawal of their Bid or the Award date may be extended by mutual consent of the Village and Bidder. The Village will have a maximum of five (5) days after the receipt of such request to Award the Contract or release the Bidder from further obligation by return of the Bidder's Bid Deposit.

## 18. EXECUTION OF THE CONTRACT

The successful Bidder shall provide the Village with an executed Contract, an acceptable Performance Bond and Labor & Material Bond, and acceptable insurance certificates, as provided herein, within fifteen (15) calendar days after receipt of the Notice of Award and the Form of Contract, included herein in draft form for reference.

Any changes requested by the successful Bidder to the Form of Contract prior to its execution that are deemed by the Village as unacceptable will be considered as a II.19 FAILURE TO EXECUTE CONTRACT.

## 19. FAILURE TO EXECUTE CONTRACT

Failure on the part of the successful Bidder to provide the documents set forth in the paragraph EXECUTION OF THE CONTRACT, it will be considered as just cause for the rescission of the Award and the forfeiture of the Bid Deposit to the Village, not as a penalty but in payment of liquidated damages sustained as a result of such failure.

**\*\*\* END OF INSTRUCTIONS TO BIDDERS \*\*\***

---

### III. GENERAL TERMS & CONDITIONS

#### 1. SCOPE OF SERVICES.

##### 1.1 ENGAGEMENT OF CONTRACTOR.

The Village hereby engages the Contractor, and the Contractor hereby agrees to perform and/or provide all Work, labor, materials, equipment and services and do all else required to complete the Project in accordance with and as set forth within this Contract and the Contract Documents identified herein.

##### 1.2 CONTRACT AND CONTRACT DOCUMENTS.

The Contract Documents represent the entire and integrated agreement between the Parties hereto and supersedes prior negotiations, representations or agreements, either written or oral. The Contract Documents shall consist of this Contract between the Village and Contractor and those other documents identified and listed on the XII FORM OF CONTRACT and any written modifications issued after execution of the Contract signed by both the Village and Contractor.

##### 1.3 WORK.

The term "Work" means all of the services required by the Contract Documents, and includes all labor, materials, equipment, tools, and other facilities and services provided or to be provided by the Contractor in order to fulfill the Contractor's obligations under the Contract. The Contractor shall provide an adequate number of competently trained and skilled personnel with sufficient supervision to provide the services as set forth in the Contract Documents. The Contractor shall schedule and perform the Work to meet the requirements of the Village. All services shall be provided in compliance with the Contract Documents shall be performed in a good and workmanlike manner. The Contractor shall supervise and direct the Work using Contractor's best skill and judgment. The Contractor shall keep the premises and surrounding area free from accumulation of debris and trash related to the Work.

##### 1.4 MEETING BEFORE WORK COMMENCES.

It is mandatory that the Contractor meet with the Director of Engineering Services or his designee(s) prior to the start of work in order to review the contract specifications, designate the appropriate project contacts, and the manner in which work will be proceeding, among other items.

Upon execution of the contract with the successful bidder, the Village will schedule a meeting with the Contractor. The Contractor shall submit his progress schedule at or before this meeting. In attendance shall be the Contractor's representative on the job, i.e. Construction Superintendent or Foreman. On or before this meeting, the Contractor and Village Engineer shall inspect the work site to determine the existing conditions.

**Purpose.** To discuss and resolve any problems regarding the work prior to the Contractor starting work. This includes the schedule of construction operations and interpretation of the Special Provisions and/or plans.

**Attendance.** Representatives of the Village, the Contractor, significant sub-contractors, and utility company representatives, if utility work or adjustments are required. The Village may request any other person as may be deemed necessary to plan for the work.

Specification information regarding source of materials, who is responsible for testing of

---

materials, what, if any, work will be subcontracted, responsibility for maintaining traffic or detours, and any other coordination issues relating to the work are to be discussed.

A roster will be prepared which will list the names, addresses and telephone numbers of all parties concerned. Emergency contact persons and 24-hour a day phone numbers shall be listed.

## 1.5 CONTROL OF MATERIALS AND INSPECTIONS BY VILLAGE.

### 1.5.1 MATERIAL QUALITY & INCORPORATION INTO THE WORK

It is the intent of the Specifications that all materials shall be new, meet all quality requirements of the Contract, and that they shall be incorporated in such a manner as to produce completed construction which is workmanlike and acceptable in every detail. The cost of collecting and furnishing of samples of all test material shall be borne by the Contractor. The cost of all testing shall be borne by the Village. In lieu of samples and at the Village's sole discretion, the Contractor may provide the Village with letters of certification from each supplier that all materials used in the work comply with the Contract Documents. Only materials which conform to the requirements of these Specifications shall be incorporated in the Work.

### 1.5.2 DEFECTIVE MATERIALS

All materials not conforming to the requirements of the Contract shall be considered as defective and shall be removed from the Work. If in place, they shall be removed by the Contractor at their expense and replaced with acceptable materials. No defective materials, the defects of which have been subsequently corrected, shall be used until approval has been given. Upon failure of the Contractor to comply forthwith with any written order of the Village pursuant to the provisions of this Contract, the Village shall have authority to remove and replace defective materials and to deduct the cost of removal and replacement from any moneys due or to become due the Contractor.

### 1.5.3 INSPECTION OF COMPLETED WORK

The Village shall have the right to inspect any services or completed work specified herein. Upon a determination that such work has not been completed in accordance with the Contract, the Village may order that such corrective action be taken as necessary to complete the Work.

## 1.6 PUBLIC SAFETY AND CONVENIENCE:

The Contractor is solely responsible for ensuring that all work performed under this agreement is conducted in a safe manner and that all employees performing work for the contractor have received safety training on a regular and consistent basis and is in compliance with OSHA and other regulatory provisions.

## 1.7 DAMAGES TO PUBLIC OR PRIVATE PROPERTY.

Any damage of public or private property caused by the Contractor's operations shall be resolved with the property owner within ten (10) days after damage occurs to the satisfaction of the Village. The Contractor shall inform the Village of any damage caused by the Contractor's operation on the day such damage occurs. Should the damage not be rectified within the time frame agreed upon or to the satisfaction of the Village, the Village reserves the right to repair or replace that which was damaged or assess the Contractor such cost as may be reasonable and related to damaged caused by the Contractor, and deduct these costs from any payment due the Contractor.

---



#### 1.8 SUBLETTING.

Contractor shall not assign, transfer, convey, sublet, subcontract or otherwise dispose of this contract or any or all of his right, title, or interest therein, or his power to execute such contract, to any other person, firm, or corporation, without the prior written consent of an authorized representative of the Village of Carol Stream. In no case shall consent relieve the Contractor from his obligations under this Contract or change the terms of this Contract.

Notwithstanding consent to subcontract approved by the Village, the Contractor shall perform with the Contractor's own organization, work amounting to not less than 50 percent of the total contract cost, and with materials purchased or produced by the Contractor. The Village may request the Contractor provide proof that any proposed subcontractor has the experience, ability, and equipment the work requires.

The Village may order the Contractor to remove a subcontractor who does not perform satisfactory work or does not possess the integrity, experience, ability, and equipment the work requires in accordance with the terms and conditions of this contract. The Contractor shall comply at once and shall not employ the subcontractor for any further work under this contract.

#### 1.9 ALTERATIONS, CANCELLATIONS, EXTENSIONS & DEDUCTIONS.

The Village reserves the right to alter the program, add such work as may be necessary, and delete such work that might not be necessary to accomplish such changes that the Village staff feels appropriate in order to develop a program that is within available funding capabilities. The procedures for alterations or changes in quantities shall generally follow Section 104.02 of the Standard Specifications for Road and Bridge Construction.

#### 1.10 REPRESENTATION BY THE CONTRACTOR.

The Contractor represents that it is financially solvent, has the necessary resources, is sufficiently experienced and competent to perform and complete the execution of the Work necessary to complete the Project.

#### 1.11 WORK HOURS.

The Contractor's operations will be considered exempt from the Village's Code addressing noise pollution per the exemption listed under §14-2-16(H)(4) in order to maximize the amount of time the Contractor has for performing the Work "in-the-dry".

However, the Contractor's equipment during the hours that would otherwise be prohibited shall be designed or operated in a manner such that the noise pollution reaching residential property is below 61 dB(A). Additional restrictions on the bypass pumping operations are detailed in **Error! Reference source not found. Error! Reference source not found..**

#### 1.12 PERMITS.

The Village has or will obtain the following Federal, State and local permits, which includes the payment of all associated fees, required to complete the Work. The Contractor is therefore obligated to ensure that its own means and methods, when not specifically prescribed within these Contract Documents, adhere to the permit conditions contained therein.

#### 1.13 USE OF FIRE HYDRANTS.

Under no circumstances shall water for construction purposes be drawn from any public or private fire hydrant. Water for construction purposes is only available to the Contractor from the

---

Public Works Facility, 124 Gerzevske Lane, Carol Stream, IL 60188. Access to the Facility is restricted, so the Contractor shall coordinate with the Director of Public Works ahead of time. The water is available at no additional cost when used in conjunction with this Work.

Fire hydrants shall be accessible at all times to the Fire Department. No material or other obstructions shall be placed within ten (10) feet of a fire hydrant.

## 2. COMPENSATION AND METHOD OF PAYMENT.

### 2.1 CONTRACT AMOUNT & PROGRESS PAYMENTS.

The Village agrees to pay the Contractor for the performance of the Work of this Contract for the completion of the Project, subject to additions and deductions as provided in the Contract Documents, the Contract Sum as shown on IV SCHEDULE OF PRICES. Contractor may invoice the Village for Work completed at intervals not to exceed a monthly basis. Such progress payments will be made by the Village for all Work completed in a satisfactory manner and in accordance with the specifications stated herein, in accordance with the Illinois Prompt Payment Act. Ten per cent (10%) of each progress payment will be withheld by the Village until Substantial Completion.

### 2.2 APPLICATION FOR PAYMENTS & WAIVERS OF LIEN.

The Contractor shall submit an application for payment in an approved format ("Application for Payment") to the Village for payments under this Contract. The Village requires for each Application for Payment, a properly completed Contractor's Affidavit setting out, under oath, the name, address and amount due or to become due, of each subcontractor, vendor, or party included in that payment.

#### 2.2.1 PARTIAL OR FULL WAIVER OF LIEN

For every party listed, the Contractor shall also provide a full or partial waiver of lien, as appropriate, before a payment will be made to the Contractor. The Contractor's partial or final waiver of lien must be included. Payment certificates shall not be issued by the Village or its designated representative without such lien waiver and Contractor's sworn statements unless they are conditioned upon such waivers and statements.

#### 2.2.2 FINAL RELEASE AND WAIVER OF ALL LIENS

Upon satisfaction of the terms and conditions of the Contract and prior to final payment, the Contractor agrees to provide the Village with a final release and waiver of all liens covering all Work performed under the Contract relative to the Project including all Work performed by all subcontractors. Said final release and waiver of all liens shall identify and state that all contractors and subcontractors have been paid in full and there are no contract balances outstanding and owed to any such contractors or subcontractors.

#### 2.2.3 FINAL PAYMENT

The Village may withhold final payment until all services, reports, and/or other deliverables specified herein have been completed in a form satisfactory to the Village. Final payment will be made by the Village only upon inspection of the Work, completion of any punch list items, and after receipt of final release and waiver of liens.

### 2.3 AUTHORITY TO WITHHOLD PAYMENT.

The Village may decline to pay an invoice, in whole or in part, to the extent Village decides it is necessary to protect it from loss due to any of the following:

---

- (i) Breach by Contractor of any of its obligations under the Contract (including the costs to Village of remedying the breach {whether by replacing or repairing the Work or otherwise} and all other costs directly attributable to other services that are required to be performed in connection with remedying such breach);
- (ii) Third-party claims filed or reasonable evidence indicating probable filing of such claims;
- (iii) Contractor's failure to properly pay subcontractors or to properly pay for equipment, materials or labor;
- (iv) Damage to Village's or another's project where such damage arises out of the actual or alleged willful misconduct or negligent acts or omissions of Contractor and subcontractors or their agents, employees or any other person to whom, directly or indirectly, Contractor or any subcontractor may be liable;
- (v) Reasonable evidence that the Work will not be completed within the time requirements specified in the Contract or for the balance of the Contract Sum or Contract Price then unpaid;
- (vi) Unsatisfactory Work performed; or
- (vii) Incomplete, inaccurate, or unauthorized billing.

#### 2.4 RECORDS.

The Contractor shall maintain records showing actual time devoted, type of Work performed per classification and costs incurred, and shall permit the Village to inspect and audit all data and records of the Contractor for Work done pursuant to this Contract.

#### 2.5 CHANGE ORDERS.

- (i) Changes in the Work may only be accomplished by a Change Order signed by the Village Manager to change the Work, Contract sum or Contract time.
- (ii) Where a Change Order or a series of Change Orders authorize or necessitate an increase or decrease in either the cost of the Project totaling \$10,000 or more or the time of completion of the Project by 30 days or more, a written determination must be prepared and signed by the Village or its designee stating that the circumstances necessitating the change in performance were not reasonably foreseeable at the time the Contract was signed; or the change is germane to the original Contract as signed; or the Change Order is in the best interest of the and authorized by law in accordance with 720 ILCS 5/33E 9. In addition, any Change Order on the Project that authorizes or necessitates any increase in the total amount of the Contract that is 50% or more of the original Contract Sum or Contract Price or that authorizes or necessitates any increase in the price of a subcontract under the Contract that is 50% or more of the original subcontract price, then the portion of the Contract that is covered by the Change Order must be resubmitted for bidding in accordance with the Public Works Contract Change Order Act (50 ILCS 525/1 et seq.).

#### 2.6 TAXES.

Contractor acknowledges that the Village is a tax exempt entity under the laws of the State of Illinois and that the Village shall, as part of its undertakings under this Contract, provide to the Contractor all certificates of exemptions and tax exempt numbers needed to entitle Contractor to purchase material and other items to be used on the Work or incorporated into the Work on a tax-exempt basis, said exemptions specifically to include but not be limited to the "Illinois Retailer's

Occupation Tax” (sales tax). Contractor shall warrant that all material costs and scheduled values have been calculated so as to give the Village its full benefit of its tax-exempt status, and Contractor shall require that all subcontracts include a requirement that subcontractors purchase materials so as to give the Village the full benefit of its tax exempt status. The Village shall not be liable for, and shall be entitled to a credit against the Contract Sum or Contract Price for any sales tax paid by Contractor or any subcontractor of any tier which is shown to have been charged to the Village as part of the Contract Sum or Contract Price, as a component of the schedule of values, as a unit price, or otherwise.

## **2.7 ADDITIONAL SERVICES.**

The Contractor acknowledges and agrees that the Village shall not be liable for any costs incurred by the Contractor in connection with any services provided by the Contractor that are outside the scope of this Contract (“Additional Services”), regardless of whether such Additional Services are requested or directed by the Village, except upon the prior written approval of the Village.

## **2.8 PROMPT PAYMENT ACT.**

All payments made under this Contract shall be made in conformance with the provisions of the Local Government Prompt Payment Act. 50 ILCS 505/1 et seq.

# **3. CONTRACT TIME.**

## **3.1 COMMENCEMENT.**

The Work on this Contract shall commence upon the issuance of a written notice to proceed. The Contractor is responsible for ensuring that the Work continue expeditiously from that date in accordance with the Time of Performance noted herein or as otherwise set forth in the notice to proceed.

## **3.2 TIME OF PERFORMANCE.**

Time is of the essence with regard to the performance of the Work related to this Contract. Failure to meet the time frame of the Contract shall be considered an occasion of default under the Contract. The Contract Time shall not be increased without the express written consent of the Village.

III.3.3 SUBSTANTIAL COMPLETION.

**September 1, 2023**

## **3.3 SUBSTANTIAL COMPLETION.**

Substantial Completion shall mean the stage in the progress of the Work when the Work is sufficiently complete so that the Village can utilize the Work for its intended use.

## **3.4 LIQUIDATED DAMAGES.**

Should the Contractor fail to complete the work within the working days stipulated in the contract, or on or before the completion date stipulated in the contract, or within such extended time as may have been allowed, the Contractor shall be liable and shall pay to the Village the rate of \$200 per working day, not as a penalty, but as liquidated damages for each working day of overrun in the contract time or beyond such extended time as may have been allowed. The liquidated damages for failure to complete the Contract on time are approximate, due to the

---

impracticality of calculating and providing actual delay costs. This rate establishes the cost of delay to account for administration, engineering, inspection, and supervision during periods of extended and delayed performance. The costs of delay represented by this rate are understood to be a fair and reasonable estimate of the costs that will be borne by the Village during extended and delayed performance by the Contractor of the Work, remaining incidental Work, correction of Work improperly completed, or repair of Work damaged as a result of the Contractor. The liquidated damage amount specified will accrue and be assessed until Final Completion of the total physical Work of the Contract even though the Work may be Substantially Complete. The Village will deduct these liquidated damages from any monies due, or to become due, to the Contractor from the Village.

## 4. INSURANCE, INDEMNIFICATION, BONDS AND WARRANTY.

### 4.1 INSURANCE.

The Contractor shall carry and maintain insurance of the types and in the amounts set forth below and, if necessary, commercial umbrella insurance, and provide the Village with certificates of insurance and endorsements prior to commencing with Work. All such insurance shall be carried with companies satisfactory to the Village and be rated at least A VII by A.M. Best Company.

#### 4.1.1 WORKER'S COMPENSATION COVERAGE

STATUTORY coverage for all persons whom the Contractor may employ directly or through subcontractors in carrying out the Work under this Contract.

#### 4.1.2 EMPLOYER'S LIABILITY

- a) \$1,000,000 minimum liability each accident for bodily injury by accident.
- b) \$1,000,000 minimum liability each employee for bodily injury by disease.

#### 4.1.3 COMMERCIAL GENERAL LIABILITY COVERAGE

Bodily injury and property damage (including Premises-Operations; Independent Contractor's; Products and Completed Operations: Broad Form Property Damage) with a limit of not less than \$5,000,000 each occurrence. If such CGL insurance contains a general aggregate limit, it shall apply separately to this project/location.

CGL insurance shall be written on Insurance Services Office (ISO) occurrence form CG 00 01 10 93, or a substitute form providing equivalent coverage, and shall cover liability arising from premises, operations, independent contractors, products-completed operations, personal injury and advertising injury, and liability assumed under an insured contract (including the tort liability of another assumed in a business contract).

The Village and its officers, agents, and employees shall be named as additional insureds (the Additional Insureds) under the CGL, using ISO additional insured endorsement CG 20 10 or a substitute providing equivalent coverage, and under the commercial umbrella, if any. This insurance shall apply as primary insurance with respect to any other insurance or self-insurance afforded to the Additional Insureds. Any insurance or self-insurance maintained by the Additional Insureds shall be excess of the Contractor's insurance and shall not contribute with it.

There shall be no endorsement or modification of the CGL limiting the scope of coverage for

liability arising from pollution, explosion, collapse, or underground property damage.

4.1.4 CONTINUING COMPLETED OPERATIONS LIABILITY INSURANCE

The Contractor shall maintain commercial general liability (CGL) and, if necessary, commercial umbrella liability insurance with a limit of not less than \$5,000,000 each occurrence for at least three years following Substantial Completion of the Work.

Continuing CGL insurance shall be written on ISO occurrence form CG 00 01 10 93, or substitute form providing equivalent coverage, and shall, at minimum, cover liability arising from products-completed operations and liability assumed under an insured contract. Continuing CGL insurance shall have a products-completed operations aggregate of at least two times its each occurrence limit.

Continuing commercial umbrella coverage, if any, shall include liability coverage for damage to the insured's completed work equivalent to that provided under ISO form CG 00 01.

4.1.5 COMMERCIAL AUTOMOBILE LIABILITY COVERAGE

The Contractor shall maintain, until the completion and acceptance of the Work under this Contract, insurance to protect from claims for bodily injury and property damage which may arise from the use of motor vehicles, owned hired and non-owned, engaged in various operations under this Contract. The Village its officers, agents, and employees shall be named as an Additional Insureds.

Limits:	Bodily Injury and Property Damage each accident	<u>\$2,000,000</u>
---------	----------------------------------------------------	--------------------

Business auto insurance shall be written on Insurance Services Office (ISO) from CA 00 01, CA 00 05, CA 00 12, CA 00 20, or a substitute form providing equivalent liability coverage. If necessary, the policy shall be endorsed to provide contractual liability coverage equivalent to that provided in the 1990 and later editions of CA 00 01.

4.1.6 UMBRELLA EXCESS LIABILITY

The Village and its officers, agents and employees shall be named as an additional insured.

Limits:	Liability Insurance:	\$1,000,000
		Over Primary Commercial General \$10,000 Retention

4.1.7 PROFESSIONAL LIABILITY COVERAGE (NOT REQUIRED)

4.1.8 GENERAL INSURANCE PROVISIONS

The Contractor shall have the following obligations with regard to insurance coverage for the Work under the Contract:

Prior to beginning work, Contractor shall furnish the Village with a certificate(s) of insurance and applicable policy endorsement(s), executed by a duly authorized representative of each insurer, showing compliance with the insurance requirements set forth herein. All certificates of

---

insurance required to be obtained by the Contractor shall provide that coverages under the policies named shall not be cancelled, modified, reduced or allowed to expire without at least Thirty (30) Days prior written notice given to the Village. All certificates evidencing coverage extended beyond the date of final payment shall be provided at the time of the the final Pay Request. All certificates of insurance shall name the Village and its officers, agents and employees as Additional Insureds on a primary non-contributory basis. The actual additional insured endorsement shall be attached to the certificate of insurance.

All insurance required of the Contractor shall state that it is Primary and Non-Contributory Insurance as to all additional insureds with respect to all claims arising out of operations by or on their behalf. If additional insureds have other applicable insurance coverages, those coverages shall be regarded as on an excess or contingent basis.

If Contractor's liability policies do not contain the standard ISO separation of insured's provision, or a substantially similar clause, they shall be endorsed to provide cross-liability coverage.

The Contractor shall require that every subcontractor of any tier obtain insurance of the same character as that required of Contractor, naming the same Additional Insureds and subject to the same restrictions and obligations as set forth for the Contractor's insurance in the Contract Documents.

Under no circumstances shall the Village or any Additional Insureds be deemed to have waived any of the insurance requirements of this Contract by any act or omission, including, but not limited to:

- a. Allowing Work by Contractor or any subcontractor of any tier to start before receipt of Certificates of Insurance;
- b. Failure to examine, or to demand correction of any deficiency, of any certificate of insurance received.

The Contractor agrees that the obligation to provide insurance is solely the Contractor's responsibility and cannot be waived by any act or omission of the Village or any Additional Insureds.

The purchase of insurance by the Contractor under this Contract shall not be deemed to limit the liability of the Contractor in any way, for damages suffered by the Village in excess of policy limits or not covered by the policies purchased.

The Contractor shall notify the Village, in writing, of any possible or potential claim for personal injury or property damage arising out of the Work of this Contract promptly whenever the occurrence giving rise to such a potential claim becomes known to the Contractor.

The Contractor further agrees to cause contractual liability endorsements to be issued by the insurance companies and attached to the above-mentioned policies to include under the coverage therein an extended obligation on the part of the insurers to insure against Contractor's contractual liability hereunder and to indemnify the Village and its agents against loss, liability, costs,

expenses, attorneys' fees and court costs, and further agrees that said coverage shall be afforded therein against all claims arising out of the operation of any structural work law or law imposing liability arising out of the use of scaffolds, hoists, cranes, stays, ladders, supports or other mechanical contrivances. Endorsements to the certificates of insurance shall include as named additional insured the Village and its officers, agents and employees.

#### 4.2 INDEMNIFICATION.

To the fullest extent permitted by Illinois law, Contractor shall indemnify, defend and hold harmless the Village of Carol Stream and its officers, employees and agents (collectively "Indemnitees"), from lawsuits, actions, costs (including attorneys' fees), claims or liabilities of any character (collectively "Damages") caused by, resulting from, arising out of or occurring in connection with the Contractor's performance of the Work under this Contract, provided that any such lawsuit, action, cost, claim or liability is attributable to bodily injury, sickness, disease, or death, or to injury to or destruction of tangible property, but only to the extent caused by the negligent act or omission, intentional misconduct, or breach of applicable law of the Contractor or anyone or entity directly or indirectly employed by Contractor for whose acts Contractor may be liable. Under no circumstance shall Contractor's indemnification apply to Damages caused by the sole negligence of the Indemnitees. In connection with any such claims, lawsuits, actions or liabilities, the Village, its officers, agents, employees, representatives and their assigns shall have the right to defense counsel of their choice. The Contractor shall be solely liable for all costs of such defense and for all expenses, fees, judgments, settlements and all other costs arising out of such claims, lawsuits, actions or liabilities. Contractor shall protect, indemnify, and hold and save harmless the Village from and against any and all claims, costs, causes, actions and expenses including but not limited to legal fees, incurred by reason of Contractor's breach of any obligations under or Contractor's default of any provision of the Contract Documents.

#### 4.3 PERFORMANCE AND LABOR & MATERIAL BONDS.

The Contractor shall furnish to the Village at the time of execution of the Contract, a Performance Bond and a Labor & Material Bond, each in the full amount of the Contract Sum securing the full and faithful performance of the Contract and the payment for all labor and material furnished by the Contractor or anyone furnishing such under the Contractor's contract or a subcontract of any tier. Said bonds shall be in a form provided by the Village or otherwise acceptable to the Village. Said bonds shall be written by a surety authorized to do surety business in Illinois and acceptable to the Village, in its sole and absolute discretion. The cost thereof shall be paid by the Contractor.

#### 4.4 WARRANTY.

Contractor warrants to the Village that:

- (i) Materials and equipment furnished under this Contract will be new and of good quality unless otherwise required or permitted by the Contract Documents;
- (ii) The Work will be free from defects in materials and workmanship under normal use and service for one year from Final Completion of the Project and all deficiencies shall be corrected by the Contractor immediately upon notification from the Village.

Under this warranty, Contractor is obligated to either repair or replace, at its option, defective equipment, materials, software, or any other equipment and/or materials provided and installed on

---



the Project at its own expense. Contractor warrants that replacement or repaired equipment, materials, software, or any other provided and installed equipment and/or materials furnished hereunder shall be in accordance with the current industry standards and that all labor shall be performed in a workmanlike manner and in accordance with industry standards.

Any warranties provided under the Contract Documents shall not preclude the Village's right to bring any action for Contractor's breach of this Contract. Work not conforming to these requirements, including substitutions not properly approved and authorized, may be considered defective. Contractor shall finish satisfactory evidence as to the kind and quality of materials and equipment.

Contractor shall pass-through to the Village all manufacturers' warranties for the equipment and supplies installed on the Project. Contractor shall provide written evidence satisfactory to the Village prior to the commencement of the Work on the Project evidencing all equipment and/or product warranties that will pass-through to the Village.

## **5. PREVAILING WAGES**

### **5.1 PREVAILING WAGES.**

This Contract calls for the construction of a "public work" within the meaning of the Illinois Prevailing Wage Act, 820 ILCS 130/0.01 et seq. ("the Act"). The Contractor and all subcontractors are required to pay wage rates in accordance with the Act to all laborers, workers and mechanics.

The enactment of Public Act 100-1177, which took effect June 1, 2019, relieves local units of government from the former requirement of passing a prevailing wage ordinance, publishing it and filing it with the Illinois Department of Labor. The prevailing wage schedules for each county in the state are now ascertained by IDOL and published on its website.

The Contractor and all subcontractors are responsible for checking the IDOL's website for revisions to the prevailing wage rates. In the event that the IDOL should revise the prevailing rate of wages, then the revised rates shall apply to this Contract. In no case shall any revision in the rates of prevailing wages result in an increase in the total Contract Sum.

The Contractor certifies that it has not been found by the Illinois Department of Labor to be in violation of its obligations under the Prevailing Wage Act within the last two years and is not otherwise barred from participating and/or entering into this Contract under Section 130/11a of the Act (820 ICLS 130/11a).

### **5.2 RECORDS AND CERTIFIED PAYROLL.**

The Contractor and each of its subcontractors participating on the Project shall make and keep those records required under Section 5 of the Prevailing Wage Act. The enactment of Public Act 100-1177, which took effect June 1, 2019, required IDOL to create an electronic database of certified payrolls where the Contractor shall submit certified payrolls directly online rather than filing them with the Village.

## **6. COMPLIANCE WITH THE LAW AND CERTIFICATIONS.**

### **6.1 COMPLIANCE WITH GOVERNMENTAL REGULATIONS.**

Contractor shall comply with and perform all Work required under the Contract Documents in

conformance with all applicable federal, state and local laws, regulations and/or ordinances. This provision shall not be limited to those statutes, ordinances and/or regulations referred to herein.

#### **6.2 CERTIFICATION TO ENTER INTO PUBLIC CONTRACTS.**

Contractor certifies that it is not barred from contracting with any unit of state or local government as a result of a violation of either Section 33E-3 or 33E-4 of the Illinois Criminal Code or any similar offense of any State of the United States which contains the same elements as the Illinois offenses of bid-rigging or bid rotating. Contractor shall execute the attached Certification at EXHIBIT "2".

#### **6.3 PAYMENTS TO THE ILLINOIS DEPARTMENT OF REVENUE.**

Contractor certifies that it is not delinquent in the payment of any taxes to the Illinois Department of Revenue. Contractor shall execute the attached Certification at EXHIBIT "3".

#### **6.4 ILLINOIS DRUG FREE WORKPLACE ACT.**

In the event the Contractor has twenty-five (25) or more employees at the time of the execution of this Contract, Contractor agrees to provide a drug-free workplace in accordance with the Drug Free Workplace Act, 30 ILCS 580/1 et seq. Contractor shall execute the attached Certification at EXHIBIT "4".

#### **6.5 SUBSTANCE ABUSE PREVENTION ON PUBLIC WORKS PROJECTS.**

Contractor certifies that it has in place a written program which meets or exceeds the program requirements of the Substance Abuse Prevention on Public Works Projects Act (820 ILCS 265/1 et seq.), and will provide a copy thereof to the Village. Contractor shall execute the attached Certification at EXHIBIT "5".

#### **6.6 ILLINOIS PUBLIC WORKS EMPLOYMENT DISCRIMINATION ACT.**

Contractor certifies that this contract shall be performed in compliance with all requirements of the Illinois Public Works Employment Discrimination Act, 775 ILCS 10/0.01 et seq.

#### **6.7 NON-DISCRIMINATION: HUMAN RIGHTS ACT.**

Contractor hereby agrees that this Contract shall be performed in compliance with all requirements of the Illinois Human Rights Act, 775 ILCS 5/1-101 et seq., and that the Contractor and its subcontractors shall not engage in any prohibited form of discrimination in employment as defined in the Act. The Contractor shall maintain, and require that its subcontractors maintain policies of equal employment opportunity which shall prohibit discrimination against any employee or applicant for employment on the basis of race, religion, color, sex, national origin, ancestry, citizenship status, age, marital status, physical or mental disability unrelated to the individual's ability to perform the essential functions of the job, association with a person with a disability, or unfavorable discharge from military service. Pursuant to Section 2-105 (A)(4) of the Illinois Human Rights Act, the Contractor and each subcontractor shall adopt and maintain a written sexual harassment policy.

#### **6.8 SEXUAL HARASSMENT POLICY.**

Contractor certifies that pursuant to Section 2-105 (A)(4) of the Illinois Human Rights Act, the Contractor and each authorized subcontractor has adopted and maintains a written sexual harassment policy that shall include at a minimum, the following:

---

- (i) The illegality of sexual harassment;
- (ii) The definition of sexual harassment under State law;
- (iii) A description of sexual harassment, utilizing examples;
- (iv) The Contractor's/subcontractor's internal complaint process, including penalties;
- (v) The legal recourse, investigative and complaint process available through the Department and Commission;
- (vi) Directions on how to contact the Department and the Commission; and
- (vii) Protection against retaliation as provided by Section 6-101 of the Illinois Human Rights Act.

A copy of these policies shall be provided to the Village on request.

## **7. GENERAL PROVISIONS.**

### **7.1 AMENDMENT.**

No amendment or modification to this Contract shall be effective until it is reduced to writing and approved and executed by the Village and Contractor in accordance with all applicable statutory procedures.

### **7.2 ASSIGNMENT.**

This Contract may not be assigned by the Village or the Contractor without the prior written consent of the other party.

### **7.3 TIME IS OF THE ESSENCE.**

Time is of the essence for the performance of the Work and the completion of the Project.

### **7.4 VENUE AND GOVERNING LAW.**

This Contract shall be governed by the laws of the State of Illinois and venue shall be fixed in the Eighteenth Judicial Circuit of DuPage County, Illinois.

### **7.5 ARBITRATION AND MEDIATION.**

Notwithstanding any inconsistent or contrary provision in any other provision of the Contract Documents, no claim or dispute arising under this Contract shall be subject to arbitration unless the Parties mutually agree on a submission to arbitration, which submission shall be in writing and signed by the Parties and shall set forth a specific statement of the nature of the dispute and shall contain an express statement on the limitations of the powers of the arbitrator. The Parties mutually agree that in the absence of such submission, arbitration cannot be demanded or compelled by either party.

### **7.6 NO DAMAGES FOR DELAY.**

The Contractor agrees that in the event of delay for any reason caused by any party or person, it will be fully compensated for the delay by an extension of time to complete the Contract and will not seek additional compensation.

### **7.7 NO WAIVER BY PAYMENT.**

Notwithstanding any language in the Contract Documents to the contrary, Village shall not be deemed to waive any claim or right to assert a claim by making any progress payment or final

---

payment.

#### **7.8 NO WAIVER OF SUBROGATION.**

Notwithstanding any inconsistent or contrary provision in the Contract Documents to the contrary or inconsistent with this provision, the Village shall not be deemed to have waived any right of subrogation which it, its insurance carrier, any self-insurance risk pool or risk management association, (or any combination of these entities) may have against the Contractor, the Engineer, the Architect or any Subcontractor of any tier for any damage caused by Contractor, the Engineer, the Architect or any Subcontractor of any tier, to the Village or Village's property.

#### **7.9 FREEDOM OF INFORMATION ACT.**

The Illinois Freedom of Information Act (FOIA) has been amended and effective January 1, 2010, adds a new provision to Section 7 of the Act which applies to public records in the possession of a party with whom the Village has contracted. The Village will have only a very short period of time from receipt of a FOIA request to comply with the request, and there is a significant amount of work required to process a request including collating and reviewing the information. The Contractor acknowledges the requirements of FOIA and agrees to comply with all requests made by the Village for public records (as that term is defined by Section 2(c) of FOIA) in the undersigned's possession and to provide the requested public records to the Village within two (2) business days of the request being made by the Village. The undersigned agrees to indemnify and hold harmless the Village from all claims, costs, penalty, losses and injuries (including but not limited to, attorneys' fees, other professional fees, court costs and/or arbitration or other dispute resolution costs) arising out of or relating to its failure to provide the public records to the Village under this Contract.

#### **7.10 LIMITATION OF LIABILITY PROVISIONS.**

Notwithstanding any inconsistent or contrary provision in the Contract Documents, the Village shall not be deemed to have agreed to or consented to any limitation of liability provision applicable to the Contractor.

#### **7.11 AUTHORITY TO EXECUTE.**

##### **7.11.1 THE VILLAGE.**

The Village hereby warrants and represents to the Contractor that the persons executing this Contract on its behalf have been properly authorized to do so by its corporate authorities.

##### **7.11.2 THE CONTRACTOR.**

The Contractor hereby warrants and represents to the Village that the persons executing this Contract on its behalf have the full and complete right, power, and authority to enter into this Contract and to agree to the terms, provisions, and conditions set forth in this Contract and that all legal actions needed to authorize the execution, delivery, and performance of this Contract have been taken.

#### **7.12 ENTIRE AGREEMENT.**

This Contract constitutes the entire agreement between the Parties to this Contract and supersedes all prior agreements and negotiations between the Parties, whether written or oral, relating to the subject matter of this Contract.

---

### 7.13 COUNTERPART EXECUTION.

This Contract may be executed in several counterparts, each of which, when executed, shall be deemed to be an original, but all of which together shall constitute one and the same instrument.

### 7.14 PATENT AND COPYRIGHT.

The Contractor and its Surety shall pay for all royalties and/or license fees and assume all costs incident to the use in performance of the Work or the incorporation in the Work of any invention, design, process, product or device which is subject to patent or copyrights held by others, and, additionally, shall defend all suits or claims for infringements of any patent or invention right or copyrights involved in the items furnished hereunder. The Contractor and its Surety shall hold and save the Village and its officers, agents, servants and employees harmless from liability of any nature or kind, including cost and expenses, for, or on account of, any patented or unpatented invention, process, article or appliance furnished in the performance of the Contract including its use by the Village, unless otherwise specifically stipulated and agreed to in this Contract.

### 7.15 ADVERTISEMENT.

The Contractor and subcontractor shall not display any signs, posters, or other advertising matter in or on the Work or on or around the Village property without the specified approval in writing by the Village. In addition, no advertising copy mentioning the Village or quoting the opinions of any of its employees may be released unless such copy is approved in writing by the Village before release.

## 8. NOTICE.

### 8.1 NOTICES REQUIRED OR PERMITTED

All notices required or permitted to be given under this Contract shall be in writing and shall be delivered (1) personally, (2) by a reputable overnight courier, or by (3) by certified mail, return-receipt requested, and deposited in the U.S. Mail, postage prepaid. Unless otherwise expressly provided in this Contract, notices shall be deemed received upon the earlier of: (a) actual receipt; (b) one business day after deposit with an overnight courier, as evidenced by a receipt of deposit; or (c) four business days following deposit in the U.S. mail, as evidenced by a return receipt. By notice complying with the requirements of this Section 8, each party shall have the right to change the address or the addressee, or both, for all future notices and communications to the other party, but no notice of a change of addressee or address shall be effective until actually received.

Notices and communications to the Village shall be addressed to, and delivered at, the following addresses:

Village of Carol Stream  
500 N. Gary Avenue  
Carol Stream, Illinois 60188  
Attn: Director of Engineering Services

Notices and communications to the Contractor shall be addressed and delivered to the person and address for the Contractor identified in 0

BIDDER'S PROPOSAL FORM. To the extent the Contractor desires notices to be sent to a different person and/or address than set forth therein, any such alternative contact person and/or address shall be provided to the Village in writing.

## 9. TERMINATION.

### 9.1 TERMINATION FOR DEFAULT.

The Village may cancel the Contract for breach, as determined by the Village, for items such as, but not limited to: failure to meet insurance requirements, failure to meet required performance or progress standards as described herein, or if the quality or level of service is unsatisfactory to the Village. This cause for breach may include any cessation or diminution of service which, in the opinion of the Village, is not in its best interest or any failure to comply with the terms of the Contract.

The Village shall notify the Contractor in writing of any Contract breach. The Contractor shall remedy the breach within ten (10) calendar days. If the breach is not remedied in ten (10) calendar days, the Village may cancel the Contract by giving thirty (30) days' notice in writing of its intention to cancel this Contract.

In the event of cancellation for breach, the Contractor shall be paid only for Work satisfactorily performed up to the date of cancellation.

In the event of early termination or cancellation for any cause, no payment for services performed will be made until and unless any necessary reports and/or deliverables have been provided.

### 9.2 TERMINATION FOR CONVENIENCE.

The Village shall have the ability to terminate the Contract with thirty (30) days advance notice in its sole and absolute discretion. In the event of termination, Contractor shall be entitled to compensation for Work satisfactorily completed up until the point of termination.

**\*\*\* END OF GENERAL TERMS AND CONDITIONS \*\*\***

---

#### IV. SCHEDULE OF PRICES

***Complete this form only if NOT submitting via the electronic bidding process***					
No.	Items	Unit	Qty	Unit \$	Total \$
2.1	MOBILIZATION	L.SUM	1		
2.2	PREPARATION OF BASE	L.SUM	1		
2.3	AGGREGATE BASE REPAIR	TON	50		
2.4	BITUMINOUS MATERIALS (PRIME COAT)	LBS	8,000		
2.5	HMA SURFACE COURSE, 3 INCHES	TON	713		
<b>TOTAL BASE BID PRICE</b>					
***Complete this form only if NOT submitting via the electronic bidding process***					

## V. PRICE AND PAYMENT PROCEDURES

### I. SECTION 109. MEASUREMENT AND PAYMENT

Should any incorporated text from the Standard Specifications for Road and Bridge Construction (SSRBC) below conflict with this Contract's GENERAL TERMS & CONDITIONS, said GENERAL TERMS & CONDITIONS shall govern. The following text in PAY ITEMS / SCHEDULE OF PRICES shall also revise and amend the various "Method of Measurement" and "Basis of Payment" sub-sections normally included in the technical portion of the SSRBC:

- 1.1 SECTION 109.01 MEASUREMENT OF QUANTITIES [INCORPORATED IN FULL]
- 1.2 SECTION 109.02 SCOPE OF PAYMENT [INCORPORATED IN FULL]
- 1.3 SECTION 109.03 INCREASED OR DECREASED QUANTITIES [INCORPORATED IN FULL]
- 1.4 SECTION 109.04 PAYMENT FOR EXTRA WORK [INCORPORATED IN FULL]
- 1.5 SECTION 109.05 EXPENSES INCURRED BY THE DEPARTMENT [NOT INCLUDED]
- 1.6 SECTION 109.06 PAYMENT FOR ITEMS OMITTED WHEN PARTIALLY COMPLETED [INCORPORATED IN FULL]
- 1.7 ~~SECTION 109.07 PARTIAL PAYMENTS~~ [SEE III GENERAL TERMS & CONDITIONS]
- 1.8 SECTION 109.08 ACCEPTANCE AND FINAL PAYMENT [INCORPORATED IN FULL]
- 1.9 SECTION 109.09 CONTRACT CLAIMS [INCORPORATED IN FULL]
- 1.10 SECTION 109.10 CONTRACTOR RECORD RETENTION [NOT INCLUDED]
- 1.11 ~~SECTION 109.11 PAYMENTS TO SUBCONTRACTORS~~ [SEE III GENERAL TERMS & CONDITIONS]
- 1.12 SECTION 109.12 SUBCONTRACTOR MOBILIZATION PAYMENTS [NOT INCLUDED]

### 2. PAY ITEMS / SCHEDULE OF PRICES

Pay items for the work of this contract are listed in IV SCHEDULE OF PRICES. Contract payments for said items will be made as herein described.

All costs for items of work, which are not specifically mentioned to be included in a particular lump sum or unit price payment item, are included in the listed item most closely associated with the work involved.

#### 2.1 MOBILIZATION

##### 2.1.1 PAYMENT

Payment will be made for costs associated with mobilization as defined by SSRBC 671, access and staging as defined by VII.1 ACCESS AND STAGING AREAS, and with providing, installing, maintaining and removing temporary traffic control and protection, as defined by SSRBC 701 and VII.3 WORK ZONE TRAFFIC CONTROL AND PROTECTION.

##### 2.1.2 METHOD OF MEASUREMENT

This Work will not be measured.

##### 2.1.3 UNIT OF MEASURE

Unit of Measure: LUMP SUM (LS)

---



## 2.2 PREPARATION OF BASE

### 2.2.1 PAYMENT

Payment will be made for costs associated with preparing the existing aggregate base as defined by SSRBC 358 and modified by VII.2 REPAIR AND PREPARATION OF BASE COURSE.

### 2.2.2 METHOD OF MEASUREMENT

This Work will not be measured.

### 2.2.3 UNIT OF MEASURE

Unit of Measure: LUMP SUM (LS)

## 2.3 AGGREGATE BASE REPAIR

### 2.3.1 PAYMENT

Per SSRBC 358.07.

### 2.3.2 METHOD OF MEASUREMENT

Per SSRBC 358.06.

### 2.3.3 UNIT OF MEASURE

Unit of Measure: TON (TON)

## 2.4 BITUMINOUS MATERIALS (PRIME COAT)

### 2.4.1 PAYMENT

Per SSRBC 406.

### 2.4.2 METHOD OF MEASUREMENT

Per SSRBC 406.

### 2.4.3 UNIT OF MEASURE

Unit of Measure: POUND (LB)

## 2.5 HMA SURFACE COURSE, 3 INCHES

### 2.5.1 PAYMENT

Per SSRBC 406.

### 2.5.2 METHOD OF MEASUREMENT

Per SSRBC 406.

### 2.5.3 UNIT OF MEASURE

Unit of Measure: TON (TON)

## VI. STANDARD SPECIFICATIONS

The following Standard Specifications are those that are technical in nature intended to govern the Work and are hereby incorporated by reference to these Contract Documents. These Standard Specifications incorporated by reference shall serve to govern the Work as if they were otherwise included in full. Excluded sections may be explicitly shown and struck-thru for the purposes of clarification and, when applicable, underlined when that particular sub-section is revised or amended by the Special Provisions.

### 1. STANDARD SPECIFICATIONS FOR ROAD AND BRIDGE CONSTRUCTION, ADOPTED APRIL 1, 2016, INCLUDING ALL SUPPLEMENTAL SPECIFICATIONS ADOPTED UP THRU AND TO JANUARY 1, 2021 (SSRBC)

Any and all references to “Department” and “Engineer” shall be construed to mean the Village of Carol Stream (“Village”) instead.

#### 1.1 SECTION 358. REPAIR AND PREPARATION OF BASE COURSE

358.01 DESCRIPTION

358.02 MATERIALS

358.03 EQUIPMENT

358.04 AGGREGATE BASES [SEE SPECIAL PROVISION]

~~358.05 OLD BITUMINOUS, BRICK, AND CONCRETE [NOT INCLUDED]~~

358.06 METHOD OF MEASUREMENT [SEE V.2 PAY ITEMS / SCHEDULE OF PRICES]

358.07 BASIS OF PAYMENT [SEE V.2 PAY ITEMS / SCHEDULE OF PRICES]

#### 1.2 SECTION 406. HOT-MIX ASPHALT BINDER AND SURFACE COURSE

406.01 DESCRIPTION

406.02 MATERIALS

406.03 EQUIPMENT

~~406.04 KEEPING ROAD OPEN TO TRAFFIC [NOT INCLUDED]~~

406.05 PREPARING, PRIME COAT FOR AGGREGATE BASES, AND TACK COAT OR FULL LANE SEALANT

406.06 PLACING

406.07 COMPACTION

~~406.08 BUTT JOINTS [NOT INCLUDED]~~

~~406.09 APPROACHES, INTERSECTIONS, AND ENTRANCES [NOT INCLUDED]~~

~~406.10 MULTI-LANE PAVEMENT RESURFACING [NOT INCLUDED]~~

~~406.11 SURFACE TESTS [NOT INCLUDED]~~

406.12 PROTECTION OF PAVEMENT

406.13 METHOD OF MEASUREMENT [SEE V.2 PAY ITEMS / SCHEDULE OF PRICES]

406.14 BASIS OF PAYMENT [SEE V.2 PAY ITEMS / SCHEDULE OF PRICES]

#### 1.3 SECTION 671. MOBILIZATION

671.01 DESCRIPTION

~~671.02 BASIS OF PAYMENT [SEE V.2 PAY ITEMS / SCHEDULE OF PRICES]~~

---

#### 1.4 SECTION 701. WORK ZONE TRAFFIC CONTROL AND PROTECTION

701.01 DESCRIPTION

701.02 MATERIALS

701.03 EQUIPMENT

701.04 GENERAL [SEE SPECIAL PROVISION]

~~701.05 MAXIMUM LENGTH OF LANE CLOSURE [NOT INCLUDED]~~

~~701.06 MINIMUM LANE WIDTH [NOT INCLUDED]~~

~~701.07 DROP-OFFS [NOT INCLUDED]~~

701.08 CONTRACTOR'S OPERATIONS AND EQUIPMENT [SEE SPECIAL PROVISION]

~~701.09 USE OF MEDIAN CROSSOVERS [NOT INCLUDED]~~

701.10 SURVEILLANCE

701.11 EQUIPMENT PARKING AND STORAGE [SEE SPECIAL PROVISION]

701.12 PERSONAL PROTECTIVE EQUIPMENT

701.13 FLAGGERS [SEE SPECIAL PROVISION]

701.14 SIGNS

701.15 TRAFFIC CONTROL DEVICES

701.16 LIGHTS

~~701.17 SPECIFIC CONSTRUCTION OPERATIONS [NOT INCLUDED]~~

~~701.18 HIGHWAY STANDARDS APPLICATION [NOT INCLUDED]~~

~~701.19 METHOD OF MEASUREMENT [SEE V.2 PAY ITEMS / SCHEDULE OF PRICES]~~

~~701.20 BASIS OF PAYMENT [SEE V.2 PAY ITEMS / SCHEDULE OF PRICES]~~

#### 1.5 HIGHWAY STANDARDS (REVISION #223)

The Contractor shall adhere to any highway standard that is applicable to the Work specified herein and in the case of conflict between a highway standard and the Special Provisions, the Special Provisions shall govern.

## 2. ILLINOIS URBAN MANUAL, LATEST EDITION

As it relates to **Error! Reference source not found. Error! Reference source not found.**, this Work shall be governed by the latest edition of the Illinois Urban Manual as of the issuing date of this Invitation for Bids, as well as any updates, revisions or amendments that may occur after the execution of the Contract and during execution of the Work, up to and including final acceptance. The Practice Standards, Construction Specifications, Material Specifications and Standard Drawings shall apply unless superseded by the Plans or the Special Provisions contained herein. The manual is available at the website <https://illinoisurbanmanual.org>.

**\*\*\* END OF STANDARD SPECIFICATIONS \*\*\***

## VII. SPECIAL PROVISIONS

The following Special Provisions included herein shall amend, void, supersede, or supplement the Standard Specifications as detailed herein.

Where any section, subsection, paragraph, or subparagraph of the Standard Specifications is amended, voided, or superseded by any of the following paragraphs, any provision of such section, subsection, paragraph, or subparagraph standing unaffected, shall remain in effect. The Special Provisions shall govern in lieu of any particular provision of the Standard Specifications so amended, voided, or superseded, and not in addition to the portion changed.

Where any section, subsection, paragraph, or subparagraph of the Standard Specifications is supplemented by any of the following paragraphs, the provisions of such section, subsection, paragraph, or subparagraph shall remain in effect. The Special Provisions shall govern in addition to the particular Standard Specifications so supplemented, and not in lieu thereof.

### 1. ACCESS AND STAGING AREAS

#### 1.1 DESCRIPTION

The Work will occur entirely upon either the Carol Stream Park District's property or within the Village's property or easements. The Carol Stream Park District authorizes the Contractor temporary access to the property(s) commonly known as Memorial Park for the purposes of constructing the Work. Obtaining temporary easements through residential properties is discouraged and will be the responsibility of the successful Bidder.

#### 1.2 HAUL ROUTES

The movement of construction equipment and trucking shall occur as much as practical upon the Village-owned streets. There are four main points of access: (1) between Kuhn Road and the Water Reclamation Center's entrance; (2) the bridge between 270-290 Arrowhead Trail; (3) Bennett Drive; and (4) Memorial Park (east end only). The bridge is capable of carrying construction traffic. In general, access through the Water Reclamation Center is restricted, but may be granted on a case-by-case basis.

#### 1.3 STAGING AREAS

The main staging area will be along the access drive (McNees Drive) to the Water Reclamation Center as shown on the plans. The Carol Stream Park District will allow for staging and storing of equipment and materials only on the east end of Memorial Park.

The staging and storing of equipment and materials is prohibited on all Village-owned streets.

### 2. REPAIR AND PREPARATION OF BASE COURSE

SSRBC 358 REPAIR AND PREPARATION OF BASE shall be incorporated in full except for the changes noted by the following:

#### 2.1 SECTION 358.01 AGGREGATE BASES

Revise only the applicable test as follows; all other requirements remain unchanged:

---

(b) Preparation. After the repairs have been made in the base course, any area having ruts, depressions, corrugations, excessive crown, or loose material shall be brought to a smooth grade and proper crown by repeatedly wetting with water applied by means of a sprinkler, blading with a road grader or multiple blade maintainer, and rolling with a pneumatic tired roller. The base course shall be bladed lightly to such a depth that sufficient material will be obtained to true up the surface of the base course. During the smoothing operations, the roadbed from the edges of the base to the shoulder lines shall be bladed to a smooth uniform slope so that the surface will drain and not impound water.

~~After the surface of the base course has been brought to a smooth grade and proper crown, it shall be compacted by repeated wetting and rolling with a pneumatic tired roller for a period of not less than two days. During this time, the surface shall be kept in a damp condition. Before a prime coat is applied, the base shall be surface dry, but at not time shall the period of drying be less than 24 hours. When required by the Engineer, the base course shall be swept with a mechanical sweeper or hand brooms before a prime coat is applied. The sweeping shall be continued until all dust, mud and foreign material are removed. Traffic shall not be allowed upon the prepared base course after the final sprinkling, or, if a bituminous prime coat has been applied, until the Engineer has approved the penetration of the prime coat.~~

### 3. WORK ZONE TRAFFIC CONTROL AND PROTECTION

SSRBC 701 WORK ZONE TRAFFIC CONTROL AND PROTECTION shall be incorporated in full except for the changes noted by the following:

#### 3.1 SECTION 701.04 GENERAL

Revise only the applicable text as follows; all other requirements remain unchanged:

~~Work zone traffic control and protection shall be according to the traffic control plan and the MUTCD. The work zone signs and traffic control devices shall meet the Department's quality standards as shown in the "Traffic Control Field Manual".~~

~~The traffic control shown on the plans represents the minimum required combination of traffic control devices needed for a particular construction operation. Conditions created by the Contractor's operation which are not covered by the plans shall be delineated by devices as directed by the Engineer at no additional cost to the Department. Revisions or modifications of the traffic control shall have the Engineer's written approval.~~

The work zone as shown on the Plans is approximate and shall be based on maintaining two-way traffic at all times. The Contractor shall be responsible for the work zone traffic control and protection based on the conditions created by the Contractor's operations, but shall generally conform with Highway Standard 701611-01 URBAN HALF ROAD CLOSURE, MULTILANE, 2W WITH MOUNTABLE MEDIAN. The work zone traffic control and protection shall be according to the MUTCD and the devices shall meet the Illinois Department of Transportation's quality standards as shown in the "Traffic Control Field Manual". If deemed insufficient to safeguard the motoring public, the Village may direct the Contractor to provide additional devices at no additional cost to the Village.

#### 3.2 SECTION 701.08 CONTRACTOR'S OPERATIONS AND EQUIPMENT

Revise only the applicable text as follows; all other requirements remain unchanged.

The Contractor shall keep all equipment, material, and vehicles ~~off the pavement and shoulders on the side of the pavement which is open to traffic~~ outside of traffic and within areas delineated by traffic control devices to the satisfaction of the Village.

### 3.3 SECTION 701.11 EQUIPMENT PARKING AND STORAGE

Replace this section in its entirety with the following:

During working hours, all vehicles and/or non-operating equipment shall be parked outside of traffic and within areas delineated by traffic control devices to the satisfaction of the Village. When not being utilized to inform and direct traffic, sign trailers, arrow boards, and portable changeable message boards shall be treated as non-operating equipment.

### 3.4 SECTION 701.13 FLAGGERS

Revise only the applicable text as follows; all other requirements remain unchanged.

~~All flaggers shall be certified by an agency approved by the Department. While on the job site, each flagger shall have in his/her possession a current driver's license and a current flagger certification I.D. meeting Department requirements. For non drivers, the Illinois Identification Card issued by the Secretary of State will meet the requirement for a current driver's license. This flagger certification requirement may be waived by the Engineer for emergency situations that arise due to actions beyond the Contractor's control where flagging is needed to maintain safe traffic control on a temporary basis. A flagger shall be required whenever two-way traffic cannot be maintained and the drivers of opposing traffic cannot visually coordinate between themselves across the work zone. Additional flaggers are required if a single flagger cannot visually coordinate with the drivers of opposing traffic from a location that is outside of traffic. Flaggers need not be certified, but they cannot be assigned other duties that, in the opinion of the Village, inhibits their ability to perform this function safely and effectively.~~

## VIII. PLANS AND DOCUMENTS

1. "KLEIN CREEK TRAIL – KUHN ROAD TO THUNDERBIRD TRAIL & BENNETT DRIVE"

# KLEIN CREEK TRAIL PROJECT

## KUHN ROAD TO THUNDERBIRD TRAIL & BENNETT DRIVE

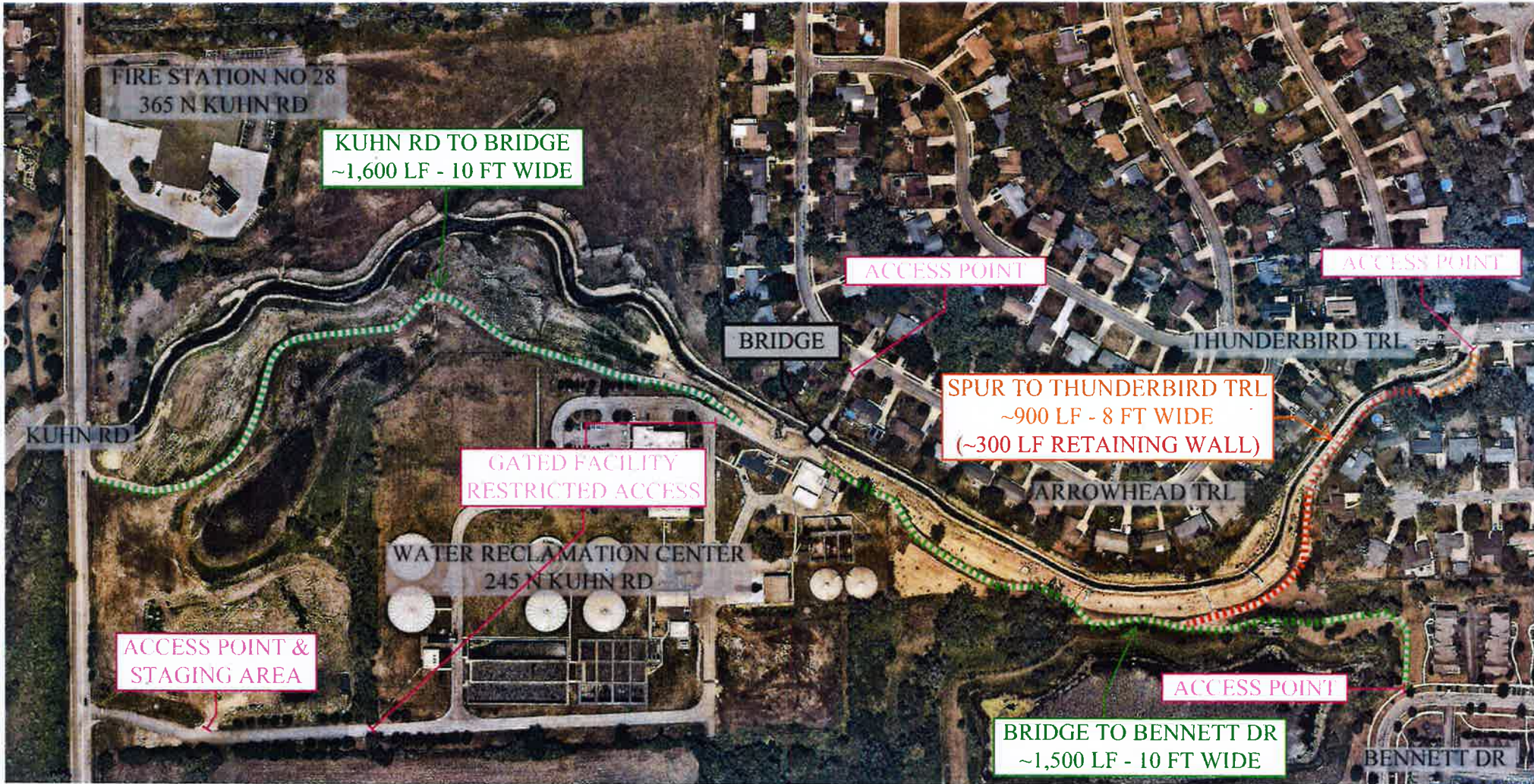

1.5% MAXIMUM CROSS SLOPE



HMA SURFACE COURSE, PG64-22, IL-9.5L, MIX. "C", N30 - 3" (SINGLE LIFT)  
PRIME COAT  
EXISTING CRUSHED AGGREGATE BASE (CA-6)



## IX. BIDDER'S PROPOSAL FORM

(PLEASE TYPE OR PRINT THE FOLLOWING INFORMATION)

<b>Firm or Corporate Name</b>	Schroeder Asphalt Services, Inc.
<b>Main Business Address</b>	PO Box 831
<b>City, State, Zip Code</b>	Huntley, IL 60142
<b>Telephone Number</b>	815-923-4380
<b>Email Address</b>	Rachael@schroederasphalt.com
<b>Bidder's Contact Person</b>	Kyle Joustra

The undersigned certifies that they are:

<input type="checkbox"/> <b>The Owner / Sole Proprietor</b>	<input type="checkbox"/> <b>A Member of the Partnership</b>	<input checked="" type="checkbox"/> <b>An Officer of the Corporation</b>	<input type="checkbox"/> <b>A Member of the Joint Venture</b>
-----------------------------------------------------------------	-----------------------------------------------------------------	------------------------------------------------------------------------------	-------------------------------------------------------------------

Herein after called the Bidder and that the members of the Partnership or Officers of the Corporation are as follows:

(PLEASE TYPE OR PRINT THE FOLLOWING INFORMATION)

Ronald Schroeder, President  
(President or Partner)

Jennifer Graves, Vice President  
(Vice-President of Partner)

Jennifer Griebel, Corporate Secretary  
(Secretary of Partner)

Ronald Schroeder, Treasurer  
(Treasurer or Partner)

Further, the undersigned declares that the only person or parties interested in this bid as principals are those named herein; that this bid is made without collusion with any other person, firm or corporation; that they have fully examined the proposed forms of agreement and the contract specifications for the above designated purchase, all of which are on file at the Department of Engineering Services, Carol Stream, Illinois, and all other documents referred to or mentioned in the contract documents, specifications and attached exhibits, including

Addenda No. N/A thru \_\_\_\_\_ issued thereto;

Further, the undersigned proposes and agrees, if this bid is accepted, to provide all necessary machinery, tools, apparatus and other means of construction, including transportation services necessary to furnish all the materials and equipment specified or referred to in the contract documents in the manner and time therein prescribed.

Further, the undersigned certifies and warrants that they are duly authorized to execute this

certification / affidavit on behalf of the Bidder and in accordance with the Partnership Agreement or by-laws of the Corporation, and the laws of the State of Illinois and that this Certification is binding upon the Bidder and is true and accurate.

Further, the undersigned certifies that they have examined and carefully prepared this bid and has checked the same in detail before submitting this bid, and that the statements contained herein are true and correct.

If a Corporation, the undersigned further certifies that the recitals and resolutions attached hereto and made a part hereof were properly adopted by the Board of Directors of the Corporation at a meeting of said Board of Directors duly called and held and have not been repealed, nor modified and that the same remain in full force and effect. (Bidder may be requested to provide a copy of the corporate resolution granting the individual executing the contract documents authority to do so.)

Further, the Bidder certifies that they have provided equipment, supplies or services comparable to the items specified in this contract to the parties listed in the reference section below and authorizes the Village to verify references of business and credit at its option.

Bid Submittal Checklist *	
N/A	SCHEDULE OF PRICES (via QuestCDN VirtuBid™/vBid™ only)
✓	BIDDER'S PROPOSAL FORM (this form)
✓	GOVERNMENTAL CONTRACT COMPLIANCE CERTIFICATIONS
✓	PRE-QUALIFICATION & REFERENCES
*Fully-executed versions of all checklist items above must be provided in order for the Bidder to be considered responsive.	

Ronald Schroeder  
 \_\_\_\_\_  
 (Printed Name)

President



*Ronald Schroeder*  
 \_\_\_\_\_  
 (Signature)

Corporate Seal

Subscribed and Sworn to before me this 2nd day of August

*Rachael McDow*  
 \_\_\_\_\_

Rachael McDow

11/04/2026

(Notary Public)

(Commission Expiration Date)

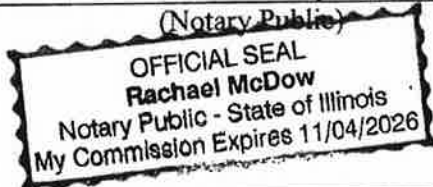

## X. GOVERNMENTAL CONTRACT COMPLIANCE CERTIFICATIONS

I, Ronald Schroeder (name), certify that I am employed as the President (title) of Schroeder Asphalt Services, Inc. (company), a contractor/subcontractor for the work described in the Agreement to which this certificate is attached, and I hereby certify that I am authorized to make this certificate and that I have personal knowledge of the matters certified to herein, and that following certifications are true and correct:

1. Certification under 720 ILCS 5/33E-11

The Company is not barred from contracting with any unit of state or local government as a result of a violation of either Section 33E-3 or 33E-4 of Article 33E of the Illinois Criminal Code of 1961 or any similar offense of any State of the United States which contains the same elements as the Illinois offenses of bid-rigging or bid rotating.

2. Payments to Illinois Department of Revenue

The Company is not delinquent in payment of any taxes to Illinois Department of Revenue – 65 ILCS 5/11-42.1

3. Substance Abuse Prevention on Public Works

The Company has in place a written program which meets or exceeds the program requirements of the Substance Abuse Prevention on Public Works Projects Act (Public Act 95-0635), and will provide a copy thereof to the Village of Carpentersville prior to commencement of the work on the Project.

4. Illinois Public Works Employment Discrimination Act

The Contract shall be performed in compliance with all requirements of the Illinois Public Works Employment Discrimination Act, 775 ILCS 10/0.01

5. Certified Payroll – Prevailing Wage Act - 820 ILCS 130/5

The Company shall pay not less than the prevailing hourly rate of wages, and the generally prevailing rate of hourly wages for legal holiday and overtime work, as determined by the Illinois Department of Labor and the Village of Carol Stream to all laborers, workers, and mechanics performing work under this Contract. All bonds provided by the Company under the terms of this contract shall include such provisions as will guarantee the faithful performance of the Company's obligations under this clause and under the Prevailing Wage Act, 820 ILCS 130/1 et. seq. Should the Department of Labor revise any prevailing rate of hourly wages, such revised rate shall be applicable to this Contract; however, in no event shall the increase in any prevailing rate of hourly wages be a basis for a change order or other claim for an increase in the Contract Sum. The Company and each of its subcontractors participating on the Project shall make and keep those records required under Section 5 of the Prevailing Wage Act. The Company and any of its subcontractors shall submit a monthly certified payroll statement to verify the payment of prevailing wages as required under the Prevailing Wage

Act.

6. Non-Discrimination: EEOC

The Company is an "equal opportunity employer" as defined by Section 2002(e) of Chapter 21, Title 42, U.S. Code Annotated and Executive Orders #11246 and #11375 (42 U.S.C., Section 2002(e)); Executive Order No. 11246, 30 F.R. 12319 (1965); Executive Order No. 11375, 32 F.R. 14303 (1967) which are incorporated herein by reference. The Equal Opportunity Clause, Section 6.1 of the Rules and Regulations of the Department of Human Rights of the State of Illinois is a material part of any contract awarded on the basis of this proposal. The Company shall not discriminate on the basis of race, color, sex, national origin, religion, ancestry, age, marital status, physical or mental handicap or unfavorable discharge for military service.

7. Human Rights Act

The Company shall perform the Contract in compliance with all requirements of the Illinois Human Rights Act, 775 ILCS 5/1-101 et seq., and that the Company and its subcontractors shall not engage in any prohibited form of discrimination in employment as defined in the Act. The Company shall maintain, and require that its subcontractors maintain, policies of equal employment opportunity which shall prohibit discrimination against any employee or applicant for employment on the basis of race, religion, color, sex, national origin, ancestry, citizenship status, age, marital status, physical or mental disability unrelated to the individual's ability to perform the essential functions of the job, association with a person with a disability, or unfavorable discharge from military service. The Company and all subcontractors shall place appropriate statements identifying their companies as equal opportunity employers in all advertisements for workers to be employed in work to be performed under this contract.

8. Sexual Harassment Policy

Pursuant to Section 2-105 (A)(4) of the Illinois Human Rights Act, the Company and each subcontractor has adopted and maintains written sexual harassment policies that shall include, at a minimum, the following information:

- a. the illegality of sexual harassment;
- b. the definition of sexual harassment under State law;
- c. a description of sexual harassment, utilizing examples;
- d. the Company's/subcontractor's internal complaint process, including penalties;
- e. the legal recourse, investigative and complaint process available through the Department and Commission;
- f. directions on how to contact the Department and the Commission; and
- g. protection against retaliation as provided by Section 6-101 of the Illinois Human Rights Act.

A copy of these policies shall be provided to the Owner or Consultant on request

---

9. Drug Free Workplace Act

The Company shall comply with all provisions of the Drug Free Workplace Act, 30 ILCS 580/1 et seq.

10. Compliance with Governmental Regulations

The Company and any subcontractors shall comply with and perform all Work required under the Contract Documents in conformance with all applicable federal, state and local laws, regulations and/or ordinances.

Ronald Schroeder  
\_\_\_\_\_  
(Printed Name)

President  
\_\_\_\_\_  
(Printed Title)

  
\_\_\_\_\_  
(Signature)

Corporate Seal



Subscribed and Sworn to before me this 2nd day of August

  
\_\_\_\_\_  
(Notary Public)

11/04/2026  
\_\_\_\_\_  
(Commission Expiration Date)

## XI. PRE-QUALIFICATION & REFERENCES

### 1. PRE-QUALIFICATION

As allowed by sub-section §5-8-4 of the Code of Ordinances of the Village of Carol Stream, the Village will conduct a pre-qualification procedure in accordance with Section 102.01(b) of the Standard Specifications for Road and Bridge Construction.

Prospective Bidders must be on the electronic planholders list before said Bidder may access the electronic bidding module (i.e. QuestCDN's VirtuBid™/vBid™). In order to be allowed access to the electronic bidding module, all prospective Bidders shall email a scanned copy of their Certificate of Eligibility provided by the Illinois Department of Transportation to [engineering@carolstream.org](mailto:engineering@carolstream.org). It is requested that the subject line of the email include a reference to the specific project (e.g. "KLEIN CREEK TRAIL – COE FOR [CONTRACTOR]").

Each bidder must possess a Certificate of Eligibility provided by the Illinois Department of Transportation in at least one of the following classes:

003 – HMA Plant Mix

005 – HMA Paving. (IDOT tonnage restrictions do not apply to this contract.)

Said access to the electronic bidding module will not supersede the process in establishing the "lowest responsible bidder" as set forth in sub-section §5-8-6 of the Code of Ordinances of the Village of Carol Stream. Therefore, the Village will retain its right to reject a successful Bidder on the basis of DISQUALIFICATION OF BIDDERS after the PUBLIC OPENING OF BIDS in accordance with the procedure as set forth in CONSIDERATION OF BIDS.

### 2. REFERENCES

Bidders shall provide at least four references, at least one of which shall be a local municipality or local government agency, for the Village to review its past performance on projects that demonstrate their firm's ability to perform work of similar size and scope.

The substantial completion date must be within the last five years from the date of this solicitation.

The information must include a brief description of the scope of work only as it pertains to the Bidder's self-performance and whether the Bidder served as the prime or as a sub-contractor.

Bidders may use either the attached Reference Form or use their own form so long as the requested information is provided.

References shall also be provided for any sub-contractor that will self-perform the majority of Work for any contract line item on the SCHEDULE OF PRICES, the total value of which exceeds 25% of the Total Base Bid Price.

**REFERENCES FORM**

Project Name & Location	*Please see attached References	
Self-Performed Work Description		
Prime (Y/N)?		Substantial Completion Date (MM/YY)
Owner or Responsible Agency		
Point-of-Contact Name & Phone		
Project Name & Location		
Self-Performed Work Description		
Prime (Y/N)?		Substantial Completion Date (MM/YY)
Owner or Responsible Agency		
Point-of-Contact Name & Phone		
Project Name & Location		
Self-Performed Work Description		
Prime (Y/N)?		Substantial Completion Date (MM/YY)
Owner or Responsible Agency		
Point-of-Contact Name & Phone		
Project Name & Location		
Self-Performed Work Description		
Prime (Y/N)?		Substantial Completion Date (MM/YY)
Owner or Responsible Agency		
Point-of-Contact Name & Phone		

# FOREST PRESERVE & PARK DISTRICTS

## 2017 JOBS

JOB NO	PROJECT	ENGINEER/OWNER	CITY / VILLAGE	CONTACT	PHONE NO.
217032	Grolich Park	Elanar Const / Centre of Elgin	Elgin	Erick W Oleson	773/628-7011
217033	Madison Meadow Recreation Center	Corp Constr Svcs/Lombard Park D	Lombard	Michael Rink	630/271-0500
217050	Blackwell Fleet Management Building	Frontier Const / DuPage County F	Wheaton	Jon Healy	708/675-4334
217063	Parkside Preschool Water Main Replacement	Mauro / Palatine Park District	Palatine	Carmi Lullo	847/878-5078
217071	Kane County Maintenance Building	Carmichael / Kane County FP	Elburn	Jim Carmichael	815/568-8337
217072	Bruce Ream Park Improvements	openhaver / Hampshire Park Di	Hampshire	Laura Frillman	847/428-6696 X112

## 2018 JOBS

JOB NO	PROJECT	ENGINEER/OWNER	CITY / VILLAGE	CONTACT	PHONE NO.
218060	Asphalt Resurfacing of Prairie Trail Link & Maint Shop Parking Lot	McHenry County Conservation	McHenry	Perry Weborg	815/338-6223

## 2019 JOBS

JOB NO	PROJECT	ENGINEER/OWNER	CITY / VILLAGE	CONTACT	PHONE NO.
219026	Itasca Recreation & Fitness Center Proposed Site Improvements	Itasca Park District	Itasca		
219057	Paving at the Tomo Chi-Chi Knolls	Kane County Forest Preserve	Gilbert's	Anna Marano	630/208-2006
219058	2019 Sidewalk Program, Phase 1(Contract DPW-1912	DiNatale/Palatine Pk Dist	Palatine	Mike DiNatale	630/514-3118

## 2020 JOBS

JOB NO	PROJECT	ENGINEER/OWNER	CITY / VILLAGE	CONTACT	PHONE NO.
218060	Asphalt Resurfacing of Prairie Trail Link & Maint Shop Parking Lot	McHenry County Conservation	McHenry	Perry Weborg	815/338-6223
220028	Millennium Trail - McDonald Woods FP	Lake County Forest Preserve	Lindenhurst	Lisa Roberts	847/968-3210
220066	Asphalt Repair at Timber Ridge, Kline Creek Farm Forest Preserve (Project #GM-20-04)	Forest Preserve of DuPage County	West Chicago	Mike Wiseman	630/876-5925
220093	2020 MFT Maintenance Program	Village of Island lake	Island Lake	Mark Rooney	847/526-8764
220102	Sullivan Center Asphalt 2020	Vernon Hills Park Dist	Vernon Hills	James Kim	224/406-7818

## 2021 JOBS

JOB NO	PROJECT	ENGINEER/OWNER	CITY / VILLAGE	CONTACT	PHONE NO.
221022	Asphalt Maintenance Service	DuPage County Forest Preserve		Mike Wiseman	630/876-5925
221041	DuPage River Trail-Riverview Farmstead Imp	Will County FP			815-727-8700
221061	Ballfield Quad Paving - Four Season Pk Bid #1074	Plainfield Park District	Plainfield	Bob Collins	815/436-8812
221073	2021 Street Reconstruction Program	Salt Creek Rural Park District	Rolling Meadows	Ryan Lindeman	847/343-2963

## 2022 JOBS

JOB NO	PROJECT	ENGINEER/OWNER	CITY / VILLAGE	CONTACT	PHONE NO.
222026	Jaycee Park Tennis & Basketball Ct Replace	Park Ridge Park Dist	Park Ridge	Jennifer Menunier	847/292-1258
222061	Eaton Trail Resurfacing	Plainfield Park District	Plainfield	Bob Collins	815-436-8812
222068	Fox River Trail Resurfacing	Kane County Forest Preserve Dist	Elgin	Anna Marano	630-208-2006
222101	Path in Huntley	VO Huntley / Huntley Park Dist	Huntley	Tim Farrell	847-515-5285
222121	NRC Masonry Sealing & Repair Project	Norridge Park District	Norridge	Jerry Hernandez	708-457-1244
222130	Ellis, Harts, Sports Center & Sutton	Round Lake Park Dist	Round Lake	Ana Olivares	847-546-8558
222136	Fox River Trail Paths	City of Elgin	Elgin	Greg Hulke	847-931-6001



**PUBLIC WORKS CONSTRUCTION CONTRACT  
VILLAGE OF CAROL STREAM**

---

**THIS CONTRACT** ("Contract") is made and entered into by and between the **VILLAGE OF CAROL STREAM**, an Illinois municipal corporation and home rule unit of government, (hereinafter referred to as the "Village") and **SCHROEDER ASPHALT SERVICES, INC.** hereinafter to as (the "Contractor") and its successors.

**IN CONSIDERATION OF** the recitals and the mutual covenants and agreements set forth in this Contract, the sufficiency of which is hereby acknowledged, the parties agree as follows:

1. This contract shall embrace and include all of the Contract Documents listed below and shall be incorporated herein by reference:
    - a. Cover Sheet – Invitation for Bid
    - b. Table of Contents
    - c. Legal Notice – Invitation to Bid
    - d. Instructions to Bidders
    - e. General Terms and Conditions
    - f. Schedule of Prices (accepted by the Village)
    - g. Price and Payment Procedures
    - h. Standard Specifications
    - i. Special Provisions
    - j. Plans and Documents
    - k. Bidder's Proposal Form (accepted by the Village)
    - l. Governmental Contract Compliance Certifications
    - m. References
    - n. This Contract
    - o. Labor and Material Bond
    - p. Performance Bond
    - q. Certificate(s) of Insurance
    - r. Addenda (If applicable)
-

**XII. FORM OF CONTRACT**

**1. VILLAGE OF CAROL STREAM'S FORM OF CONTRACT**

COVER SHEET

---

2. The Village agrees to pay, and the Contractor agrees to accept as full payment for the items, and installation of the same, which are the subject matter of this contract the total sum of \$99,825.00, per Contract Document (f) Schedule of Prices, paid in accordance with the provisions of the Local Government Prompt Payment Act.
  3. The Contractor represents and warrants that it will comply will all applicable Federal, State and local laws concerning prevailing wage rates and all Federal, State and local laws concerning equal employment opportunities.
  4. The Contractor shall commence work under this Contract upon written Notice to Proceed from the Village and shall complete work on this project per the dates provided in Contract Document (e) General Terms and Conditions, sub-section 3.2. Time is of the essence of this Contract and Contractor agrees to achieve completion within the contract time by all proper and appropriate means including working overtime without additional compensation.
  5. Bonds required to guarantee performance and payment for labor and material for this work shall be in a form acceptable to the Village and shall provide that they shall not terminate on completion of the work, but shall be reduced to ten percent (10%) of the contract sum upon the date of final payment by the Village for a period of one (1) year to cover a warranty and maintenance period, which Contractor agrees shall apply to all material and workmanship for one (1) year from the date of issuance of the final payment by the Village.
  6. Pursuant to the provisions of Section 5 of the Mechanics' Lien Act of Illinois, prior to making any payment on this contract the Village demands that the Contractor furnish a written statement of the names of all parties furnishing labor and/or materials under this Contract and the amounts due or to become due on each. This statement must be made under oath or be verified by affidavit. Final payment shall not be issued by the Village nor shall any retained percentage become due until releases and waivers of lien have been supplied as the Village designates.
  7. In executing this Contract, Contractor agrees that it has examined the site of the work and the conditions existing therein, has examined the Contract Documents and taken and compared field measurements and conditions with those Documents.
  8. This Contract and the Contract Documents represent the entire Agreement between the parties and may not be modified without the written approval of both parties.
-

IN WITNESS WHEREOF, the Contractor has hereunto set their hands this \_\_\_\_\_ day of \_\_\_\_\_, 20\_\_\_\_.

\_\_\_\_\_  
(Printed Name)

\_\_\_\_\_  
(Printed Title)

\_\_\_\_\_  
(Signature)

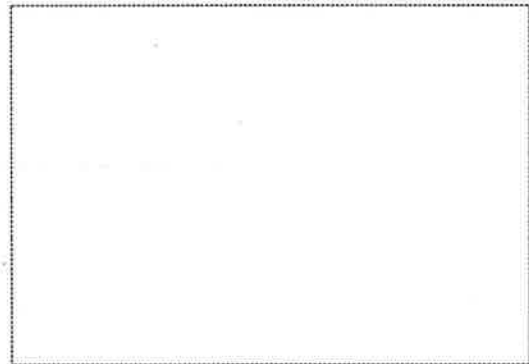

(Corporate Seal)

NOTARY PUBLIC – STATE OF ILLINOIS

Subscribed and Sworn to before me this \_\_\_\_\_ day of \_\_\_\_\_, 20\_\_\_\_

\_\_\_\_\_  
(Signature)

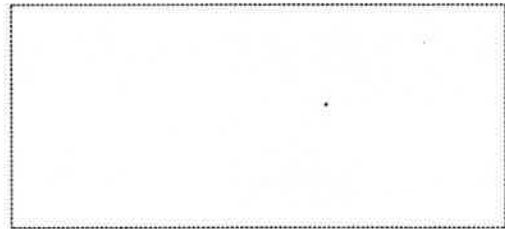

(Notary Seal)

THE VILLAGE OF CAROL STREAM, ILLINOIS

IN WITNESS WHEREOF, the Village has hereunto set their hands this \_\_\_\_\_ day of \_\_\_\_\_, 20\_\_\_\_.

By \_\_\_\_\_, Village Manager

\_\_\_\_\_

*Village of Carol Stream*  
Interdepartmental Memo

**TO:** Mayor and Trustees  
**FROM:** Robert Mellor, Village Manager *RM*  
**DATE:** July 26, 2023  
**RE:** Liquor License – 7-Eleven, 425 E. Geneva Road

---

7-Eleven Inc. d/b/a 7-Eleven #38850H located at 425 E. Geneva Road has a Class P liquor license and is applying for a Class PL liquor license. 7-Eleven #38850H currently sells packaged beer and wine and would like to sell all packaged alcohol. Attached for your consideration is an Ordinance decreasing their existing Class P liquor license and granting a Class PL liquor license to 7-Eleven Inc. d/b/a 7-Eleven #38850H, 425 E. Geneva Road.

A letter from 7-Eleven Inc. requesting change of their liquor license classification is attached for your review. Mayor Saverino as Local Liquor Commissioner is recommending issuance of this license.

Accordingly, staff recommends adoption of the attached Ordinance.

**ORDINANCE NO. 2023-08-\_\_\_\_\_**

**AN ORDINANCE AMENDING CHAPTER 11, ARTICLE 2 OF THE CAROL STREAM CODE OF ORDINANCES BY DECREASING THE NUMBER OF CLASS P LIQUOR LICENSES FROM 4 TO 3 (7-ELEVEN INC. d/b/a 7-ELEVEN #38850H, 425 E. GENEVA ROAD) AND INCREASING THE NUMBER OF CLASS PL LIQUOR LICENSES FROM 4 TO 5 (7-ELEVEN INC. d/b/a 7-ELEVEN #38850H, 425 E. GENEVA ROAD)**

BE IT ORDAINED BY THE MAYOR AND BOARD OF TRUSTEES OF THE VILLAGE OF CAROL STREAM, DUPAGE COUNTY, ILLINOIS, IN THE EXERCISE OF ITS HOME RULE POWERS, as follows:

SECTION 1: That Chapter 11, Article 2 of the Carol Stream Code of Ordinances, Classification of Liquor Licenses, be and the same is hereby amended by decreasing the number of Class P Liquor Licenses from four (4) to three (3).

SECTION 2: That Chapter 11, Article 2 of the Carol Stream Code of Ordinances, Classification of Liquor Licenses, be and the same is hereby amended by increasing the number of Class PL Liquor Licenses from four (4) to five (5).

SECTION 3: This Ordinance shall be in full force and effect from and after its passage and approval by law.

PASSED AND APPROVED THIS 7<sup>th</sup> DAY OF AUGUST, 2023.

AYES:

NAYS:

ABSENT:

\_\_\_\_\_  
Frank Saverino, Sr., Mayor

ATTEST:

\_\_\_\_\_  
Julia Schwarze, Village Clerk



7-ELEVEN, INC.

Village of Carol Stream  
500 N. Gary Ave.  
Carol Stream, IL 60188

Re: 7-Eleven #38850H  
425 E. Geneva Rd  
Carol Stream, IL 60188

I am writing this letter in regards the 7-Eleven above. This store currently holds a Class "P" license that allows the sale of packaged goods beer/wine. We are asking for your consideration to allow the store to hold a class "PL" license that would allow sales to include hard liquor.

Thank you in advance for your consideration of this change.

Sincerely,

*Susan Swanson* 7/20/2023

Susan Swanson | On Behalf of 7-Eleven, Inc.  
License Specialist

*Village of Carol Stream*  
**Interdepartmental Memo**

**TO:** Mayor and Trustees  
**FROM:** Robert Mellor, Village Manager *RMM*  
**DATE:** July 27, 2023  
**RE:** Liquor Licenses – Playoffs Bar & Grill, 720 E. North Avenue

---

Attached for your review and consideration are two Ordinances reducing the number of Class A and Class V Liquor Licenses by one. CDT Enterprise, Inc. d/b/a Playoffs Bar & Grill located at 720 E. North Avenue has closed. On May 1, 2023 this location was approved for a special use permit for an Adult Use Cannabis Dispensing Organization.

Staff recommends approval of the attached Ordinances reducing the Class A and Class V Liquor Licenses by one with regard to CDT Enterprise, Inc. d/b/a Playoffs Bar & Grill, 720 E. North Avenue.



**ORDINANCE NO. 2023-08-\_\_\_\_\_**

**AN ORDINANCE AMENDING CHAPTER 11, ARTICLE 2 OF THE  
CAROL STREAM CODE OF ORDINANCES BY DECREASING  
THE NUMBER OF CLASS A LIQUOR LICENSES FROM 17 TO 16  
(CDT ENTERPRISE, INC. d/b/a PLAYOFFS BAR & GRILL, 720 E. NORTH AVENUE)**

BE IT ORDAINED BY THE MAYOR AND BOARD OF TRUSTEES OF THE  
VILLAGE OF CAROL STREAM, DUPAGE COUNTY, ILLINOIS, IN THE EXERCISE OF  
ITS HOME RULE POWERS, as follows:

SECTION 1: That Chapter 11, Article 2 of the Carol Stream Code of Ordinances,  
Classification of Liquor Licenses, be and the same is hereby amended by decreasing  
the number of Class A Liquor Licenses from seventeen (17) to sixteen (16).

SECTION 2: This Ordinance shall be in full force and effect from and after its  
passage and approval by law.

PASSED AND APPROVED THIS 7<sup>th</sup> DAY OF AUGUST, 2023.

AYES:

NAYS:

ABSENT:

---

Frank Saverino, Sr., Mayor

ATTEST:

---

Julia Schwarze, Village Clerk

ORDINANCE NO. 2023-08-\_\_\_\_\_

**AN ORDINANCE AMENDING CHAPTER 11, ARTICLE 2 OF THE  
CAROL STREAM CODE OF ORDINANCES BY DECREASING  
THE NUMBER OF CLASS V LIQUOR LICENSES FROM 21 TO 20  
(CDT ENTERPRISE, INC. d/b/a PLAYOFFS BAR & GRILL, 720 E. NORTH AVENUE)**

BE IT ORDAINED BY THE MAYOR AND BOARD OF TRUSTEES OF THE  
VILLAGE OF CAROL STREAM, DUPAGE COUNTY, ILLINOIS, IN THE EXERCISE OF  
ITS HOME RULE POWERS, as follows:

SECTION 1: That Chapter 11, Article 2 of the Carol Stream Code of Ordinances,  
Classification of Liquor Licenses, be and the same is hereby amended by decreasing  
the number of Class V Liquor Licenses from twenty-one (21) to twenty (20).

SECTION 2: This Ordinance shall be in full force and effect from and after its  
passage and approval by law.

PASSED AND APPROVED THIS 7<sup>th</sup> DAY OF AUGUST, 2023.

AYES:

NAYS:

ABSENT:

\_\_\_\_\_  
Frank Saverino, Sr., Mayor

ATTEST:

\_\_\_\_\_  
Julia Schwarze, Village Clerk

**AN ORDINANCE APPROVING A SPECIAL USE PERMIT FOR AN AUTO REPAIR AND SERVICE FACILITY, AND A REAR YARD BUILDING SETBACK VARIATION (BARTEL'S AUTO CLINIC, 160 S. GARY AVENUE)**

**WHEREAS**, Tom Grotts, with E.P. Doyle & Son, on behalf of Bartel's Auto Clinic, hereinafter referred to as the Petitioner, has petitioned the Village of Carol Stream for a Special Use Permit for an Auto Repair and Service facility in accordance with Section 16-3-11 of the Unified Development Ordinance; and a Variation to reduce the required rear yard building setback, as provided in Section 16-3-9 of the Unified Development Ordinance, on the property legally described in Section 3 herein and commonly known as 160 S. Gary Avenue, Carol Stream, Illinois; and

**WHEREAS**, pursuant to Sections 16-8-4 (K) and 16-8-4 (L) of the Unified Development Ordinance, the Combined Plan Commission/Zoning Board of Appeals held a public hearing on the above petition on July 24, 2023 following proper legal notice of said public hearings, after which the Commission recommended to the Mayor and Board of Trustees of the Village that the Special Use Permit and Variation be approved; and

**WHEREAS**, the Combined Plan Commission/Zoning Board of Appeals has filed its Findings and Recommendations regarding the Special Use Permit and Variation with the Mayor and Board of Trustees, and the Mayor and Board of Trustees have duly considered said Findings and Recommendations.

**NOW, THEREFORE, BE IT ORDAINED BY THE MAYOR AND BOARD OF TRUSTEES OF THE VILLAGE OF CAROL STREAM, DU PAGE COUNTY, ILLINOIS, IN THE EXERCISE OF ITS HOME RULE POWERS, AS FOLLOWS:**

**SECTION 1:**

The Mayor and Board of Trustees of the Village of Carol Stream, after examining the Petition for the Special Use Permit, and the Findings and Recommendations of the Combined Plan Commission/Zoning Board of Appeals, have determined and find that the requested Special Use Permit:

1. Is deemed necessary for the public convenience at the location. *The new auto repair and service facility is necessary for public convenience because it will alleviate parking constraints and meet the growing needs of Bartel's Auto Clinic.*
2. Will not be unreasonably detrimental to or endanger the public health, safety, morals, comfort or general welfare. *The new auto repair and service facility will not in any way endanger the public health, safety, morals, comfort or general welfare.*
3. Will not be injurious to the use and enjoyment of other property in the immediate vicinity for the purposes already permitted, nor substantially diminish and impair property values within the neighborhood. *Other properties classified with the Industrial designation have received Special Use approval for auto repair and service facilities with no apparent injury to the use or enjoyment of properties in the immediate vicinity, or diminution or impairment to property values within the neighborhood.*

4. Will not impede the normal and orderly development and improvement of surrounding property for uses permitted in the district. *Surrounding properties are already developed. As such, there should be no impact on the normal and orderly development and improvement of surrounding properties.*
5. Will provide adequate utilities, access roads, drainage and other important and necessary community facilities. *Adequate utilities, access roads, drainage and other public improvements will be put in place for the proposed development.*
6. Will conform to the applicable regulations of the district in which it is located, except as the Village Board may in each instance modify such regulations. *The proposal is expected to conform to all applicable codes and requirements.*

**SECTION 2:**

The Mayor and Board of Trustees of the Village, after examining the Variation request, and the Findings and Recommendations of the Combined Plan Commission/Zoning Board of Appeals, have determined and find that, with respect to the requested Variation:

1. The requested variation arises from conditions that are unique to the subject property, that are not ordinarily found in the same zoning district and that are not a result of the owner's intentional action. *The variation is requested in order to maximize working space inside the proposed facility and parking spaces for customers and employees outside of the facility.*
2. The variation to be granted will not alter the essential character of the neighborhood in which the subject property is located, nor substantially or permanently impair use or development of adjacent property. *Staff does not believe the variation will alter the essential character of the neighborhood, similar variation requests have been granted to allow deviations to the larger building setback requirement.*
3. The strict application of the applicable standards will constitute an unnecessary physical hardship (not economic hardship) because the property cannot be used for an otherwise allowed use without coming into conflict with applicable site development standards. *In order for the proposed facility to function and operate properly, a properly sized building and adequate parking are necessary.*
4. The variation is the minimum action necessary to alleviate the hardship and observes the spirit of this UDO. *Staff believes the variation is the minimum action necessary for Bartel's Auto Clinic to operate the proposed facility properly.*
5. The variation desired will not adversely affect the public health, safety, or general welfare or impair the purposes or intent of the UDO or the comprehensive plan. *Staff does not believe the granting of the variation will be detrimental to the public welfare or injurious to the other property or improvements in the neighborhood in which the property is located.*

**SECTION 3:**

The Special Use Permit and Variation, as set forth in the above recitals, are hereby approved and granted to Bartel's Auto Clinic, subject to the conditions set forth in Section 4, upon the real estate commonly known as 160 S. Gary Avenue, Carol Stream, Illinois, and legally described as follows:

LOT 4 IN BARTEL INDUSTRIAL PARK SUBDIVISION, BEING A SUBDIVISION OF PART OF THE NORTH ½ OF SECTION 5, THE NORTH 39 NORTH, RANGE 10 EAST OF THE THIRD PRINCIPAL MERIDIAN, ACCORDING TO THE PLAT THEREOF RECORDED FEBRUARY 10, 2003 AS DOCUMENT R2003-053467 IN DUPAGE COUNTY, ILLINOIS.

Hereinafter referred to as the Subject Property.

**SECTION 4:**

The approval of the Special Use Permit and Variation granted in Sections 1 and 2 herein are subject to the following conditions:

1. That all improvements, including but not limited to the building, parking lot, and landscaping, must be built, installed, and maintained in accordance with the attached plans and exhibits;
2. That the landscape materials must be installed as shown on the attached landscape plan and that all materials shall be maintained in a healthy condition, with dead or dying materials being replaced in accordance with the approved plan on an annual basis;
3. That all repair and service work shall occur inside the building;
4. That no trucks or trailers shall be allowed to be stored in the parking lot;
5. That parking lot lighting which meets requirements of the UDO shall be required;
6. That all trash, refuse and recycling containers must be kept within the dumpster enclosure on the west side of the property, and that the gates to the enclosure must be kept closed at all times except when employees are accessing the enclosure or when the waste hauler is servicing the property;
7. That if any additional ground-mounted or roof mounted mechanical and utility equipment is installed, said equipment shall be screened per requirements of the UDO; and

8. That the site and business must be maintained and operated in accordance with all State, County and Village codes and regulations.

**SECTION 5:**

The Special Use Permit and Variation are hereby approved and granted as set forth in the following plans and exhibits:

1. Overall Site Plan (Exhibit A, received by the Community Development Department July 11, 2023), prepared by E.P. Doyle & Son, LLC., 1100 Wheaton Oaks Court, Wheaton, IL 60187.
2. Landscape Plan (Exhibit B, received by the Community Development Department July 11, 2023), prepared by E.P. Doyle & Son, LLC., 1100 Wheaton Oaks Court, Wheaton, IL 60187.
3. Photometric Plan (Exhibit C, received by the Community Development Department July 11, 2023), prepared by E.P. Doyle & Son, LLC., 1100 Wheaton Oaks Court, Wheaton, IL 60187.
4. Overall Floor Plan (Exhibit D, received by the Community Development Department July 11, 2023), prepared by E.P. Doyle & Son, LLC., 1100 Wheaton Oaks Court, Wheaton, IL 60187.
5. Exterior Elevations Plan (Exhibit E, received by the Community Development Department July 11, 2023), prepared by E.P. Doyle & Son, LLC., 1100 Wheaton Oaks Court, Wheaton, IL 60187.

**SECTION 6:**

This Ordinance shall be in full force and effect from and after passage, approval and publication in pamphlet form, provided, however, that this Ordinance is executed by the owners or such other party in interest, consenting to and agreeing to be bound by all of the terms and conditions contained within this Ordinance. Such execution and delivery to the Village shall take place within sixty (60) days after the passage and approval of this Ordinance or within such extension of time as may be granted in the discretion of the corporate authorities, by motion.

**SECTION 7:**

The failure of the owner or other party in interest, or a subsequent owner or other party in interest, to strictly comply with the terms and conditions of this Ordinance, after execution of this Ordinance, shall subject the owner or party in interest to the penalties set forth in Section 16-8-5 of the Carol Stream Code of Ordinances, and/or termination of the special use permit after notice and public hearing in accordance with the procedures required by the Carol Stream Code of Ordinances.

PASSED AND APPROVED THIS 7<sup>th</sup> DAY OF AUGUST, 2023.

AYES:

NAYS:

ABSENT:

---

Frank Saverino, Sr. Mayor

ATTEST:

---

Julia Schwarze, Village Clerk

I, Patrick Bartel, being the owner and/or party in interest of the Subject Property legally described in this ordinance, do hereby accept, concur, and agree to develop and use the Subject Property in accordance with the terms and conditions of this Ordinance, and I understand that if I do not do so, I am subject to the penalties set forth in Section 16-8-5 of the Carol Stream Code of Ordinances, and/or termination of the special use permit. Bartel's Auto Clinic further agrees to indemnify, hold harmless and defend the Village, and its officers, agents and employees from any and all claims, lawsuits, liabilities damages and costs incurred as a result of the approvals as granted herein.

---

Date

---

Owner/Party In Interest



RECEIVED

JUL 11 2023

COMMUNITY DEVELOPMENT DEPT

GARY AVENUE

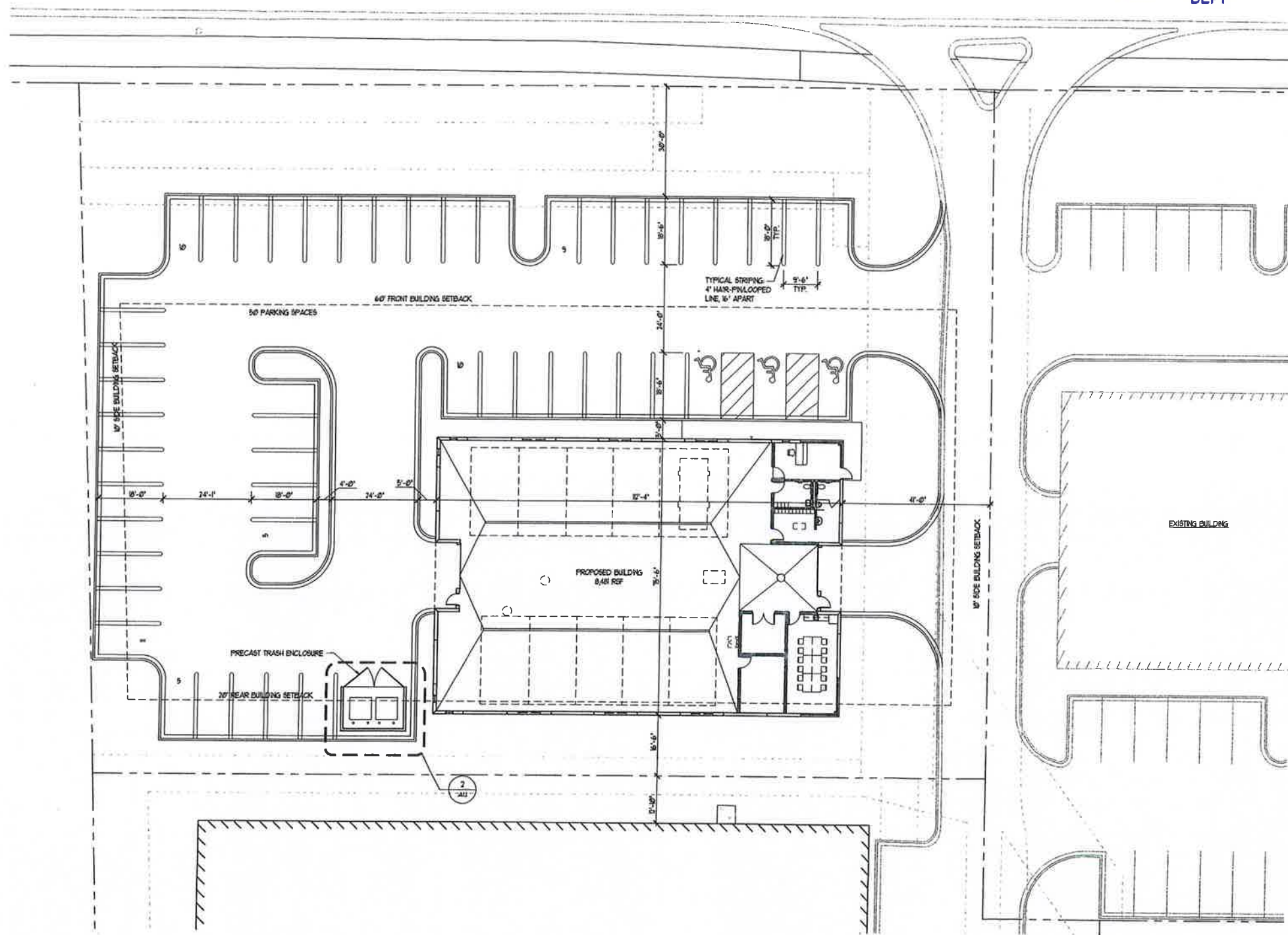

1 OVERALL SITE PLAN  
1/16" = 1'-0"

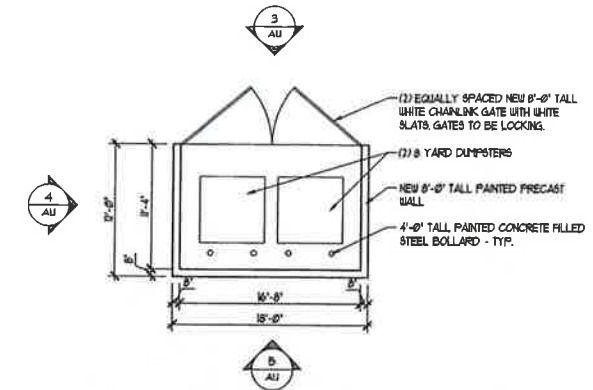

2 DUMPSTER ENCLOSURE PLAN  
1/8" = 1'-0"

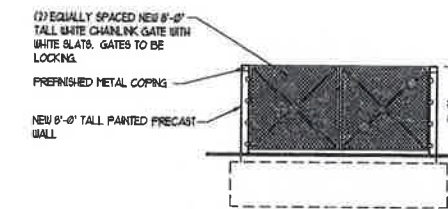

3 DUMPSTER ENCLOSURE ELEVATION  
1/8" = 1'-0"

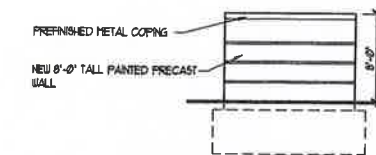

4 DUMPSTER ENCLOSURE ELEVATION  
1/8" = 1'-0"

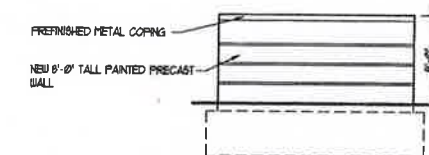

5 DUMPSTER ENCLOSURE ELEVATION  
1/8" = 1'-0"

SITE DATA	
ZONING:	I-INDUSTRIAL (GARY/NORTH AVE CORRIDOR OVERLAY DISTRICT)
SITE AREA:	1.044 ACRES
BUILDING AREA:	8,488 SF
FAR:	0.19 ACTUAL (0.29 MAX. ALLOWED)
BUILDING HEIGHT:	21'-0" ACTUAL (30'-0" MAX. ALLOWED)
BUILDING SETBACKS:	FRONT: 60'-0" SIDE: 10'-0" REAR: 20'-0"
PARKING:	PROVIDED: 50 SPACES (WITH 3 ADA SPACES) REQUIRED: 23 SPACES (AUTO ORIENTED BUSINESS - REPAIR & SERVICE: 6.826 NFA/250 = 26.6 x 5 = 13.3 SPACES PLUS 1 SPACE/SERVICE BAY = 10 SPACES)

EXHIBIT A

BARTEL'S AUTO CLINIC  
S Gary Avenue, Carol Stream, IL 60188

OVERALL SITE PLAN

2610 Lake Cook Road  
Suite 200  
Rosemead, IL 60015  
Ph: (617) 940-0300  
www.pdarchitects.com

Partners in Design  
ARCHITECTS

PROJECT NO:  
101923036  
DRAWN BY: EAW  
CHECKED BY: UWB  
DATE:  
07.10.23  
SHEET NO:

A1.1



GARY R. WEBER  
ASSOCIATES, INC.  
LAND PLANNING  
ECOLOGICAL CONSULTING  
LANDSCAPE ARCHITECTURE  
402 WEST LIBERTY DRIVE  
WHEATON, ILLINOIS 60187  
PHONE: 630-668-7197

CLIENT  
E.P. DOYLE & SON, LLC  
1100 WHEATON OAK COURT  
WHEATON, IL 60187

REV  
JUL 17 2023  
COMMUNITY DEVELOPMENT  
DEPT

## EXHIBIT B

### PLANTING DETAILS

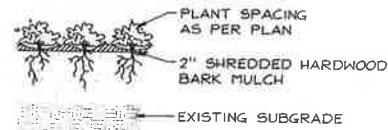

#### PERENNIALS AND GROUNDCOVERS NOT TO SCALE

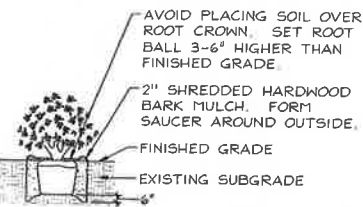

#### DECIDUOUS AND EVERGREEN SHRUBS NOT TO SCALE

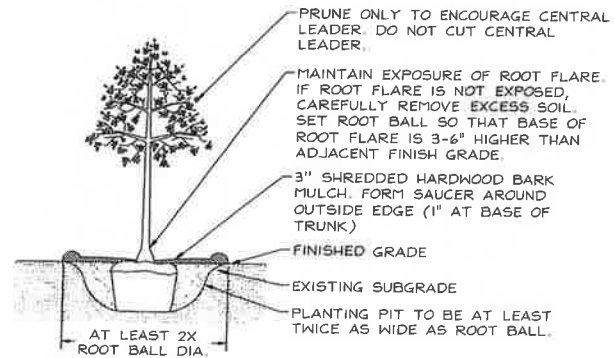

#### DECIDUOUS TREES NOT TO SCALE

### PLANT LIST

Key	Qty	Botanical/Common Name	Size	Remarks
<b>SHADE TREES</b>				
AF	3	Acer x freemanii 'Marmo' MARMO FREEMAN MAPLE	2 1/2" Cal.	
TC	3	Tilia cordata 'Greenspire' GREENSPIRE LITTLELEAF LINDEN	2 1/2" Cal.	
UM	3	Ulmus 'Marlon Glossy' TRIUMPH ELM	2 1/2" Cal.	
<b>ORNAMENTAL TREES</b>				
AG	3	Amelanchier x grandiflora APPLE SERVICEBERRY	6' Ht	Multi-Stem
CA	3	Carpinus caroliniana AMERICAN HORNBEAM	2" Cal.	Tree Form
<b>DECIDUOUS SHRUBS</b>				
HP	26	Hydrangea paniculata 'SMHPLOF' LITTLE QUICK FIRE HYDRANGEA	24" Tall	3' O.C.
IV	10	Itea virginica 'Little Henry' LITTLE HENRY VIRGINIA SWEETSPIRE	24" Tall	3' O.C.
PD	13	Physocarpus opulifolius 'Donna May' LITTLE DEVIL NINEBARK	24" Tall	3' O.C.
RA	71	Rhus aromatica 'Gro-low' GRO-LOW SUMAC	24" Wide	4' O.C.
<b>EVERGREEN SHRUBS</b>				
JK	27	Juniperus chinensis 'Kallays Compact' KALLAYS COMPACT PRITZER JUNIPER	24" Wide	4' O.C.
<b>ORNAMENTAL GRASSES</b>				
CK	7	Calamagrostis x acutiflora 'Karl Foerster' FEATHER REED GRASS	#1	30" O.C.
PL	7	Panicum virgatum 'Heavy Metal' HEAVY METAL SWITCHGRASS	#1	24" O.C.
<b>PERENNIALS</b>				
AB	23	Allium 'Summer Beauty' SUMMER BEAUTY ONION	#1	18" O.C.
<b>GROUNDCOVERS</b>				
LS	64	Liriope spicata CREEPING LILYTURF	#SP4	18" O.C.
<b>MISC. MATERIALS</b>				
22		SHREDDED HARDWOOD MULCH	C.Y.	
0.30		TURF SEED & EROSION CONTROL BLANKET	AC	

### GENERAL LANDSCAPE NOTES

- Contractor shall verify underground utility lines and is responsible for any damage.
- Contractor shall verify all existing conditions in the field prior to construction and shall notify landscape architect of any variance.
- Material quantities shown are for contractors convenience only. The Contractor must verify all material and supply sufficient materials to complete the job per plan.
- The landscape architect reserves the right to inspect plant materials either at place of growth or at site before planting, for compliance with requirements of variety, size and quality.
- Work shall conform to American Standard for Nursery Stock, State of Illinois Horticultural Standards, and Local Municipal requirements.
- Contractor shall secure and pay for all permits, fees, and inspections necessary for the proper execution of this work and comply with all codes applicable to this work.
- See General Conditions and Specifications for landscape work for additional requirements.

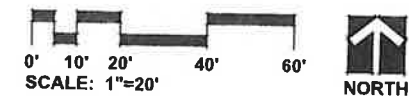
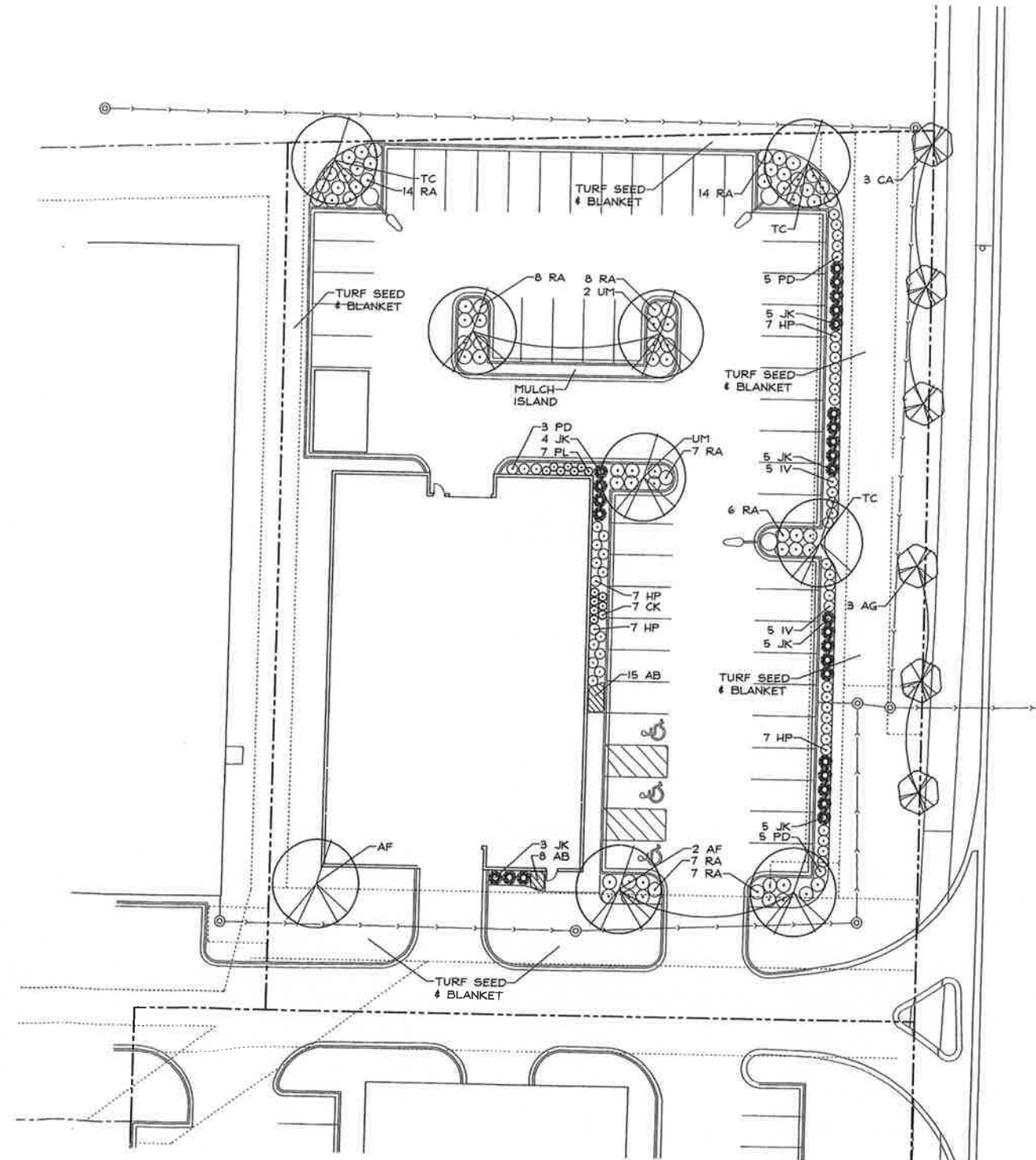

**BARTEL INDUSTRIAL PARK - LOT 4**  
 CAROL STREAM, ILLINOIS  
**LANDSCAPE PLAN**

REVISIONS  
7.10.2023

DATE: 6.5.2023  
PROJECT NO.: DS2302  
DRAWN: NKJ  
CHECKED: GFB  
SHEET NO.:

**L1.1**



RECEIVED  
 JUL 11 2023  
 COMMUNITY DEVELOPMENT  
 DEPT

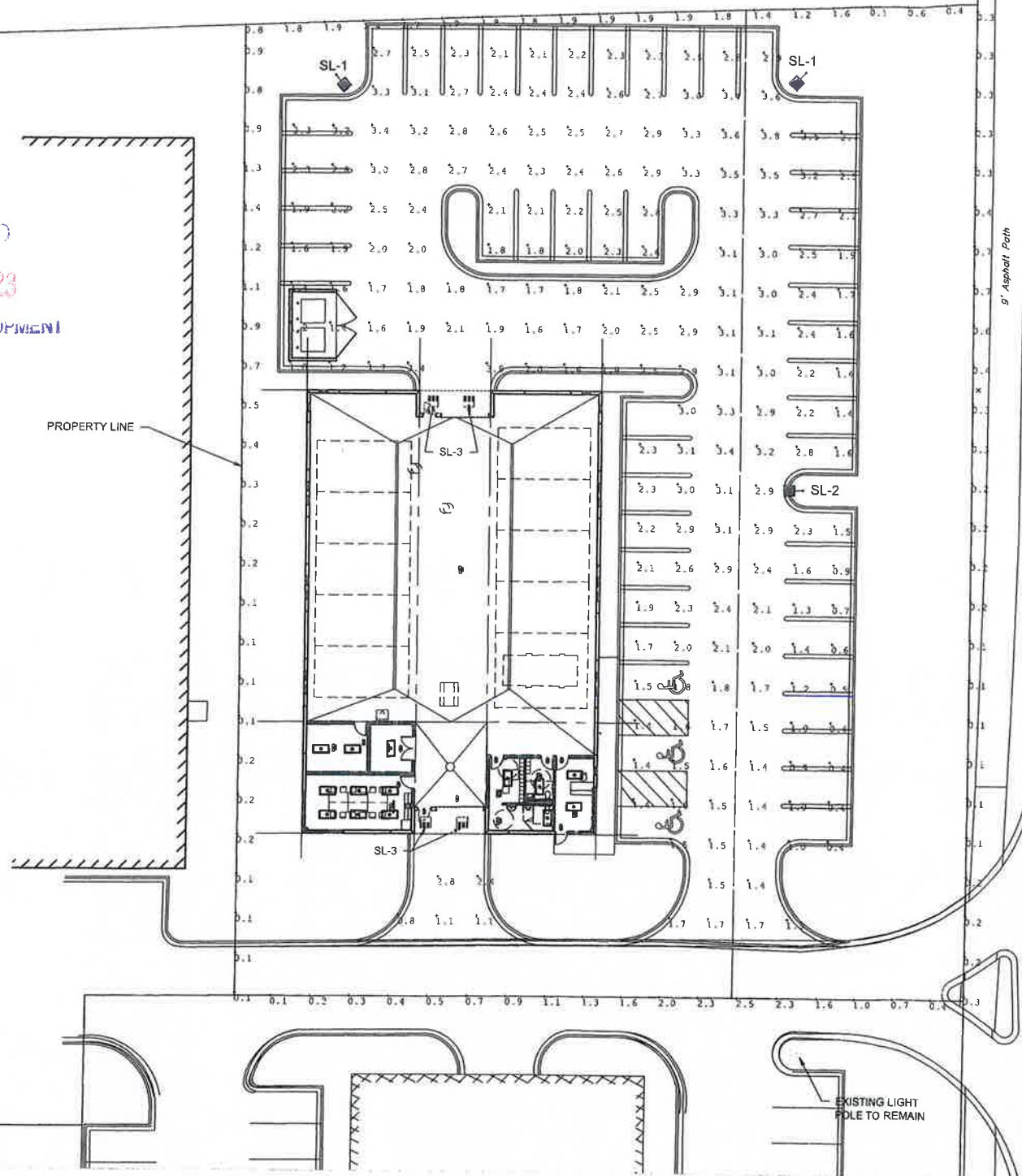

GARY AVENUE  
 (HEREFORE DEDICATED  
 PER DOC. 458803)

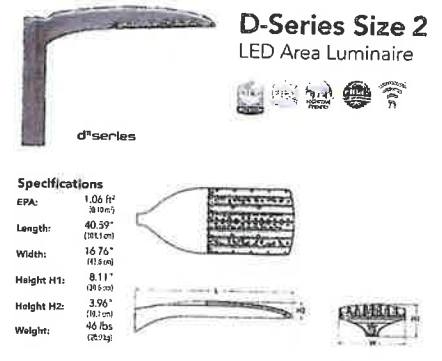

**Specifications**

EPA: 1.04 ft<sup>2</sup> (0.10 m<sup>2</sup>)  
 Length: 40.59" (1031 mm)  
 Width: 16.76" (425 mm)  
 Height H1: 8.11" (206 mm)  
 Height H2: 3.96" (100 mm)  
 Weight: 46 lbs (20.7 kg)

**Introduction**

The modern styling of the D-Series features a highly refined aesthetic that blends seamlessly with its environment. The D-Series offers the benefits of the latest in LED technology into a high performance, high efficacy, long-life luminaire.

The outstanding photometric performance results in sites with excellent uniformity, greater pole spacing and lower power density. D-Series outstanding photometry aids in reducing the number of poles required in area lighting applications with typical energy savings of up to 80% vs. 1000W HID and expected service life of over 100,000 hours.

**EXAMPLE: DSX2 LED P7 40K 70CRI T3M MVOLT SPA NLTAIR2 PIRHN DDBXD**

DSX2 LED	Forward optics	Alternative Part no.	TSM	Type V medium	MVOLT (120V-277V) <sup>1</sup>	Shipped included
P1	P5	70CRI	T15	Type V medium	120V (4000) <sup>1</sup>	SPA Square pole mounting (18" dia)
P2	P6	70CRI	T16	Type V medium	120V (4000) <sup>1</sup>	SPA Square pole mounting (18" dia)
P3	P7	70CRI	T17	Type V medium	120V (4000) <sup>1</sup>	SPA Square pole mounting (18" dia)
P4	P8	70CRI	T18	Type V medium	120V (4000) <sup>1</sup>	SPA Square pole mounting (18" dia)
P5	P9	70CRI	T19	Type V medium	120V (4000) <sup>1</sup>	SPA Square pole mounting (18" dia)
P6	P10	70CRI	T20	Type V medium	120V (4000) <sup>1</sup>	SPA Square pole mounting (18" dia)
P7	P11	70CRI	T21	Type V medium	120V (4000) <sup>1</sup>	SPA Square pole mounting (18" dia)
P8	P12	70CRI	T22	Type V medium	120V (4000) <sup>1</sup>	SPA Square pole mounting (18" dia)
P9	P13	70CRI	T23	Type V medium	120V (4000) <sup>1</sup>	SPA Square pole mounting (18" dia)
P10	P14	70CRI	T24	Type V medium	120V (4000) <sup>1</sup>	SPA Square pole mounting (18" dia)
P11	P15	70CRI	T25	Type V medium	120V (4000) <sup>1</sup>	SPA Square pole mounting (18" dia)
P12	P16	70CRI	T26	Type V medium	120V (4000) <sup>1</sup>	SPA Square pole mounting (18" dia)

LITHONIA LIGHTING  
 COMMERCIAL OUTDOOR  
 One Lithonia Way • Conyers, Georgia 30012 • Phone 1 800 765 SERV (378) • www.lithonia.com  
 © 2011-2023 Acuity Brands Lighting, Inc. All rights reserved.

- NOTES:
- THE LIGHT POLE LOCATIONS ON THIS PLAN SHOW THE RECOMMENDED PLACEMENT. ADJUSTMENTS TO THESE LOCATIONS MAY BE REQUIRED TO ACCOMMODATE SITE CONDITIONS.
  - CALCULATION AREAS ABOVE ARE TAKEN WITHIN THE LIMITS OF PROPOSED PARKING LOT PAVEMENT AS SHOWN ON THIS PLAN.
  - THE PHOTOMETRIC PLAN WAS PREPARED USING THE FIXTURES IN THE SCHEDULE ON THIS SHEET. NO SUBSTITUTIONS ARE PERMITTED WITHOUT APPROVAL BY THE ENGINEER.

EXHIBIT C

CALCULATED LIGHTING ILLUMINANCE LEVELS (FOOT CANDLES)

	AVERAGE	MAX	MIN	AVG/MIN	MAX/MIN
PARKING LOT	2.20	3.9	0.4	5.50	9.75

PROPOSED SITE LIGHTING FIXTURE SCHEDULE

SYMBOL	DESCRIPTION	QUANTITY	LLF	COLOR	MOUNTING	CONFIG.	CATALOG NO. & NOTES
SL-1	LITHONIA LIGHTING, D-SERIES SIZE 2 LED AREA LIGHT, LUMINAIRE POWER PACKAGE P2, FORWARD THROW MEDIUM DISTRIBUTION	2	0.90	4000K	25'-0" POLE ON 3'-0" CONCRETE FOUNDATION, 28'-0" MOUNTING HEIGHT	1 FIXTURE	DSX2-LED-P2-40K-70CRI-TFTM-MVOLT
SL-2	LITHONIA LIGHTING, D-SERIES SIZE 2 LED AREA LIGHT, LUMINAIRE POWER PACKAGE P2, TYPE II MEDIUM DISTRIBUTION	1	0.90	4000K	25'-0" POLE ON 3'-0" CONCRETE FOUNDATION, 28'-0" MOUNTING HEIGHT	1 FIXTURE	DSX2-LED-P2-40K-70CRI-T2M-MVOLT
SL-3	LITHONIA LIGHTING, CNY LED CANOPY/CEILING LUMINAIRE, POWER PACKAGE P0	4	0.90	4000K	12'-6" MOUNTING HEIGHT, IN BUILDING SOFFIT	1 FIXTURE	CNY LED-P0-40K-MVOLT

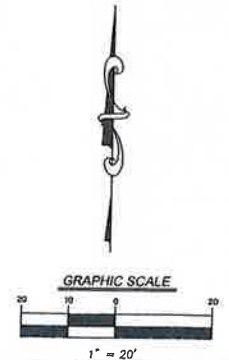

PRELIMINARY PHOTOMETRIC PLAN  
 BARTEL AUTO CLINIC  
 CAROL STREAM GARY AVE. AND ST. CHARLES RD. ILLINOIS

PROJECT NO: 230545  
 PROJECT MANAGER: MJR  
 DESIGNED BY: MJR  
 DRAWN BY: JRR

ORIGINAL ISSUE DATE: DECEMBER 2, 2022

NO.	DATE	DESCRIPTION

DRAWING NO. P1.0

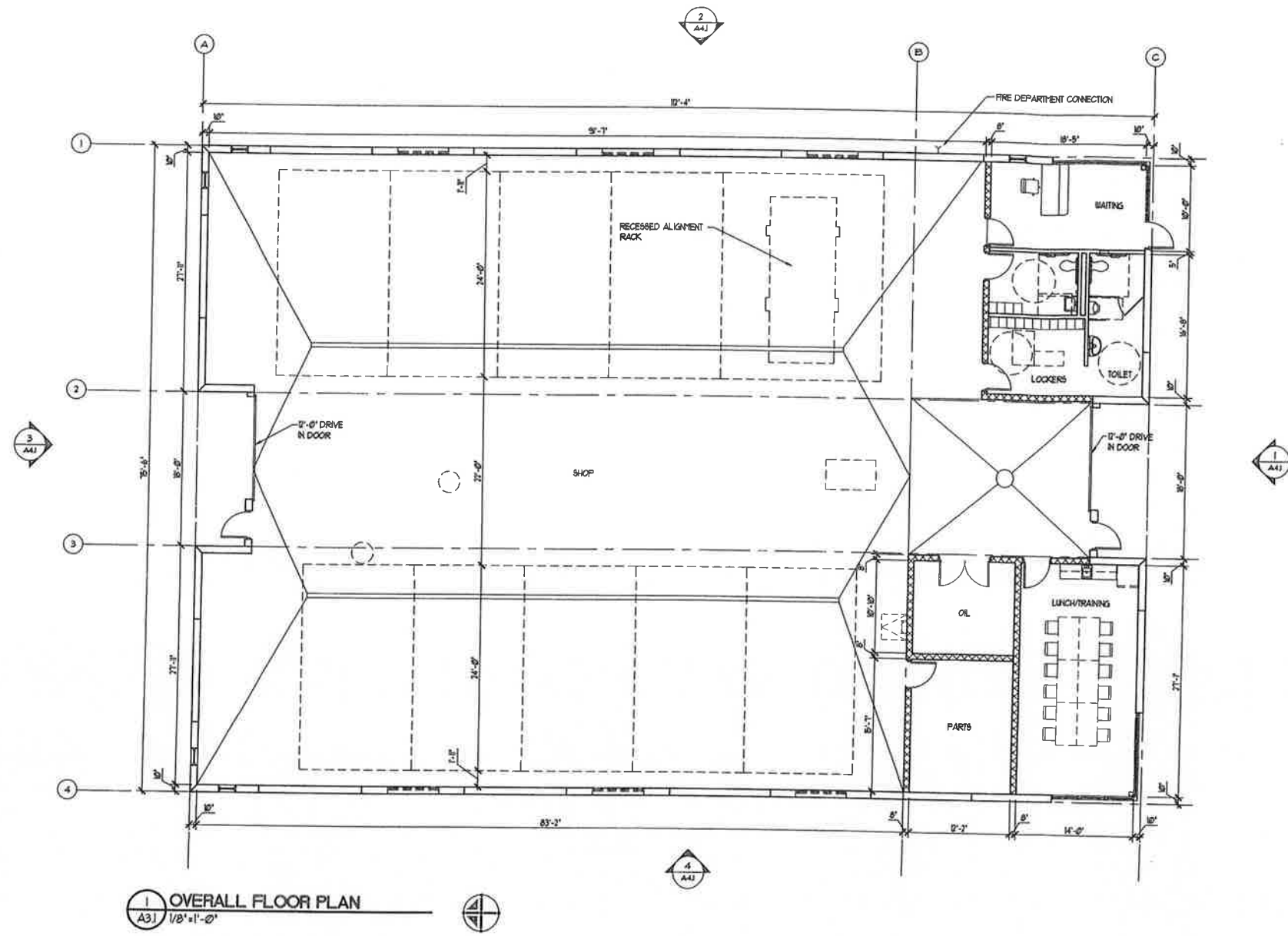

JUL 17 2023  
 COMMUNITY DEVELOPMENT  
 DEPT

1 OVERALL FLOOR PLAN  
 A3.1 1/8" = 1'-0"

EXHIBIT D

BARTEL'S AUTO CLINIC  
 S Gary Avenue, Carol Stream, IL 60188  
 OVERALL FLOOR PLAN

2610 Lee Cook Road  
 Suite 280  
 Riverwoods, IL 60015  
 Ph: (847) 940-0300  
 www.pdadarchitects.com

Partners in Design  
 ARCHITECTS

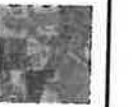

PROJECT NO:  
 1923036  
 DRAWN BY: EAW  
 CHECKED BY: UHB  
 DATE: 07/10/23  
 SHEET NO:

A3.1

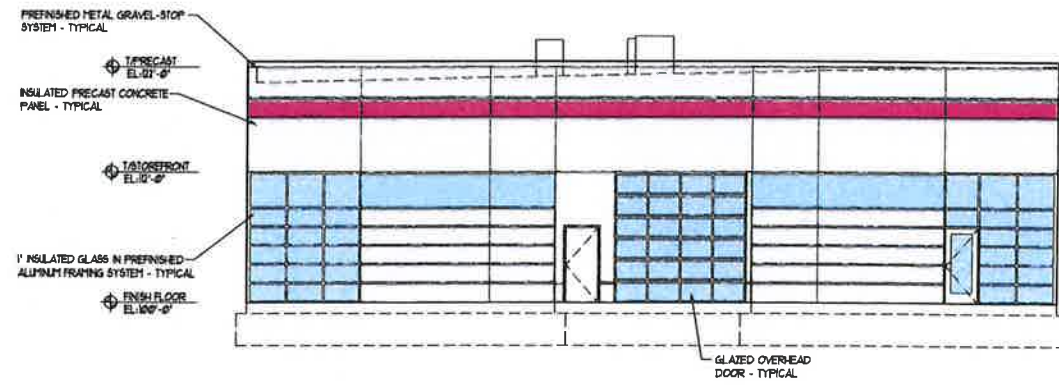

1 SOUTH ELEVATION  
 A4.1 1/8"=1'-0"

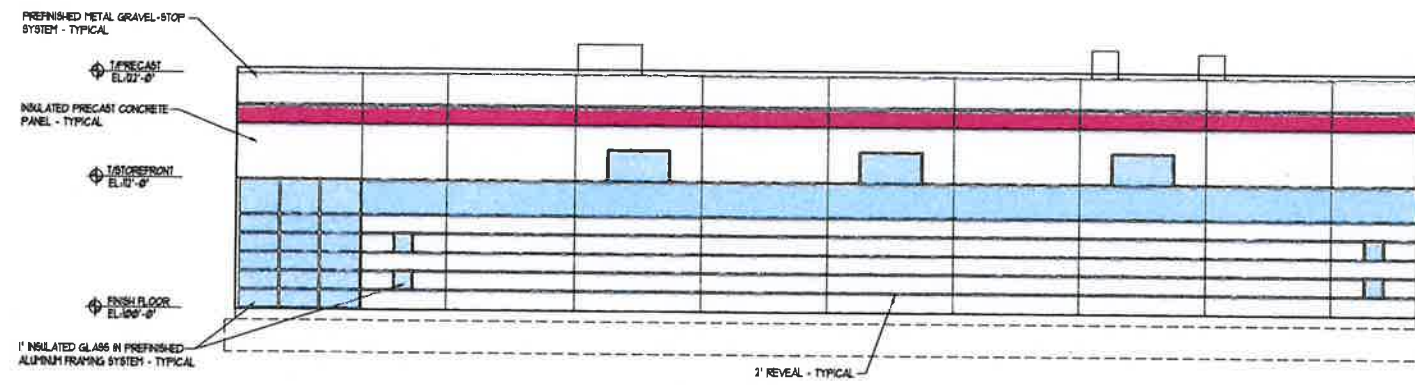

2 EAST ELEVATION  
 A4.1 1/8"=1'-0"

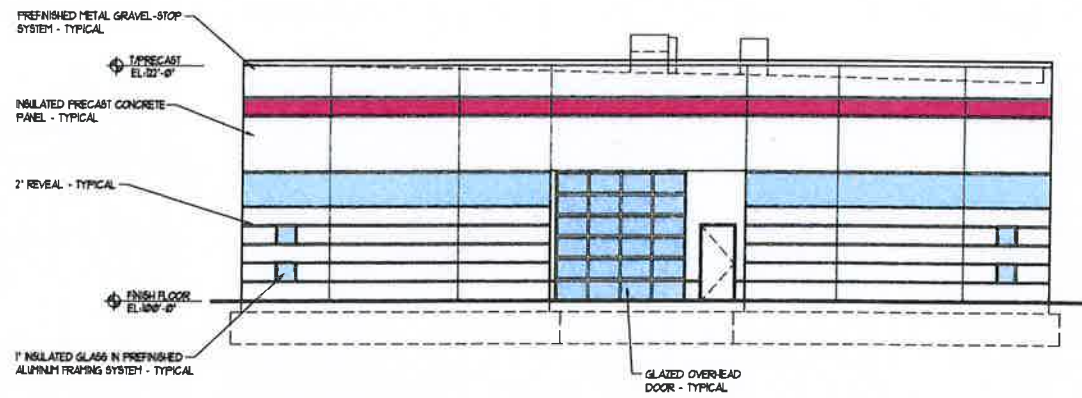

3 NORTH ELEVATION  
 A4.1 1/8"=1'-0"

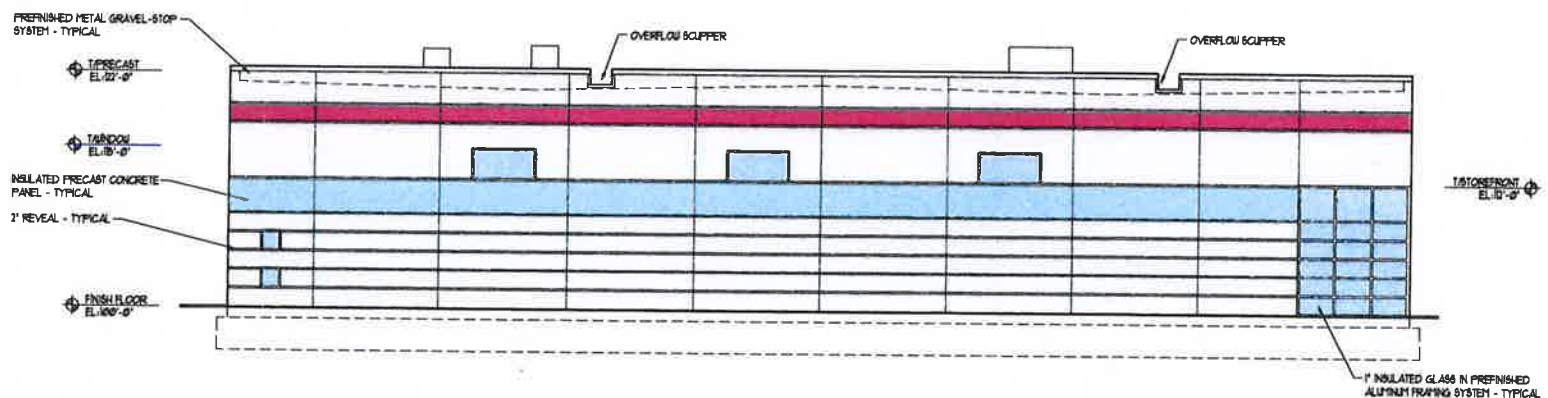

4 WEST ELEVATION  
 A4.1 1/8"=1'-0"

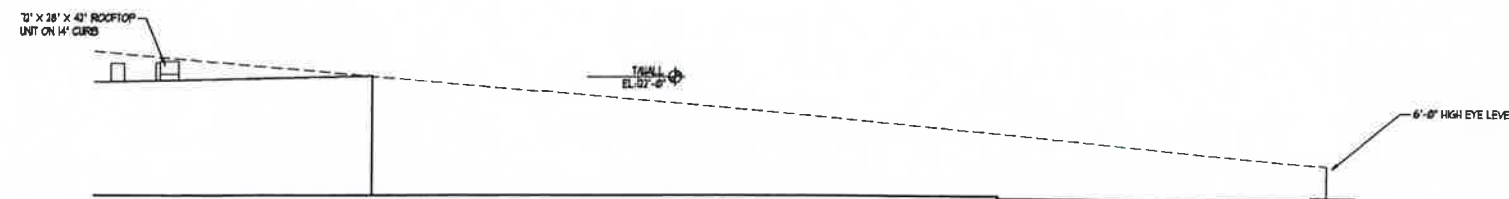

5 SIGHT LINE 1 - STREET  
 A4.1 1/16"=1'-0"

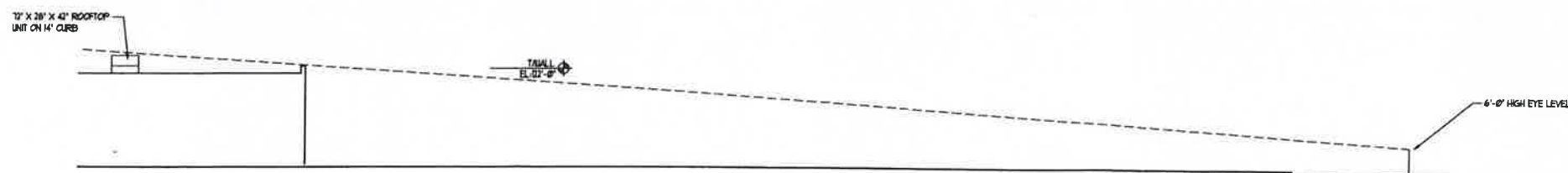

6 SIGHT LINE 2 - INTERSECTION  
 A4.1 1/16"=1'-0"

EXHIBIT E

BARTEL'S AUTO CLINIC  
 S Gary Avenue, Carol Stream, IL 60188  
 EXTERIOR ELEVATIONS

2610 Lake Cook Road  
 Suite 280  
 Riverwoods, IL 60015  
 Ph: (630) 940-0300  
 www.pdnarchitects.com

**Partners in Design**  
 ARCHITECTS



PROJECT NO: 1923036  
 DRAWN BY: EAU CHECKED BY: WHB  
 DATE: 07.10.23  
 SHEET NO:

A4.1

ORDINANCE NO. 2023-08-\_\_\_\_\_

**AN ORDINANCE AMENDING THE CAROL STREAM CODE OF ORDINANCES, CHAPTER 13, ARTICLE 2, SECTION 13-2-37 SEWER LINE MAINTENANCE/ REPLACEMENT**

**BE IT ORDAINED BY THE MAYOR AND BOARD OF TRUSTEES OF THE VILLAGE OF CAROL STREAM, DUPAGE COUNTY, ILLINOIS, IN THE EXERCISE OF ITS HOME RULE POWERS, as follows:**

**SECTION 1:** The Carol Stream Code of Ordinances, Chapter 13, Article 2, Section 13-2-37 is hereby amended in its entirety which shall read as follows:

**13-2-37 Sewer Line Maintenance/Replacement**

- (A) The property owner is responsible for the maintenance and repair of the private sewer line from their structure to the main sewer or Public Sewer including the connection into the main/Public Sewer.
- (B) In the event the property owner finds it necessary to excavate the private sewer line for maintenance or replacement, such excavation shall be the property owner's responsibility.
- (C) In those instances when property owners have had to excavate and as a result the sidewalk, curb and street have been dug out or damaged, the property owner will be responsible for the restoration of the street (surface and sub-surface) curb and sidewalk.
- (D) In those instances where Subsection C. is involved, it is recommended tunneling under the curb and sidewalk whenever practical. Sidewalk and curb must be cut when removal is required.
- (E) All work, as it is related to the replacement and/or repair of the private sewer line, shall be in conformance with the Village standard construction specifications and will be inspected by a Duly Authorized Agent of the Village during the repair and replacement.
- (F) The Village will participate in the repair or replacement of a private sanitary sewer service line located under the paved roadway within the Village's right-of-way subject to the following:
  - 1. The sanitary sewer service line has been televised by the property owner and based on the evidence provided to the Village, to include video and evidence of location of the potential issue, the Village Engineer or Public Works Director have determined the sewer service line under the paved roadway presents the potential to damage the Village's paved roadway or the Village's sewer main if uncorrected; and
  - 2. The only method of repair or replacement of the sanitary sewer service line requires excavation of the Village's paved roadway.
  - 3. The Village will reimburse the property owner fifty-percent (50%) of the costs toward the repair or replacement of the private sanitary sewer line under the Village paved roadway and pavement repair in an amount not to exceed \$10,000. The applicant will be responsible for all additional costs associated with the sanitary sewer service line repair or replacement in excess of these amounts.
  - 4. The applicant will indemnify, hold and release the Village from any and all liability arising from the repair of the sanitary sewer service line by the Village.

5. Repair or replacement of any private sanitary sewer line outside of a Village paved roadway will be not be eligible for reimbursement and shall remain the responsibility of the homeowner pursuant to subsections (A) through (E) of this section.
6. In all cases, maintenance of the entire private sanitary sewer service line shall remain the responsibility of the property owner, including but is not limited to flushing to clear blockages and root cutting in the property owner's service line.

**SECTION 2:** This Ordinance shall be in full force and effect from and after its passage and approval by law.

PASSED AND APPROVED THIS 7<sup>th</sup> DAY OF AUGUST, 2023.

AYES:

NAYS:

ABSENT:

\_\_\_\_\_  
Frank Saverino, Sr., Mayor

ATTEST:

\_\_\_\_\_  
Julia Schwarze, Village Clerk

*Village of Carol Stream*  
Interdepartmental Memo

TO: Robert Mellor, Village Manager

FROM: Adam Frederick, Assistant Village Engineer 

DATE: August 1, 2023

RE: 130 Easy Street, Easy Street Corp., Acceptance of Public Improvements and Reduction of Security for Public Improvements

As part of the development of the property located at 130 Easy Street, Easy Street Corp. proposed to extend public storm sewer within the Easy Street right-of-way from the existing public detention basin at the intersection of Gary Avenue and St. Charles Road to their 130 Easy Street parcel.

The developer has submitted the necessary paperwork including: waivers of lien and a bill of sale. Engineering and Public Works staff have inspected the items to be accepted and any deficiencies have been corrected. The Village Attorney has reviewed and approved the bill of sale.

We therefore recommend that the public improvements related to 130 Easy Street be accepted by the Village of Carol Stream and the Security for Public Improvements in the amount of \$56,878.80 be reduced to a maintenance period amount of \$5,170.80 (10%) for a period of one year.

The Bill of Sale with exhibit and the Inventory of Public Improvements shall be attached to the Resolution per the Village Attorney's recommendation.

Cc: Bill Cleveland, Director of Engineering Services  
Brad Fink, Interim Director of Public Works  
Jon Batek, Finance Director  
James Rhodes, Village Attorney

Attachments:  
Bill of Sale w. Exhibit 1  
Inventory of Public Improvements



**RESOLUTION NO. \_\_\_\_\_**

**A RESOLUTION ACCEPTING PUBLIC IMPROVEMENTS AND  
REDUCTION OF SECURITY FOR PUBLIC IMPROVEMENTS –  
EASY STREET CORP. – 130 EASY STREET**

WHEREAS, the public improvements for Easy Street Corp. located at 130 Easy Street have been completed in conformance with the approved plans and specifications, and a bill of sale has been received.

BE IT RESOLVED BY THE MAYOR AND BOARD OF TRUSTEES OF THE VILLAGE OF CAROL STREAM, DUPAGE COUNTY, ILLINOIS, IN THE EXERCISE OF ITS HOME RULE POWERS, as follows:

SECTION 1: That the Village of Carol Stream does hereby accept the public improvements for Easy Street Corp. public storm sewer improvements, 130 Easy Street, PIN No. 05-05-206-023. The Bill of Sale for the Public Improvements for Easy Street Corp. in Lot 1 of Mergenthaler's Consolidation, which is located at 130 Easy Street, is attached hereto and marked Exhibit A along with the Inventory of Public Improvements marked Exhibit B.

SECTION 2: That the Village of Carol Stream does hereby approve a reduction of the security for public improvements from \$56,878.80 by \$51,708.00 to \$5,170.80 (10%) for a period of one year as required by the Unified Development Ordinance.

SECTION 3: This Resolution shall be in full force and effect from and after its passage and approval as provided by law.

PASSED AND APPROVED THIS 7<sup>th</sup> DAY OF AUGUST, 2023.

AYES:

NAYS:

ABSENT:

\_\_\_\_\_  
Frank Saverino, Sr., Mayor

ATTEST:

\_\_\_\_\_  
Julia Schwarze, Village Clerk

**Bill of Sale for  
the Public Improvements in  
Mergenthaler's Consolidation  
(130 Easy Street)**

Seller, **Easy Street Corp** (the "Owner") is the current owner of the real property comprising Lot 1 in Mergenthaler's Consolidation (referred to as the "Subdivision"), which is located at 130 Easy Street, Carol Stream, Illinois. The Plat of Consolidation was filed on August 25, 2021 with the DuPage County Recorder of Deeds Office and recorded as Document Number R2021-127634, and is incorporated herein by reference. In accordance with the applicable provisions of the Unified Development Ordinance of the Village of Carol Stream, the Owner caused certain improvements to be constructed within the Easy Street Public Right-of-Way, including but not limited to storm sewer. All such improvements are referred to as the "Public Improvements".

In accordance with the applicable provisions of Chapter 16, Article 8-4(O)(9) (Acceptance of Public Improvements) of the Carol Stream Unified Development Ordinance, the Owner desires for the Village of Carol Stream ("Village") to accept the Public Improvements and to convey title to and ownership and maintenance responsibility to the Village for the Public Improvements.

The Public Improvements are described below and are located as shown on the (Public Improvements Plan) from the final engineering set of plans entitled (Engineering Improvement Plans for Parking Lot Improvements 130 Easy Street Carol Stream, Illinois, drawn by Pinnacle Engineering Group, last revised May 18, 2022), (the Plans) a copy of which is attached hereto as **Exhibit "1"** and made a part hereof:

- A. Easy Street Storm Sewer: Each and every part and item of storm sewer and drainage system, including sewer pipes and accessory items, located in the Easy Street Right of Way shown on Exhibit "1".

The Owner, in consideration of Ten and No/100 Dollars (\$10.00), receipt whereof is acknowledged as adequate, good and valuable consideration, does sell, assign, transfer and set over title and ownership to the Village of Carol Stream, an Illinois municipal corporation, of the Public Improvements as described herein and as shown on the attached Exhibit "1".

The Owner covenants to the Village that: (1) the Owner is the lawful owner of the Public Improvements; (2) the Public Improvements are free from all liens and encumbrances; (3) the Owner has the right to convey title to the accepted Public Improvements; and (4) the Owner will defend and hold the Village and its appointed and elected officials, president and trustees, employees, engineers, attorneys, volunteers and representatives harmless against the claims and demands of all persons with regard to ownership of and payment for construction of the accepted Public Improvements; and (5) the execution of this Agreement is an authorized act of the Owner.

The Owner hereby provides a limited warranty that the Public Improvements shall not, for a period of one (1) year from the date of this Bill of Sale, require repair or replacement due to failure of design, material or workmanship utilized in their installation.



**130 Easy Street - Easy Street Corp.  
Inventory of Public Improvements**

ITEM	QUANTITY	UNIT	EST. UNIT PRICE	TOTAL
<b>Storm Sewer System</b>				
6" Ductile Iron Storm Pipe	70	LF	\$ 35.00 \$	2,450.00
12" RCP Storm Pipe	255	LF	\$ 35.00 \$	8,925.00
48" Storm Manhole	2	EA	\$ 2,500.00 \$	5,000.00
48" Storm Catch Basin	0	EA	\$ 3,000.00 \$	
Connection To Existing Storm Structure	1	EA	\$ 750.00 \$	750.00
Trench Backfill	252	LF	\$ 15.00 \$	3,780.00
Miscellaneous Pavement and Turf Restoration	1	LS	\$ 28,513.00 \$	28,513.00
			<b>Sum of Improvements \$</b>	<b>49,418.00</b>

# EXHIBIT "1"

6/25/2023, 8:59 AM - 2:00 PM (EST) 10/25/23 - 11/22 - ENGINEERING/UTILITY/STREET-C-8 PUBLIC IMPROVEMENTS - THESE PLANS AND SPECIFICATIONS ARE COPYRIGHT PROTECTED AND MAY NOT BE USED IN WHOLE OR IN PART WITHOUT THE WRITTEN CONSENT OF PINNACLE ENGINEERING GROUP, LLC.

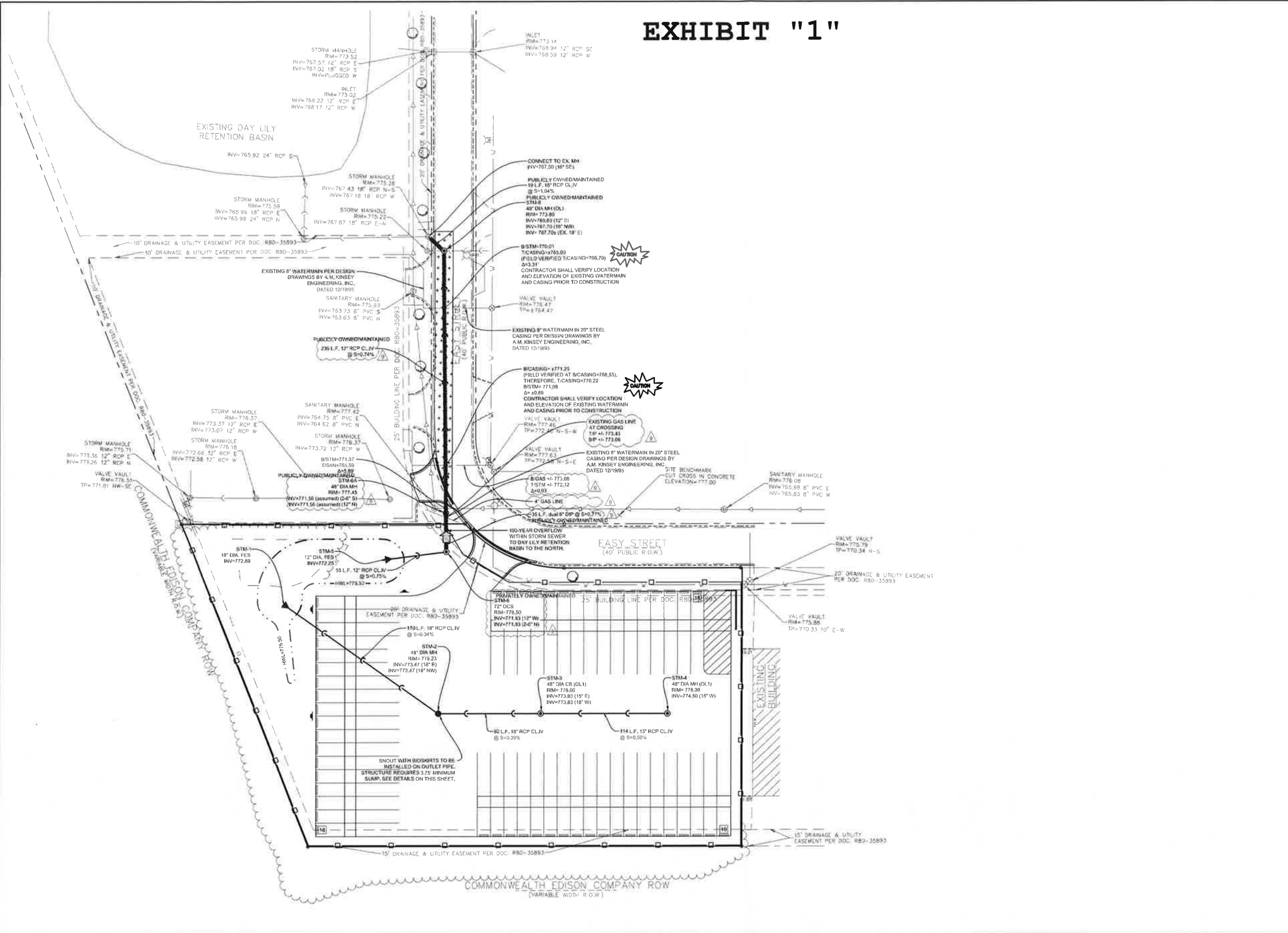

- ### UTILITY NOTES
- CONTRACTOR SHALL CONTACT 811 PRIOR TO CONSTRUCTION AND NOTIFY ENGINEERING OF ANY CONFLICTS WITH THE PROPOSED IMPROVEMENTS.
  - CONTRACTOR SHALL BE RESPONSIBLE FOR OBTAINING ALL PERMITS REQUIRED FOR UTILITY CONSTRUCTION.
  - ALL EXISTING INFORMATION AND EXISTING UTILITIES SHOWN ON THIS PLAN HAVE BEEN DETERMINED FROM THE BEST INFORMATION AVAILABLE AND ARE GIVEN FOR THE CONVENIENCE OF THE CONTRACTOR. THE ENGINEER ASSUMES NO RESPONSIBILITY FOR THEIR ACCURACY. PRIOR TO THE START OF ANY DEMOLITION ACTIVITY, THE CONTRACTOR SHALL NOTIFY THE UTILITY COMPANIES FOR LOCATION OF EXISTING UTILITIES.
  - ALL UTILITIES SHALL BE COORDINATED WITH THE APPROPRIATE UTILITY COMPANY OR AGENCY.
  - GRADING, PARKING, AND UTILITY LAYOUT HAVE BEEN PREPARED BASED UPON ARCHITECTURAL INFORMATION. SUBSEQUENT ARCHITECTURAL CHANGES MAY EXIST AND CONTRACTOR SHALL REFER TO ARCHITECTURAL PLANS FOR ADDITIONAL INFORMATION. IN CASE OF DISCREPANCIES BETWEEN ARCHITECTURAL PLANS AND CIVIL PLANS, THE CIVIL PLANS SHALL TAKE PRECEDENCE.
  - ALL UTILITY DIMENSIONS ARE TO CENTER OF PIPE OR CENTER OF STRUCTURE UNLESS OTHERWISE NOTED.
  - CONTRACTOR SHALL CONTACT EACH UTILITY COMPANY AND COORDINATE FINAL LOCATIONS OF ALL ELECTRIC, GAS, AND TELEPHONE SERVICES PRIOR TO START OF CONSTRUCTION. ALL UTILITY SLEEVES AND PIPE SHALL BE INCLUDED IN BID.
  - CONTRACTOR SHALL LOCATE ALL EXISTING SEWER AND WATERMAIN LOCATION, SIZE, ELEVATION, AND CONDITION AT POINTS OF CONNECTION AND WHERE PROPOSED UTILITIES SHALL CROSS OR POTENTIALLY COME IN CONFLICT WITH EXISTING LINES PRIOR TO CONSTRUCTION. CONTRACTOR SHALL NOTIFY ENGINEERING OF ANY DISCREPANCIES OR CONFLICTS.
  - UNDERGROUND IMPROVEMENTS SHALL BE CONSTRUCTED AND TESTED IN ACCORDANCE WITH THE MUNICIPALITY, THE STANDARD SPECIFICATIONS FOR WATER AND SEWER MAIN CONSTRUCTION IN ILLINOIS AND STANDARD SPECIFICATIONS FOR ROAD AND BRIDGE CONSTRUCTION, IDOT. IN THE EVENT OF CONFLICTING GUIDELINES, THE MORE RESTRICTIVE SHALL GOVERN.
  - PUBLICLY OWNED STORM STRUCTURES SHALL SAY "VILLAGE OF CAROL STREAM STORM" AND PRIVATE STORM STRUCTURES SHALL SAY "STORM". STORM STRUCTURES 6, 7 AND 8 WILL BE PUBLICLY OWNED AND MAINTAINED.
  - ALL OPEN LID STORM STRUCTURES SHALL HAVE NEENAH R-2540 LIDS, UNLESS OTHERWISE NOTED.

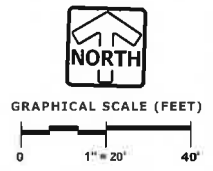

**PINNACLE ENGINEERING GROUP**  
 CHICAGO OFFICE:  
 1051 E. MAIN ST. | SUITE 217  
 EAST OLMDEN, IL 60118  
 (815) 555-5300  
 CHICAGO OFFICE: NATURAL RESOURCES | SURVEYING

**PLAN | DESIGN | DELIVER**  
**PARKING LOT IMPROVEMENTS**  
**130 EASY STREET**  
**CAROL STREAM, IL**

### REVISIONS

1	PER VILLAGE OF CAROL STREAM	11/29/21	5	PER CLIENT COMMENTS	05/12/22
2	PER VILLAGE COMMENTS	02/10/22	6	PER VILLAGE COMMENTS	05/18/22
3	PER VILLAGE COMMENTS	04/08/22	7	DOLLY PAD SHIFT PER OWNER	08/18/22
4	PER VILLAGE COMMENTS	04/15/22	8	FIELD CONDITIONS (GAS)	11/01/22

**PUBLIC IMPROVEMENTS**

REG. JOB No. 2367-2023-IL  
 SHEET  
**C-8**  
 of  
**C-10**

www.pinnacle-engr.com  
**PARKING LOT IMPROVEMENTS - PUBLIC IMPROVEMENTS**

RESOLUTION NO. \_\_\_\_\_

**A RESOLUTION DECLARING SURPLUS PROPERTY  
OWNED BY THE VILLAGE OF CAROL STREAM**

WHEREAS, in the opinion of the corporate authorities of the Village of Carol Stream, Illinois, it is no longer necessary or useful, or for the best interests of the Village of Carol Stream to retain ownership of the personal property described in "Exhibit A"; and

WHEREAS, the described personal property has been determined by the corporate authorities of the Village of Carol Stream to have negligible value to the Village; and

WHEREAS, it has been determined by the Mayor and Board of Trustees of the Village of Carol Stream to dispose of the surplus property.

NOW, THEREFORE, BE IT RESOLVED BY THE MAYOR AND BOARD OF TRUSTEES OF THE VILLAGE OF CAROL STREAM, DUPAGE COUNTY, ILLINOIS, IN THE EXERCISE OF ITS HOME RULE POWER, as follows:

SECTION 1: That the Mayor and Board of Trustees of the Village of Carol Stream find that the personal property described in Exhibit "A", now owned by the Village of Carol Stream, is no longer useful and authorize its disposal per the attached memorandum dated August 7, 2023.

SECTION 2: This resolution shall be in full force and effect from and after its passage and approval in the manner provided by law.

PASSED AND APPROVED THIS 7<sup>th</sup> DAY OF AUGUST, 2023

AYES:

NAYS:

ABSENT:

\_\_\_\_\_  
Frank Saverino, Sr., Mayor

ATTEST:

Julia Schwarze, Village Clerk

## EXHIBIT "A"

# *Village of Carol Stream* Interdepartmental Memo

TO: Bob Mellor, Village Manager  
FROM: Brad C. Fink, Interim Director of Public Works  
DATE: August 7, 2023  
RE: Surplus Declaration – Public Works Equipment

Public Works has identified the following village property that is no longer necessary or useful to the Village and is seeking approval to be declared surplus.



**Hach CL17 Chlorine Analyzer  
SN#9844**

This unit was originally installed in 2017 at the Kuhn Rd. Pump Station to monitor chlorine levels in the water system. This unit is past its useful life and has already been replaced with a new model. Staff recommends this unit be declared surplus and scrapped.

**Shelter Coat Garage, 16' x 16' x 44'  
Model: NLE7SL-95944**

The WRC has (1) one shelter garage, which had been used to provide weather protection over a portable belt filter press during the period of temporary dewatering for the Dewatering Improvements Project. The shelter was heavily damaged during a severe weather event which occurred on Friday, July 14, 2023. Staff recommends this item be declared surplus and scrapped.



Staff recommends these items be declared surplus by the Mayor and Board of Trustees and the Village Manager be authorized to dispose of the property as proposed pursuant to the provisions of Section 5-8-15 of the Carol Stream Code of Ordinances.



*Village of Carol Stream*  
**Interdepartmental Memo**

**TO:** Robert Mellor, Village Manager  
**FROM:** Ann Delort, Secretary *AD*  
**DATE:** August 2, 2023  
**RE:** Raffle License Application  
Windsor Park-Benevolent Care Campaign

Windsor Park is sponsoring their Annual Benevolent Care Campaign event to benefit the Windsor Park Benevolent Care Fund. The benefit will be held at the Windsor Park Campus on Sunday, August 20, 2023.

Raffle tickets will cost either \$10.00 or \$20.00 with pre-sales starting Monday, August 14, 2023.

They have requested a waiver of both the License Fee and Manager's Fidelity Bond as indicated in the attached letter. The raffle license application and required documentation is on file in the Administration office for your review.

Please place this item on the agenda for review and approval by the Village Board of Trustees at their Monday, August 7, 2023 Board meeting.

Thank you.

Attachment

covenant  living  
at WINDSOR PARK

July 31, 2023

Bob Mellor  
Village Manager  
Village of Carol Stream  
505 N. Gary Avenue  
Carol Stream, IL 60188

Dear Mr. Mellor,

I am the raffle manager again for the upcoming Windsor Park Annual Benevolent Care Campaign event, which will be a "Grand Reception," to be held at our Carol Stream campus on Sunday August 20<sup>th</sup>, 2023.

I am writing to request a waiver of the fees associated with our raffle application for the fundraising event.

The raffle is an important feature of our major annual charitable event in support of our Benevolent Care Fund. This fund assists residents who have outlived their financial resources – despite careful planning – so they don't need to move out of the community they have come to know and love. This enables Windsor Park to provide peace of mind for our residents and their loved ones as they progress through the years.

Every dollar given, and every dollar saved, helps make the campaign a success. So, we hope the Village will be able, once more, to waive the fee for our raffle.

Please share this request with the Village Trustees.

Many thanks to Village staff and Trustees,



**Kathy Cornell**  
Director of Philanthropy

**Covenant Living at Windsor Park**  
124 Windsor Park Drive, Carol Stream, IL 60188  
**Desk:** 630-510-5572  
**Email:** [kcornell@covliving.org](mailto:kcornell@covliving.org)  
**Website:** [www.covliving.org](http://www.covliving.org)

**Village of Carol Stream  
Schedule of Bills  
For Village Board Approval on AUGUST 07, 2023**

**AGENDA ITEM**  
L-1 8/7/23

<u>Vendor / Description</u>	<u>Amount</u>	<u>Account Number</u>	<u>Account Description</u>	<u>Invoice No.</u>	<u>Purchase Order</u>
<b>ACTION FENCE CONTRACTORS, INC</b>					
PRIVACY FENCE-354 SHAWNEE DR PO-462705	14,670.00	11740000-55486	ROADWAY CAPITAL IMPROVEMEN	33539	20240045
	<u>14,670.00</u>				
<b>AEP ENERGY</b>					
100 DELLA CT 06/07-07/07/23	9.60	01670300-53213	STREET LIGHT ELECTRICITY	3013130378 JUL-2023	
1025 LIES RD 06/15-07/17/23	30.23	01670300-53213	STREET LIGHT ELECTRICITY	3013130446 JUL-2023	
1345 GEORGETOWN 06/19-07/19/23	19.28	01670300-53213	STREET LIGHT ELECTRICITY	3013130390 JUL-2023	
192 YUMA LN 06/16-07/18/23	26.67	01670300-53213	STREET LIGHT ELECTRICITY	3013130479 JUL-2023	
300 BENNETT DR 06/20-07/20/23	1,315.87	01670300-53213	STREET LIGHT ELECTRICITY	3013130367 JUL-2023	
401 TOMAHAWK 06/16-07/18/23	37.19	01670300-53213	STREET LIGHT ELECTRICITY	3013130468 JUL-2023	
403 SIOUX 06/16-07/18/23	22.18	01670300-53213	STREET LIGHT ELECTRICITY	3013130389 JUL-2023	
491 CHEYENNE 06/16-07/18/23	21.90	01670300-53213	STREET LIGHT ELECTRICITY	3013130413 JUL-2023	
512 CANYON TRL 06/16-07/18/23	19.97	01670300-53213	STREET LIGHT ELECTRICITY	3013130402 JUL-2023	
594 NEZ PERCE CT 06/16-07/18/23	19.49	01670300-53213	STREET LIGHT ELECTRICITY	3013130424 JUL-2023	
633 THUNDERBIRD 06/16-07/18/23	76.86	01670300-53213	STREET LIGHT ELECTRICITY	3013130457 JUL-2023	
796 PAWNEE 06/16-07/18/23	52.50	01670300-53213	STREET LIGHT ELECTRICITY	3013130435 JUL-2023	
	<u>1,651.74</u>				
<b>ALEXANDRA WILLIAMS</b>					
CLOTH ALLOW-WILLIAMS 06/02/23	219.99	01660100-53324	UNIFORMS	EXPRESS 06/02/23	
	<u>219.99</u>				
<b>ALEXIS ARAOZ, GIS ANALYST</b>					
GIS CONTRACTOR-AUG 2023	3,928.88	01652800-52257	GIS SYSTEM	0000026	
	<u>3,928.88</u>				
<b>AMERICAN ROAD MAINTENANCE</b>					
ASPHALT REJUVENATOR, PO-462703 PAY #2	-13,819.09	11-21344	RETAINAGE AMERICAN ROAD MAIL	7198	
ASPHALT REJUVENATOR, PO-462703 PAY #2	138,190.90	11740000-55486	ROADWAY CAPITAL IMPROVEMEN	17198	
	<u>124,371.81</u>				

**Village of Carol Stream  
Schedule of Bills  
For Village Board Approval on AUGUST 07, 2023**

<u>Vendor / Description</u>	<u>Amount</u>	<u>Account Number</u>	<u>Account Description</u>	<u>Invoice No.</u>	<u>Purchase Order</u>
<b>ARAMARK UNIFORM &amp; CAREER APPAREL GROUP INC</b>					
FIRST AID SUPPLIES	125.19	01590000-53317	OPERATING SUPPLIES	ORD4-011655	
	<u>125.19</u>				
<b>ARIEL IBARRIENTOS</b>					
CLOTH ALLOW-IBARRIENTOS 07/03/23 ZAPPOS	104.99	01660100-53324	UNIFORMS	ZAPPOS 07/03/23	
	<u>104.99</u>				
<b>ASSOCIATION OF POLICE SOCIAL WORKERS</b>					
2023 DUES-BINDER	50.00	01660100-52234	DUES & SUBSCRIPTIONS	2023 APSS-BINDER	
	<u>50.00</u>				
<b>B &amp; F CONSTRUCTION CODE SERVICES, INC</b>					
BLDG PLAN REV-270 ARMY TR 23-1476-NEWC	1,448.00	01643700-52253	CONSULTANT	62260	
FIRE ALARM REV-720 NORTH 23-1457-FIRE 23-14	375.00	01643700-52253	CONSULTANT	62290	
FIRE SPRINKLER REV-130 WINDSOR PK 23-1426-I	650.00	01643700-52253	CONSULTANT	62269	
FIRE SPRINKLER REV-494 MISSION ST 23-12595-F	1,283.00	01643700-52253	CONSULTANT	62120	
	<u>3,756.00</u>				
<b>BLOOMING COLOR OF ST CHARLES</b>					
FY23 AUDIT COVERS	82.68	01610100-53315	PRINTED MATERIALS	291704	
	<u>82.68</u>				
<b>BLOOMINGDALE TOWNSHIP</b>					
RAFFLE PROCEEDS 2023-BLOOMINGDALE TOWN	280.00	01-24229	CONCERT RAFFLE PROCEEDS	BLOOMING PANTRY 2023	
	<u>280.00</u>				
<b>BRIAN RUDELICH</b>					
IACP CONF-RUDELICH 08/08-08/12/23	375.00	01660100-52223	TRAINING	IACP 2023-RUDELICH	
	<u>375.00</u>				
<b>CAROL STREAM PARK DISTRICT</b>					
PARK PASSES-JUN 2023	60.00	01-24236	BARK PARK MEMBERSHIP	PARK PASSES JUN 2023	
	<u>60.00</u>				

**Village of Carol Stream  
Schedule of Bills  
For Village Board Approval on AUGUST 07, 2023**

<u>Vendor / Description</u>	<u>Amount</u>	<u>Account Number</u>	<u>Account Description</u>	<u>Invoice No.</u>	<u>Purchase Order</u>
<b>CHRISTOPHER B BURKE ENGR LTD</b>					
GERZEVSKE TOWER-REPAIRS, PO-4037 PAY #4	3,842.50	04201600-52253	CONSULTANT	184472	20240027
	<u>3,842.50</u>				
<b>CITY OF WHEATON</b>					
TRAINING-ACTIVE SHOOTER 05/01/23	1,500.00	01660100-52223	TRAINING	16871	
	<u>1,500.00</u>				
<b>COMED</b>					
KUHN RD, RT64 06/16-07/18/23	33.14	01662300-52298	ATLE SERVICE FEE	4202129060 JUL-2023	
MORTON, LIES 06/21-07/21/23	164.54	01670300-53213	STREET LIGHT ELECTRICITY	0815164035 JUL-2023	
	<u>197.68</u>				
<b>CONCENTRA HEALTH SERVICES, INC</b>					
DOT RANDOM SCREENS 06/21/23	325.00	01600000-52225	EMPLOYMENT PHYSICALS	16634957	
	<u>325.00</u>				
<b>CONRAD POLYGRAPH, INC</b>					
POLYGRAPH-2 CANDIDATES	360.00	01510000-52228	PERSONNEL HIRING	5681	
	<u>360.00</u>				
<b>CONSTELLATION NEW ENERGY</b>					
1348 CHARGER CT 06/15-07/17/23 6588293710:	440.61	04101500-53210	ELECTRICITY	7280332-20 JUL-2023	
1N END THORNHILL 06/15-07/17/23 658829774:	71.90	01670300-53213	STREET LIGHT ELECTRICITY	7280332-6 JUL-2023	
301 ANTELOPE 06/16-07/18/23 65887473701	58.09	01670300-53213	STREET LIGHT ELECTRICITY	7280332-11 JUL-2023	
391 FLINT 06/16-07/18/23 65887891301	45.09	01670300-53213	STREET LIGHT ELECTRICITY	7280332-12 JUL-2023	
451 SILVERLEAF 06/16-07/18/23 65887601901	35.01	01670300-53213	STREET LIGHT ELECTRICITY	7280332-1 JUL-2023	
500 GARY AVE 06/16-07/18/23 65887934601	117.01	01670300-53213	STREET LIGHT ELECTRICITY	7280332-5 JUL-2023	
506 CHEROKEE 06/16-07/18/23 65887546801	39.11	01670300-53213	STREET LIGHT ELECTRICITY	7280332-4 JUL-2023	
880 PAPOOSE CT 06/16-07/18/23 65887474001	78.63	01670300-53213	STREET LIGHT ELECTRICITY	7280332-13 JUL-2023	
990 DEARBORN 06/16-07/18/23 65887560401	51.15	01670300-53213	STREET LIGHT ELECTRICITY	7280332-10 JUL-2023	
	<u>936.60</u>				

**Village of Carol Stream  
Schedule of Bills  
For Village Board Approval on AUGUST 07, 2023**

<u>Vendor / Description</u>	<u>Amount</u>	<u>Account Number</u>	<u>Account Description</u>	<u>Invoice No.</u>	<u>Purchase Order</u>
<b>CONTAINER SALES GROUP INC</b>					
STORAGE CONTAINER-EVIDENCE PO-4663174	9,344.00	02385400-53350	SMALL EQUIPMENT EXPENSE	6219	20240037
STORAGE CONTAINER-EVIDENCE PO-4663174	9,344.00	03395000-53350	SMALL EQUIPMENT EXPENSE	6219	20240037
	<b>18,688.00</b>				
<b>CORE &amp; MAIN LP</b>					
6" VALVE	1,112.48	04201600-53317	OPERATING SUPPLIES	T051713	
BRASS	184.36	04201600-53317	OPERATING SUPPLIES	T275690	
EZ TRAP KIT-1.25" +	1,982.18	04201600-53316	TOOLS	T091403	
HYDRANT PARTS	362.52	04201600-53317	OPERATING SUPPLIES	T079178	
	<b>3,641.54</b>				
<b>CRYSTAL MGMT &amp; MAINTENANCE SRV'S CORP</b>					
JANITORIAL SVC-AUG 2023	4,155.00	01680000-52276	JANITORIAL SERVICES	31203	
	<b>4,155.00</b>				
<b>DARREN BOSHART</b>					
IAFCI CONF-BOSHART 08/27-09/01/23	270.00	01660100-52223	TRAINING	IAFCI 2023-BOSHART	
	<b>270.00</b>				
<b>DU COMM</b>					
DISPATCH SVC AUG-OCT 2023	224,479.75	01662700-52245	DUCOMM DISPATCH	18637	
FACILITY COST 08/01-10/31/23	9,578.21	01662700-52245	DUCOMM DISPATCH	18595	
	<b>234,057.96</b>				
<b>DUPAGE CO CHILDRENS CTR</b>					
DUPAGE CTY CHILD CTR-CONTRIBUTE 07/01/23-	4,000.00	01662400-53330	INVESTIGATION FUND	CS0524	
	<b>4,000.00</b>				
<b>DUPAGE WATER COMMISSION</b>					
DWC LOAN PAYMENT	2,942.62	04200100-56491	LOAN INTEREST	12384	
DWC LOAN PAYMENT	49,043.73	04200100-56490	LOAN PRINCIPAL	12384	
	<b>51,986.35</b>				

**Village of Carol Stream  
Schedule of Bills  
For Village Board Approval on AUGUST 07, 2023**

<u>Vendor / Description</u>	<u>Amount</u>	<u>Account Number</u>	<u>Account Description</u>	<u>Invoice No.</u>	<u>Purchase Order</u>
<b>FEECE OIL CO</b>					
DIESEL FUEL	291.28	04101500-53312	PWC DIESEL FUEL	3979356	
DIESEL FUEL	688.48	04201600-53312	PWC DIESEL FUEL	3979356	
DIESEL FUEL	820.88	01670400-53312	PWC DIESEL FUEL	3979356	
DIESEL FUEL	847.36	01670200-53312	PWC DIESEL FUEL	3979356	
	<b>2,648.00</b>				
<b>FOUNTAIN TECHNOLOGIES, LTD</b>					
FOUNTAIN MAINT-JUL 2023	3,570.00	01680000-52219	TC MAINTENANCE	14537	
	<b>3,570.00</b>				
<b>GENUINE PARTS COMPANY INC</b>					
JN PARTS 06/01-06/30/23	104.97	01696200-53317	OPERATING SUPPLIES	11007487 06-30-23	
JN PARTS 06/01-06/30/23	670.30	01696200-53354	PARTS PURCHASED	11007487 06-30-23	
	<b>775.27</b>				
<b>GOVTEMPSUSA LLC</b>					
OFFICE MANAGER-D KALKE 07/02, 07/09/23	3,474.40	01590000-52253	CONSULTANT	4216107	
OFFICE MANAGER-D KALKE 07/16, 07/23/23	3,474.40	01590000-52253	CONSULTANT	4224664	
PROPERTY INSP-E HERZOG 07/02, 07/09/23	975.00	01643700-52253	CONSULTANT	4216108	
PROPERTY INSPECT-HERZOG 07/16, 07/23/23	1,365.00	01643700-52253	CONSULTANT	4224665	
	<b>9,288.80</b>				
<b>GREGORY WALKER</b>					
IACP CONF-WALKER 08/08-08/12/23	353.00	01660100-52223	TRAINING	IACP 2023-WALKER	
	<b>353.00</b>				
<b>IEPA</b>					
ANNUAL NPDES FEE-WRC 07/01/23-06/30/24	30,000.00	04100100-52272	PROPERTY MAINTENANCE	IL0026352 23/24	
	<b>30,000.00</b>				

**Village of Carol Stream  
Schedule of Bills  
For Village Board Approval on AUGUST 07, 2023**

<u>Vendor / Description</u>	<u>Amount</u>	<u>Account Number</u>	<u>Account Description</u>	<u>Invoice No.</u>	<u>Purchase Order</u>
<b>ILLINOIS PHLEBOTOMY SERVICES LLC</b>					
PHLEBOTOMY SVC 06/03, 06/08, 06/20/23	1,275.00	01662700-53317	OPERATING SUPPLIES	1811	
PHLEBOTOMY SVC 06/30/23	425.00	01662700-53317	OPERATING SUPPLIES	1820	
	<u>1,700.00</u>				
<b>ILLINOIS STATE POLICE</b>					
LIVESCAN FEES, 01598-JUN 2023 IL022040L	169.50	01660100-53317	OPERATING SUPPLIES	20230601598	
	<u>169.50</u>				
<b>ILLINOIS STATE POLICE/DIRECTOR</b>					
COURT ORDERED PAYMENT CSPC2201978	600.00	01-24238	IL STATE POLICE ASSET FORFEIT	22MX466-CSPC2201978	
COURT ORDERED PAYMENT CSPC2300306	1,000.00	01-24238	IL STATE POLICE ASSET FORFEIT	23MX84-CSPC2300306	
COURT ORDERED PAYMENT CSPC2301441	800.00	01-24238	IL STATE POLICE ASSET FORFEIT	23MX276-CSPC2301441	
	<u>2,400.00</u>				
<b>INTERFAITH FOOD PANTRY</b>					
RAFFLE PROCEEDS 2023-INTERFAITH	280.00	01-24229	CONCERT RAFFLE PROCEEDS	INTERFAITH 2023	
	<u>280.00</u>				



**Village of Carol Stream  
Schedule of Bills  
For Village Board Approval on AUGUST 07, 2023**

<u>Vendor / Description</u>	<u>Amount</u>	<u>Account Number</u>	<u>Account Description</u>	<u>Invoice No.</u>	<u>Purchase Order</u>
<b>INTERGOVERNMENTAL PERSONNEL BENEFIT COOPERATIVE</b>					
AUG 2023 INSURANCE	866.98	01670500-51111	GROUP INSURANCE	08012023	
AUG 2023 INSURANCE	1,155.93	01670300-51111	GROUP INSURANCE	08012023	
AUG 2023 INSURANCE	1,348.62	04100100-51111	GROUP INSURANCE	08012023	
AUG 2023 INSURANCE	1,444.94	01670200-51111	GROUP INSURANCE	08012023	
AUG 2023 INSURANCE	1,444.94	01670700-51111	GROUP INSURANCE	08012023	
AUG 2023 INSURANCE	1,926.59	04101500-51111	GROUP INSURANCE	08012023	
AUG 2023 INSURANCE	1,926.59	04201400-51111	GROUP INSURANCE	08012023	
AUG 2023 INSURANCE	2,022.91	01670600-51111	GROUP INSURANCE	08012023	
AUG 2023 INSURANCE	2,361.41	01680000-51111	GROUP INSURANCE	08012023	
AUG 2023 INSURANCE	3,264.49	04103100-51111	GROUP INSURANCE	08012023	
AUG 2023 INSURANCE	3,264.49	04203100-51111	GROUP INSURANCE	08012023	
AUG 2023 INSURANCE	3,392.20	01590000-51111	GROUP INSURANCE	08012023	
AUG 2023 INSURANCE	3,758.50	01640100-51111	GROUP INSURANCE	08012023	
AUG 2023 INSURANCE	3,781.07	01652800-51111	GROUP INSURANCE	08012023	
AUG 2023 INSURANCE	4,427.50	01662500-51111	GROUP INSURANCE	08012023	
AUG 2023 INSURANCE	5,391.88	01643700-51111	GROUP INSURANCE	08012023	
AUG 2023 INSURANCE	6,068.78	01670400-51111	GROUP INSURANCE	08012023	
AUG 2023 INSURANCE	6,592.23	01662300-51111	GROUP INSURANCE	08012023	
AUG 2023 INSURANCE	6,743.06	04200100-51111	GROUP INSURANCE	08012023	
AUG 2023 INSURANCE	7,002.12	01610100-51111	GROUP INSURANCE	08012023	
AUG 2023 INSURANCE	7,224.71	01696200-51111	GROUP INSURANCE	08012023	
AUG 2023 INSURANCE	7,321.08	04201600-51111	GROUP INSURANCE	08012023	
AUG 2023 INSURANCE	8,669.70	01670100-51111	GROUP INSURANCE	08012023	
AUG 2023 INSURANCE	10,134.34	01620100-51111	GROUP INSURANCE	08012023	
AUG 2023 INSURANCE	10,480.95	01662600-51111	GROUP INSURANCE	08012023	
AUG 2023 INSURANCE	12,149.15	01662400-51111	GROUP INSURANCE	08012023	
AUG 2023 INSURANCE	15,541.35	01664700-51111	GROUP INSURANCE	08012023	
AUG 2023 INSURANCE	31,261.85	01660100-51111	GROUP INSURANCE	08012023	
AUG 2023 INSURANCE	43,131.45	01600000-51111	GROUP INSURANCE	08012023	
AUG 2023 INSURANCE	77,096.43	01662700-51111	GROUP INSURANCE	08012023	

**Village of Carol Stream  
Schedule of Bills  
For Village Board Approval on AUGUST 07, 2023**

<u>Vendor / Description</u>	<u>Amount</u>	<u>Account Number</u>	<u>Account Description</u>	<u>Invoice No.</u>	<u>Purchase Order</u>
	<u>291,196.24</u>				
<b>IRTH SOLUTIONS LLC</b>					
JULIE SOFTWARE 06/2023-05/2024	875.00	04200100-52234	DUES & SUBSCRIPTIONS	SIN000627	
JULIE SOFTWARE 06/2023-05/2024	875.00	04100100-52234	DUES & SUBSCRIPTIONS	SIN000627	
JULIE SOFTWARE 06/2023-05/2024	1,750.00	01670100-52234	DUES & SUBSCRIPTIONS	SIN000627	
	<u>3,500.00</u>				
<b>ITRON INC</b>					
ITRON MAINT 08/01/23-07/31/24	5,565.12	04103100-52255	SOFTWARE MAINTENANCE	654513	
ITRON MAINT 08/01/23-07/31/24	5,565.13	04203100-52255	SOFTWARE MAINTENANCE	654513	
	<u>11,130.25</u>				
<b>JULIE INC</b>					
JULIE 04/01-06/30/23	332.50	01670600-52272	PROPERTY MAINTENANCE	2023-0278 08/07/23	
JULIE 04/01-06/30/23	332.50	01670300-52272	PROPERTY MAINTENANCE	2023-0278 08/07/23	
JULIE 04/01-06/30/23	332.50	04201600-52272	PROPERTY MAINTENANCE	2023-0278 08/07/23	
JULIE 04/01-06/30/23	332.51	04101500-52272	PROPERTY MAINTENANCE	2023-0278 08/07/23	
	<u>1,330.01</u>				
<b>JETCO LTD</b>					
TOWER 2-PAINT, REPAIRS PO-4042 PAY #1	-28,857.80	04-21241	RETAINAGE JETCO	3408	20240043
TOWER 2-PAINT, REPAIRS PO-4042 PAY #1	288,578.00	04201600-52244	MAINTENANCE & REPAIR	3408	20240043
TOWER 2-PAINT, REPAIRS PO-4042 PAY #2	-18,696.05	04-21241	RETAINAGE JETCO	3410	20240043
TOWER 2-PAINT, REPAIRS PO-4042 PAY #2	186,960.50	04201600-52244	MAINTENANCE & REPAIR	3410	20240043
	<u>427,984.65</u>				
<b>JOHN L FIOTI</b>					
ADJUDICATION-JUL 2023	575.00	01570000-52238	LEGAL FEES	JULY 2023	
	<u>575.00</u>				
<b>KLUBER, INC.</b>					
CONSTR OVERSIGHT PO-4069 PAY #1	6,533.80	11740000-55487	FACILITY CAPITAL IMPROVEMENT 8551		20240044
	<u>6,533.80</u>				

**Village of Carol Stream  
Schedule of Bills  
For Village Board Approval on AUGUST 07, 2023**

<u>Vendor / Description</u>	<u>Amount</u>	<u>Account Number</u>	<u>Account Description</u>	<u>Invoice No.</u>	<u>Purchase Order</u>
<b>LANDSCAPE MATERIAL &amp; FIREWOOD SALES INC</b>					
PARKWAY RESTOS	380.00	01670400-53317	OPERATING SUPPLIES	32625	
RESTORATIONS	220.00	01670400-53317	OPERATING SUPPLIES	33797	
TOP SOIL	270.00	01670400-53317	OPERATING SUPPLIES	33670	
	<u>870.00</u>				
<b>LAW OFFICE OF MICHELLE L MOORE LTD</b>					
PROSECUTION-JUL 2023	2,400.00	01570000-52235	LEGAL FEES-PROSECUTION	2023-7	
PROSECUTION-JUL 2023	7,924.39	01570000-52312	PROSECUTION DUI	2023-7	
	<u>10,324.39</u>				
<b>LRS HOLDINGS LLC</b>					
BASIN MATERIAL	330.00	01670500-52265	HAULING	0005362603	
HAULING CATCH BASIN	1,155.00	01670500-52265	HAULING	LR5381126	
HAULING JUL-2023	1,968.50	01670500-52265	HAULING	LR5392456	
NATIONAL NIGHT OUT 08/01-08/02/23	1,000.00	01664700-53325	COMMUNITY RELATIONS	TBD	
RENTAL-300 KUHN RD 06/02-06/29/23	138.00	01670400-52264	EQUIPMENT RENTAL	PS542461	
STREET SWEEP SVC PO-4041	10,164.06	01670600-52272	PROPERTY MAINTENANCE	PS546847	20240016
	<u>14,755.56</u>				
<b>MARK E RADABAUGH</b>					
TAPING, EDITING 07/17/23	100.00	01590000-52253	CONSULTANT	23-0227	
	<u>100.00</u>				
<b>MID AMERICAN WATER INC</b>					
PW-STORM H2O	1,659.80	01670600-53317	OPERATING SUPPLIES	218051A	
PW-STORM H2O	1,197.00	01670600-53317	OPERATING SUPPLIES	218052A	
STORM SEWER CEMENT	2,124.00	01670600-53317	OPERATING SUPPLIES	218897A	
	<u>4,980.80</u>				
<b>MILTON TOWNSHIP FOOD PANTRY</b>					
RAFFLE PROCEEDS 2023-MILTON TOWNSHIP	280.00	01-24229	CONCERT RAFFLE PROCEEDS	MILTON PANTRY 2023	
	<u>280.00</u>				

**Village of Carol Stream  
Schedule of Bills  
For Village Board Approval on AUGUST 07, 2023**

<u>Vendor / Description</u>	<u>Amount</u>	<u>Account Number</u>	<u>Account Description</u>	<u>Invoice No.</u>	<u>Purchase Order</u>
<b>MNJ TECHNOLOGIES DIRECT</b>					
SOFTWARE MAINT	658.74	01652800-52255	SOFTWARE MAINTENANCE	CINV004010295	
	<u>658.74</u>				
<b>MSDSONLINE INC</b>					
MSDS ONLINE 08/03/23-08/02/24	2,649.00	01652800-52255	SOFTWARE MAINTENANCE	286574	
	<u>2,649.00</u>				
<b>MUNICIPAL CLERKS OF DUPAGE CO</b>					
DUES-J SCHWARZE 06/01/23-06/30/24	20.00	01520000-52234	DUES & SUBSCRIPTIONS	MCDC 2023-SCHWARZE	
	<u>20.00</u>				
<b>MUNICIPAL GIS PARTNERS INC</b>					
MGP GIS-JUL 2023	12,982.50	01652800-52257	GIS SYSTEM	6738	
	<u>12,982.50</u>				
<b>NEENAH FOUNDARY COMPANY</b>					
STORM SEWER	511.00	01670600-53317	OPERATING SUPPLIES	120588	
	<u>511.00</u>				
<b>NEIGHBORHOOD FOOD PANTRIES</b>					
RAFFLE PROCEEDS 2023-NEIGHBORHOOD	280.00	01-24229	CONCERT RAFFLE PROCEEDS	NEIGHBOR PANTRY 2023	
	<u>280.00</u>				
<b>NICOLAS BACIDORE</b>					
IACP-BACIDORE 08/08-08/12/23	375.00	01660100-52223	TRAINING	IACP 2023-BACIDORE	
	<u>375.00</u>				
<b>NICOR</b>					
124 GERZEVSKE LN 06/20-07/20/23	49.88	04201600-53230	NATURAL GAS	13811210007 JUL-2023	
1348 CHARGER CT 06/21-07/21/23	203.09	04101500-53230	NATURAL GAS	8660601178 JUL-2023	
200 TUBEWAY DR 06/19-07/19/23	51.94	04101500-53230	NATURAL GAS	14309470202 JUL-2023	
	<u>304.91</u>				

**Village of Carol Stream  
Schedule of Bills  
For Village Board Approval on AUGUST 07, 2023**

<u>Vendor / Description</u>	<u>Amount</u>	<u>Account Number</u>	<u>Account Description</u>	<u>Invoice No.</u>	<u>Purchase Order</u>
<b>NOTARY PUBLIC ASSOCIATION OF IL</b>					
NOTARY-DOMINGUEZ	59.00	01610100-52234	DUES & SUBSCRIPTIONS	NOTARY 2023-DOMINGUE	
NOTARY-NORTHRUP	59.00	01610100-52234	DUES & SUBSCRIPTIONS	NOTARY 2023-NORTHRUP	
	<u>118.00</u>				
<b>OMI</b>					
WRC CAPEX MAY-JUN 2023 PO-4039 PAY #4	11,485.00	04101100-52262	WRC CONTRACT	351199-CE-33	20240005
	<u>11,485.00</u>				
<b>OPERATION SUPPORT OUR TROOPS</b>					
2023 CONCERT SERIES-OPERATION SUPPORT OU	1,000.00	01-24227	SUPPORT OUR TROOPS RAFFLE	2023 CONTRIBUTION	
	<u>1,000.00</u>				
<b>PAULINA GAJOWNICZEK</b>					
TUITION REIMB-BUS522 06/05-07/29/23	1,482.75	01610100-52223	TRAINING	BUS522	
	<u>1,482.75</u>				
<b>PETTY CASH</b>					
PETTY CASH 08/07/23	828.63	01-10307	PETTY CASH	PETTY CASH 08/07/23	
	<u>828.63</u>				
<b>PHILIP HECK</b>					
IACP CONF-HECK 08/08-08/12/23	375.00	01660100-52223	TRAINING	IACP 2023-HECK	
	<u>375.00</u>				
<b>PHYSICIANS IMMEDIATE CARE-CHICAGO</b>					
POST OFFER PHYSICAL-BINDER 06/07/23	152.00	01600000-52225	EMPLOYMENT PHYSICALS	4336445	
	<u>152.00</u>				
<b>PLOTE CONSTRUCTION INC</b>					
FAIR OAKS IMPROVEMENT 7/31/23 PO-462-701	-45,526.44	06-21112	RETAINAGE - PLOTE	230340.01	
FAIR OAKS IMPROVEMENT 7/31/23 PO-462-701	455,264.37	06320000-54469	REBUILD ILLINOIS BOND	230340.01	
	<u>409,737.93</u>				

**Village of Carol Stream  
Schedule of Bills  
For Village Board Approval on AUGUST 07, 2023**

<u>Vendor / Description</u>	<u>Amount</u>	<u>Account Number</u>	<u>Account Description</u>	<u>Invoice No.</u>	<u>Purchase Order</u>
<b>QUADIENT, INC</b>					
POSTAGE METER LEASE 08/05-11/04/23	541.68	01610100-53317	OPERATING SUPPLIES	N10017255	
	<b>541.68</b>				
<b>QUINN WILLIS</b>					
CLOTH ALLOW-WILLIS 07/14/23	104.93	01660100-53324	UNIFORMS	FASHIONNOVA 07/14/23	
	<b>104.93</b>				
<b>REFUNDS MISC</b>					
23-0584-GZBO, 444 ALEUT TRL-REFUND	48.00	01000000-42307	BUILDING PERMITS	444 ALEUT TRL-2023	
23-1203-RMDR, 912 HIGH RIDGE PASS-REFUND	100.00	01000000-42307	BUILDING PERMITS	912 HIGH RIDGE-2023	
23-1243-FENC, 452 COCHISE CT-REFUND	32.00	01000000-42307	BUILDING PERMITS	452 COCHISE CT-2023	
23-1289-FENC, 619 AZTEC DR-REFUND	64.00	01000000-42307	BUILDING PERMITS	619 AZTEC DR-2023	
23-1451-ACF, 1113 BRADBURY CIR-REFUND	112.00	01000000-42307	BUILDING PERMITS	1113 BRADBURY-2023	
TOW REIMB-CSP23023580	475.00	01000000-45321	TOWING FEE	LUCAS PALANTI-2023	
	<b>831.00</b>				
<b>REFUNDS PRESERVATION BONDS</b>					
23-1360-PFOS, 1164 BROOKSTONE-REFUND	200.00	01-24302	ESCROW - GRADING	1164 BROOKSTONE-2023	
	<b>200.00</b>				
<b>REFUNDS W&amp;S FINALS</b>					
	5.64	04-12110	ACCOUNT RECEIV WATER & SEWER	11096-19774	
	6.53	04-12110	ACCOUNT RECEIV WATER & SEWER	11103-11104	
	11.84	04-12110	ACCOUNT RECEIV WATER & SEWER	11104-15035	
	20.55	04-12110	ACCOUNT RECEIV WATER & SEWER	11102-19298	
	23.45	04-12110	ACCOUNT RECEIV WATER & SEWER	11098-11755	
	29.96	04-12110	ACCOUNT RECEIV WATER & SEWER	11105-20238	
	31.20	04-12110	ACCOUNT RECEIV WATER & SEWER	11099-12187	
	50.56	04-12110	ACCOUNT RECEIV WATER & SEWER	11100-17908	
	65.35	04-12110	ACCOUNT RECEIV WATER & SEWER	11097-11080	
	677.33	04-12110	ACCOUNT RECEIV WATER & SEWER	11101-20385	
	<b>922.41</b>				

**Village of Carol Stream  
Schedule of Bills  
For Village Board Approval on AUGUST 07, 2023**

<u>Vendor / Description</u>	<u>Amount</u>	<u>Account Number</u>	<u>Account Description</u>	<u>Invoice No.</u>	<u>Purchase Order</u>
<b>ROADSAFE TRAFFIC SYSTEMS, INC</b>					
GRAPHICS	546.20	10670000-54415	VEHICLES	177952	
	<u>546.20</u>				
<b>ROMAAS, INC</b>					
RENOVATION-PD PO-4663133 PAY #8	-8,785.00	11740000-55487	FACILITY CAPITAL IMPROVEMENT 2237-8		
RENOVATION-PD PO-4663133 PAY #8	36,948.90	11-21454	RETAINAGE - ROMAAS, INC 2237-8		
	<u>28,163.90</u>				
<b>SAE CUSTOMS INC</b>					
UNIT 636 50% PARTS PO-4663166	6,853.28	01662700-53350	SMALL EQUIPMENT EXPENSE	4401	20240042
UNIT 637 UPFIT PO-4663173 FINAL	7,054.37	01662700-53350	SMALL EQUIPMENT EXPENSE	4457	20240036
UNIT 638 50% PARTS PO-4663169	6,734.53	01662700-53350	SMALL EQUIPMENT EXPENSE	4404	20240041
UNIT 639 50% PARTS PO-4663167	6,734.53	01662700-53350	SMALL EQUIPMENT EXPENSE	4402	20240040
UNIT 642 50% PARTS PO-4663168	7,567.21	01662700-53350	SMALL EQUIPMENT EXPENSE	4403	20240039
UNIT 646 UPFIT PO-4663170 FINAL	7,427.12	01662700-53350	SMALL EQUIPMENT EXPENSE	4460	20240038
	<u>42,371.04</u>				
<b>SARA DUMDIE</b>					
CLOTH ALLOW-DUMDIE	128.00	01660100-53324	UNIFORMS	KOHL'S 07/16/23	
	<u>128.00</u>				
<b>SEALMASTER CHICAGO</b>					
YELLOW CURB PAINT	396.96	01670300-53317	OPERATING SUPPLIES	99696	
	<u>396.96</u>				
<b>SEBERT LANDSCAPING</b>					
IRRIGATION REPAIR-ZONE 6	978.00	11740000-55486	ROADWAY CAPITAL IMPROVEMENT	571227	
	<u>978.00</u>				
<b>STANDARD EQUIPMENT COMPANY</b>					
STORM SEWER INSPECT-POLE CAMERA PO-4078	19,450.00	01670600-53350	SMALL EQUIPMENT EXPENSE	U01161	20240047
	<u>19,450.00</u>				

**Village of Carol Stream  
Schedule of Bills  
For Village Board Approval on AUGUST 07, 2023**

<u>Vendor / Description</u>	<u>Amount</u>	<u>Account Number</u>	<u>Account Description</u>	<u>Invoice No.</u>	<u>Purchase Order</u>
<b>TESTING SERVICE CORP</b>					
CONSTR MATERIALS-TESTING	1,766.00	11740000-55486	ROADWAY CAPITAL IMPROVEMENT	N127593	
	<u>1,766.00</u>				
<b>THIRD MILLENIUM ASSOCIATES INCORPORATED</b>					
BILL PRINTING, S/O POSTAGE 07/28/23	22.36	04203100-52229	POSTAGE	30263	
BILL PRINTING, S/O POSTAGE 07/28/23	22.37	04103100-52229	POSTAGE	30263	
BILL PRINTING, S/O POSTAGE 07/28/23	1,308.73	04203100-52221	UTILITY BILL PROCESSING	30263	
BILL PRINTING, S/O POSTAGE 07/28/23	1,308.74	04103100-52221	UTILITY BILL PROCESSING	30263	
GREEN PAY FEE-JUL 2023	257.35	04103100-52221	UTILITY BILL PROCESSING	30264	
GREEN PAY FEE-JUL 2023	257.36	04203100-52221	UTILITY BILL PROCESSING	30264	
	<u>3,176.91</u>				
<b>TIM'S AUTO BODY</b>					
UNIT 651 REPAIR	1,931.60	01662700-52244	MAINTENANCE & REPAIR	4739	
	<u>1,931.60</u>				
<b>TRANSYSTEMS CORPORATION</b>					
LIES RD-BIKE PATH, PH 3 PO-462693 PAY #5	17,211.79	11740000-55486	ROADWAY CAPITAL IMPROVEMENT	05-4183153	
	<u>17,211.79</u>				
<b>TYCO FIRE &amp; SECURITY (US)MGMT INC</b>					
EMERGENCY REPAIRS-FIRE SYSTEM, KUHN PUMF	2,877.63	04201600-52244	MAINTENANCE & REPAIR	51057702	
	<u>2,877.63</u>				
<b>TYLER TECHNOLOGIES INC</b>					
VH C/C TERMINALS 08/01/23-07/31/24	540.00	01610100-52255	SOFTWARE MAINTENANCE	045-430832	
VH C/C TERMINALS 08/01/23-07/31/24	1,257.00	01610100-53350	SMALL EQUIPMENT EXPENSE	045-430832	
	<u>1,797.00</u>				



**Village of Carol Stream  
Schedule of Bills  
For Village Board Approval on AUGUST 07, 2023**

<u>Vendor / Description</u>	<u>Amount</u>	<u>Account Number</u>	<u>Account Description</u>	<u>Invoice No.</u>	<u>Purchase Order</u>
<b>U S POSTMASTER</b>					
POSTAGE WATER BILLS-JUL 2023	2,723.25	04203100-52229	POSTAGE	1529 07/28/23	
POSTAGE WATER BILLS-JUL 2023	2,723.26	04103100-52229	POSTAGE	1529 07/28/23	
	<u>5,446.51</u>				
<b>USA BLUE BOOK</b>					
HYDRANT METERS	2,139.90	04201400-53333	NEW METERS	INV00063898	
	<u>2,139.90</u>				
<b>VERIZON WIRELESS</b>					
CELL PHONES 06/14-07/13/23	36.01	02385200-52230	TELEPHONE	9939617961	
CELL PHONES 06/14-07/13/23	38.01	01652800-52230	TELEPHONE	9939617961	
CELL PHONES 06/14-07/13/23	42.17	01610100-52230	TELEPHONE	9939617961	
CELL PHONES 06/14-07/13/23	42.17	01640100-52230	TELEPHONE	9939617961	
CELL PHONES 06/14-07/13/23	42.17	01643700-52230	TELEPHONE	9939617961	
CELL PHONES 06/14-07/13/23	44.62	01662700-52230	TELEPHONE	9939617961	
CELL PHONES 06/14-07/13/23	80.18	01600000-52230	TELEPHONE	9939617961	
CELL PHONES 06/14-07/13/23	84.34	01680000-52230	TELEPHONE	9939617961	
CELL PHONES 06/14-07/13/23	96.65	01652800-52230	TELEPHONE	9939617961	
CELL PHONES 06/14-07/13/23	109.28	01643700-52230	TELEPHONE	9939617961	
CELL PHONES 06/14-07/13/23	122.35	01696200-52230	TELEPHONE	9939617961	
CELL PHONES 06/14-07/13/23	171.75	01590000-52230	TELEPHONE	9939617961	
CELL PHONES 06/14-07/13/23	205.11	04100100-52230	TELEPHONE	9939617961	
CELL PHONES 06/14-07/13/23	291.05	01620100-52230	TELEPHONE	9939617961	
CELL PHONES 06/14-07/13/23	356.89	01652800-52230	TELEPHONE	9939617961	
CELL PHONES 06/14-07/13/23	555.10	01670100-52230	TELEPHONE	9939617961	
CELL PHONES 06/14-07/13/23	589.14	04200100-52230	TELEPHONE	9939617961	
CELL PHONES 06/14-07/13/23	2,971.84	01662700-52230	TELEPHONE	9939617961	
	<u>5,878.83</u>				

**Village of Carol Stream  
Schedule of Bills  
For Village Board Approval on AUGUST 07, 2023**

<u>Vendor / Description</u>	<u>Amount</u>	<u>Account Number</u>	<u>Account Description</u>	<u>Invoice No.</u>	<u>Purchase Order</u>
<b>VIKING CHEMICAL COMPANY</b>					
KUHN RD-SODIUM HYPOCHLORITE	336.91	04201600-53331	CHEMICALS	148896	
	<u>336.91</u>				
<b>VILLA PARK OFFICE EQUIPMENT</b>					
FURNITURE PO-4663150 PAY #8	1,079.96	11740000-55487	FACILITY CAPITAL IMPROVEMENT 77785		
	<u>1,079.96</u>				
<b>VILLAGE OF CAROL STREAM</b>					
124 GERZEVSKE LN-E PUMP STATION 06/01-07/0	131.52	04200100-53220	WATER	02037622-21254	
124 GERZEVSKE LN-N GARAGE 06/01-07/03/23	125.99	01670100-53220	WATER	02037292-20874	
124 GERZEVSKE LN-PW CENTER 06/01-07/03/23	145.14	01670100-53220	WATER	02037293-20875	
124 GERZEVSKE LN-PW METER 06/02-07/01/23	6.80	04200100-53220	WATER	02037610-21240	
124 GERZEVSKE LN-WASHDOWN BIN 06/02-07/01/23	329.29	04200100-53220	WATER	02037625-21257	
245 KUHN RD-ADMIN BLDG 06/01-07/03/23	28.79	04101500-53220	WATER	02037290-20872	
245 KUHN RD-BLOWER BLDG I 06/01-07/03/23	36.49	04101500-53220	WATER	02037647-21279	
245 KUHN RD-BLOWER BLDG II 06/01-07/03/23	0.73	04101500-53220	WATER	02037646-21278	
245 KUHN RD-MAINT CONTROL BLDG 06/01-07/03/23	5.37	04101500-53220	WATER	02037289-20871	
245 KUHN RD-SLUDGE 06/01-07/03/23	567.11	04101500-53220	WATER	02037660-21292	
246 KUHN RD-BTH MAINT BLDG 06/01-07/03/23	3.96	04101500-53220	WATER	02037624-21256	
300 KUHN RD-CHLORINE ANALYZER 06/01-07/03/23	8.01	04200100-53220	WATER	02037623-21255	
300 KUHN RD-RESERVOIR 06/01-07/03/23	24.53	04200100-53220	WATER	02037658-21290	
301 LIES RD-FARMHOUSE 06/01-07/03/23	0.27	01680000-53220	WATER	02035434-18979	
500 GARY AVE-VH 06/01-07/03/23	660.88	01680000-53220	WATER	02037294-20876	
960 GARY AVE-FOUNTAIN 06/01-07/03/23	1,262.83	01680000-53220	WATER	02037295-20877	
960 GARY AVE-VISITOR CTR 06/01-07/03/23	358.50	01680000-53220	WATER	02037296-20878	
	<u>3,696.21</u>				
<b>WAYNE TOWNSHIP FOOD PANTRY</b>					
RAFFLE PROCEEDS 2023-WAYNE TOWNSHIP	280.00	01-24229	CONCERT RAFFLE PROCEEDS	WAYNE PANTRY 2023	
	<u>280.00</u>				

**Village of Carol Stream  
Schedule of Bills  
For Village Board Approval on AUGUST 07, 2023**

<u>Vendor / Description</u>	<u>Amount</u>	<u>Account Number</u>	<u>Account Description</u>	<u>Invoice No.</u>	<u>Purchase Order</u>
<b>WINDY CITY CLEANING EQUIP &amp; SUPPLIES</b>					
JN HOSE FITTING	77.99	01696200-53354	PARTS PURCHASED	005442	
	<u>77.99</u>				
<b>GRAND TOTAL</b>	<b><u><u>\$1,883,674.00</u></u></b>				

**The preceding list of bills payable totaling \$ 1,883,674.00 was reviewed and approved for payment.**

**Approved by:**

Robert Mellor  
Bob Mellor - Village Manager

**Date:** 8/4/23

**Authorized by:**

\_\_\_\_\_  
Frank Saverino Sr-Mayor

\_\_\_\_\_  
Julia Schwarze- Village Clerk

**ADDENDUM WARRANTS  
 JULY 18, 2023 Thru AUGUST 07, 2023**

Fund	Check #	Vendor	Description	Amount
General	A C H	Wheaton Bank & Trust	Payroll July 10, 2023 thru July 23, 2023	654,679.17
Water & Sewer	A C H	Wheaton Bank & Trust	Payroll July 10, 2023 thru July 23, 2023	56,084.57
				710,763.74

Approved this \_\_\_\_\_ day of \_\_\_\_\_, 2023

By: \_\_\_\_\_  
 Frank Saverino Sr-Mayor

\_\_\_\_\_  
 Julia Schwarze - Village Clerk