

Village of Carol Stream

BOARD MEETING

AGENDA

MARCH 7, 2016

7:30 P.M.

All matters on the Agenda may be discussed, amended and acted upon

A. ROLL CALL AND PLEDGE OF ALLEGIANCE:

B. MINUTES:

1. Approval of Minutes of the February 16, 2016 Special Workshop Meeting
2. Approval of Minutes of the February 16, 2016 Village Board Meeting.

C. LISTENING POST:

1. Resolution No. 2853 Recognizing Ed Sailer for Thirty Years of Service with the Village of Carol Stream.
2. Proclamation Celebrating 2016 Earth Hour.
3. Addresses from Audience (3 Minutes).

D. PUBLIC HEARINGS:

E. SELECTION OF CONSENT AGENDA:

If you are here for an item which is added to the consent agenda and approved, the Village Board has acted favorably on your request.

F. BOARD AND COMMISSION REPORTS:

1. PLAN COMMISSION:

- a. #15342 – Dunkin’ Donuts, 222 W. Army Trail Road
*Special Use Permit - Drive-up Service Window
Amendment to an Approved Planned Unit Development Plan*
RECOMMENDED APPROVAL SUBJECT TO CONDITIONS 6-0
- b. #15365–27W245 North Avenue LLC (AT&T), 27W245 North Ave.
*Zoning Map Amendment to B-3 Service District (upon annexation)
Zoning Code Variation-Building Setback*
CONTINUED TO MARCH 28, 2016 6-0
- c. #16013-Village of Carol Stream-500 N. Gary Avenue
2016 Zoning Map
APPROVED 6-0

Village of Carol Stream

BOARD MEETING

AGENDA

MARCH 7, 2016

7:30 P.M.

All matters on the Agenda may be discussed, amended and acted upon

G. OLD BUSINESS:

H. STAFF REPORTS AND RECOMMENDATIONS:

1. Waiver of Formal Bidding & Award of Contract-Farmhouse Exterior Renovation. *This project to replace existing siding, soffit, fascia, windows and pediments was previously formally bid with one qualified bidder responding to the published Notice to Bid. The Village Board rejected all bids and directed staff to negotiate a contract for the exterior renovation of the farmhouse at its Board meeting on February 15, 2016. Staff is recommending waiving the formal bidding process and awarding the contract for exterior renovation of the farmhouse located at 301 W. Lies Road to DuPree Construction Co. in the amount of \$58,637.80.*
2. Motion to Approve Extension of Trees Removal Contract – 1-800 Tree Guy. *Staff recommends the Board award a contract extension to 1-800 Tree Guy for tree removal services at an amount not to exceed \$37,500 for the period of May 1, 2016 through April 30, 2017.*
3. Fourth of July Parade Donation. *Payment of resident donations in the amount of \$1,893.49 to the 4th of July Parade Committee for their 2016 July 4th Parade.*
4. Recommendation for Purchase of Dump Truck. *Staff is recommending replacement of a large dump truck #65 and purchase of a Peterbilt Model 348 from JX Peterbilt through Lake County DOT contract #15015 in the amount of \$180,917.96 to be painted a custom pink color in recognition of breast cancer awareness through voluntary commitments from various suppliers and vendors who want to support efforts to increase breast cancer awareness.*
5. Motion to enter into an Engineering Services Agreement for the Water Reclamation Center (WRC) NPDES Permit Assistance with Baxter & Woodman, Inc. *Staff recommends entering into an Engineering Services Agreement with Baxter and Woodman, Inc. for WRC NPDES Permit Assistance in an amount not to exceed \$130,400.00 over the next three fiscal years.*

Village of Carol Stream

BOARD MEETING

AGENDA

MARCH 7, 2016

7:30 P.M.

All matters on the Agenda may be discussed, amended and acted upon

I. ORDINANCES:

1. Ordinance No. ____ Approving a Special Use Permit for a Drive-Up Service Window and an Amendment to an Approved Special Use Permit for a Planned Unit Development (Hitesh Patel, Dunkin' Donuts, 222 W. Army Trail Road). *This request was recommended for approval subject to conditions by the Plan Commission/Zoning Board of Appeals on February 22, 2016.*
2. Ordinance No. ____ Amending Chapter 11, Article 2 of the Carol Stream Code of Ordinances by Decreasing the Number of Class A Liquor Licenses from 10 to 9 (Spectator's Pub & Grill, Inc. d/b/a Spectator's Pub & Grill, 552 N. Gary Ave.) and Increasing the Number of Class A Liquor Licenses from 9 to 10 (Chrissy's LLC d/b/a Chrissy's, 552 N. Gary Ave. *A change in ownership for the business located at 552 N. Gary Avenue consists of the following: Spectator's Pub & Grill, Inc. has relinquished their Class A Liquor License and Chrissy's LLC has requested a Class A Liquor License effective May 1, 2016.*
3. Ordinance No. ____ Amending Chapter 11, Article 2 of the Carol Stream Code of Ordinances by Decreasing the Number of Class C Liquor Licenses from 20 to 19 (Jill & Alisha Inc. d/b/a Carol Stream Food Mart, 257 W. Elk Trail) and Increasing the Number of Class C Liquor Licenses from 19 to 20 (Gita Corporation d/b/a Carol Stream Food Mart, 257 W. Elk Trail). *A change in ownership for the business located at 257 W. Elk Trail consists of the following: Jill & Alisha Inc. has relinquished their Class C Liquor License and Gita Corporation has requested a Class C Liquor License effective May 1, 2016.*

J. RESOLUTIONS:

1. Resolution No. ____ Declaring Surplus Property owned by the Village of Carol Stream. *Public Works Department has identified the following equipment: set of 4 hubcaps; idler pulley and bracket; 2 metal cabinets and misc. electronics as surplus and recommends they go to auction or be disposed of.*
2. Resolution No. ____ Declaring Surplus Property owned by the Village of Carol Stream. *Police Department has identified a 2003 Ford Crown*

Village of Carol Stream

BOARD MEETING

AGENDA

MARCH 7, 2016

7:30 P.M.

All matters on the Agenda may be discussed, amended and acted upon

Victoria as surplus due to the vehicle's age, mechanical problems, high mileage and poor body work and recommends the vehicle go to the America's Auto Auction Inc.

3. Resolution No. ____ Accepting a Grant of a Water Main Easement- Angel Associates, LP, 381 E. St. Charles Road. *Approval of the Grant of Water Main Easement for Angel Associates, LP located at 381 E. St. Charles Road is necessary for the Schmale and St. Charles Road Water Main Project.*
4. Resolution No. ____ Authorizing Participation in the 2016 ComEd Green Region Program for the WRC Native Prairie Restoration Project. *Approval of the ComEd Green Region Grant Funds for the WRC Native Prairie Restoration Project would cover a portion of the expenses associated with the landscape on the east side of the WRC.*
5. Resolution No. ____ Authorizing the Execution of the Official Zoning Map of the Village of Carol Stream. *The Village Code of Ordinances requires an annual update of the Zoning Map. The Plan Commission/Zoning Board of Appeals unanimously recommended approval of the 2016 Zoning Map on February 22, 2016.*

K. NEW BUSINESS:

1. Carol Stream Historical Society – Raffle License. *The Carol Stream Historical Society is requesting a raffle license approval and fee waiver for their Family Day at the Farmhouse and Quilt Raffle Drawing to be held on Saturday, September 10, 2016.*
2. Corpus Christi Catholic Church – Raffle License. *Corpus Christi Catholic Church is requesting a raffle license approval and waiver of the fee and Manager's Fidelity Bond for their St. Joseph's Table raffle to be held on Saturday, March 12, 2016.*
3. Longfellow Elementary School PTA – Raffle License. *Longfellow Elementary School PTA is requesting a raffle license approval and waiver of the fee and Manager's Fidelity Bond for their fundraising raffle to be held at the American Legion Hall #76 on Saturday, March 19, 2016.*

Village of Carol Stream

BOARD MEETING

AGENDA

MARCH 7, 2016

7:30 P.M.

All matters on the Agenda may be discussed, amended and acted upon

L. PAYMENT OF BILLS:

1. Regular Bills: February 17, 2016 through March 7, 2016.
2. Addendum Warrants: February 17, 2016 through March 7, 2016.

M. REPORT OF OFFICERS:

1. Mayor:
2. Trustees:
3. Clerk:

N. EXECUTIVE SESSION:

1. Collective Negotiating Matters
2. Pending Litigation
3. Salary Schedules for one or more Classes of Municipal Employees

O. NEW BUSINESS:

1. Consent Decree-Village of Carol Stream v. Carolshire Commons Condominium Association. *Consideration of a consent decree addressing remediation of Property Maintenance Code violations in common (public) areas at Carolshire Commons Condominiums located on the northwest corner of Gary Avenue and Elk Trail.*

P. ADJOURNMENT:

LAST ORDINANCE 2016-02-10 LAST RESOLUTION 2852

NEXT ORDINANCE 2016-03-11 NEXT RESOLUTION 2853

Village of Carol Stream

Special Meeting of the Village Board

CIP Budget Presentation FY 2016-2017 – Part 2

General Fund Budget FY 2016-2017

Gregory J. Bielawski Municipal Center
500 N. Gary Avenue, Carol Stream, IL 60188

February 16, 2016

6:00 p.m. – 7:26 p.m.

Meeting Notes

ATTENDANCE:

Mayor Frank Saverino, Sr.
Trustee Dave Hennessey
Trustee John LaRocca
Trustee Rick Gieser
Trustee Mary Frusolone
Trustee Greg Schwarze
Trustee Matt McCarthy
Village Clerk Laura Czarnecki

Joseph E. Breinig, Village Manager
Bob Mellor, Assistant Village Manager
Chris Oakley, Asst. to the Village Manager
John Batek, Finance Director
Jim Knudsen, Director of Engineering
Phil Modaff, Director of Public Works
Ed Sailer, Police Chief
Don Bastian, Community Dev. Dir.
Caryl Rebholz, Employee Relations Dir.
Marc Talavera, Information Systems Dir.
Dan Hoffman, Deputy Police Chief
John Jungers, Deputy Police Chief
Mike Zochert, Police Commander
Jeff Degnan, Police Commander
Ron Roehn, Supt. of Operations
Jason Pauling, Street Supervisor
Tia Messino, Management Analyst

The meeting was called to order at 6:00 p.m. by Mayor Frank Saverino, Sr. and the roll call read by Village Clerk Laura Czarnecki. The result of the roll call vote was as follows:

Present: Mayor Saverino, Sr., Trustees Hennessey, LaRocca, Gieser, Frusolone, Schwarze and McCarthy

Absent:

Capital Improvement Plan Budget Presentation FY 2016-2017 – Part 2

Village Engineer Knudsen continued reviewing the 2016-17 Capital Improvement Plan starting on page 53 as follows:

Capital Improvement Program – Water & Sewer Projects

WRC Dewatering System Improvement Project
WRC Secondary Clarifier Improvement Project
WRC Grit/Screening Building Roof Replacement Project
WRC Blower Building #2 Roof Replacement Project
Schmale Road Water Main Replacement Project
Water System Studies
Water System Improvements Projects
Water Main Replacement Program Projects
Water Main Condition Assessments Project
Aztec Drive Sanitary Sewer Repairs & Lining Project
North Avenue Sanitary Sewer Rehabilitation Project
SW Reservoir & Pumping Station Project
SW DPWC Connection & Metering Station Project
Force Main Condition Assessments Project
Trunk Sanitary Sewer Condition Assessments Project
Sanitary Sewer System Evaluation Study (SSES)
Sanitary Sewer I&I Reduction Program Projects

Capital Improvement Program – Storm Water Projects

Roadway Drainage Improvements Project
Tubeway & Westgate Stormwater Study
Flood Plain Structure Buyout Program Project
Kehoe Boulevard Stream Bank Stabilization Project
Klein Creek Section 1 Stream Bank Stabilization Project

Capital Improvement Program – Facility Projects

Village Hall Rehabilitation Project
Police Evidence Storage Building Project
PWC Fuel Island Replacement Project
PWC Storage Yard Improvement Project
Town Center Fountain Electrical Improvements Project

Requested but not Programmed – Project Listing

Roadways

Estimated Cost

- | | |
|--|---------------------------|
| 1. Morton Road Phase I Reconstruction | \$2,040,000 |
| 2. Morton Road Bike Path | \$2,430,000 |
| 3. Sidewalk Improvements | \$416,000 |
| 4. Industrial Park Sidewalks | Yet To Be Determined |
| 5. Spring Valley Parking Lot Additions | \$2,000-\$4,000 Per Space |
| 6. Asset Extractions | \$30,000 |

Water and Sewer Utilities

Estimated Cost

- | | |
|---|-------------|
| 1. Wayne Township Water Main Extensions | \$9,000,000 |
| 2. Sanitary Force Main Replacements | \$414,000 |

Stormwater Utilities

Estimated Cost

- | | |
|--|----------------------|
| 1. Klein Creek Flood Forecast Warning System | \$39,000 |
| 2. Carol Stream Venture Flood Control | \$258,000 |
| 3. Southeast Storm Water System Improvements | Yet To Be Determined |
| 4. Tubeway Detention Basin Rehabilitation & Improvements | Yet To Be Determined |
| 5. Fullerton & Kimberly Stormwater Study | \$13,000 |
| 6. Fullerton & Kimberly Storm Water System Improvements | Yet To Be Determined |
| 7. Flood Plain Structure Buyout Lot Enhancement Program | \$786,000 |
| 8. Flood Plain Structure Flood Proofing Program | \$2,900,000 |
| 9. Stormwater Management Facility (SWMF) Retrofitting Program | \$2M Per Facility |
| 10. TMDL Stream Restoration Program (Klein & Thunderbird Creeks) | Yet To Be Determined |
| 11. Pond Shoreline Restoration | Yet To Be Determined |

Facilities

Estimated Cost

- | | |
|--------------------------------|----------------------|
| 1. Community Park Improvements | Yet To Be Determined |
|--------------------------------|----------------------|

General Fund Budget FY 2016-2017

Finance Director Jon Batek reviewed the General Corporate Fund Fiscal Year 2016-2017 Budget as follows:

Proposed FY16/17 - General Fund Budget

FY16/17 BUDGET SUMMARY

Current Year FY15/16 Projected Surplus

Estimated Revenues	\$ 27,416,000	8.2% growth over FY14/15
Estimated Expenditures	22,978,528	7.4% below budget
Projected Surplus	\$ 4,437,472	(transfer to capital per policy)

FY16/17 Budget is Balanced as Proposed

Projected Revenues	\$ 27,900,000	1.8% growth over FY15/16
Proposed Expenditures	25,704,500	
Budgeted Surplus	\$ 2,195,500	(transfer to capital per policy)

Revenues show continued steady growth.

- 8.2% growth estimated in FY15/16 vs FY14/15 actual revenues.
- 1.8% growth projected for FY16/17 vs FY15/16 estimated revenues.

Total proposed FY16/17 expenditures increase by 3.5% over FY15/16 Budget.

- Net proposed addition of 5.80 FTE new employee positions.
- **Focus on Village Board Objectives/Goals from Oct. 2015 Planning Exercise.**

1	Adequate Staffing	5	Branding / Public Relations
2	Revenues	6	Technology
3	Addressing FY15/16 Freezes	7	Infrastructure
4	Economic Development		

3 Year Financial Plan shows sustainability.

FY16/17	\$2.2 M Surplus
FY17/18	\$2.5 M Surplus
FY18/19	\$3.6 M Surplus

Proposed General Corporate Fund Expenditures by Type Fiscal Year 16/17 Beginning May 1, 2016

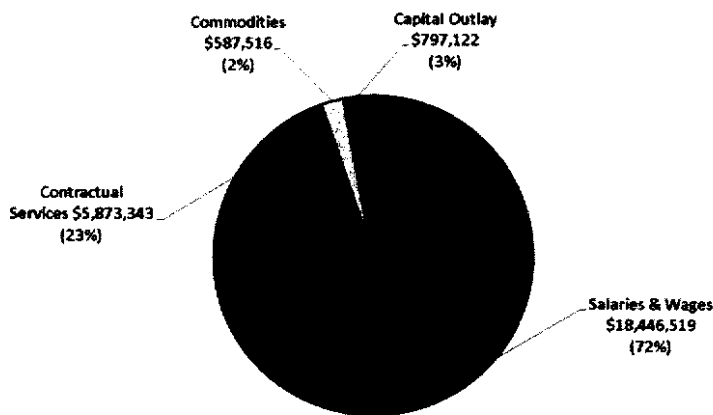

Total Proposed = \$25,704,500

Draft General Corporate Fund Budget Expenditures FY16/17 Proposed Compared to FY15/16 Adopted

	Actual FY14/15	Adopted Budget FY15/16	Estimated FY15/16	Proposed Budget FY16/17	FY16/17 proposed to FY15/16 Budget	
Salaries & Wages						
Personal Services	\$ 10,751,863	\$ 11,149,393	\$ 10,581,701	\$ 11,812,942	663,549	6.0%
Overtime	813,737	846,300	869,500	889,650	43,350	5.1%
Group Insurance	1,585,810	1,628,012	1,546,611	1,840,602	212,590	13.1%
IMRF	754,243	729,414	703,601	852,063	122,649	16.8%
FICA	830,093	848,301	826,369	894,995	46,694	5.5%
WC/Unemp. Ins.	357,565	363,132	339,387	323,132	(40,000)	-11.0%
Police Pension	1,651,830	1,705,946	1,705,946	1,833,135	127,189	7.5%
Total Salaries & Wages	16,745,141	17,270,498	16,573,115	18,446,519	1,176,021	6.8%
Contractual Services	4,741,764	5,573,875	4,963,017	5,873,343	299,468	5.4%
Commodities	567,154	528,377	502,883	587,516	59,139	11.2%
Capital Outlay	441,447	1,454,250	939,513	797,122	(657,128)	-45.2%
Total	\$ 22,495,506	\$ 24,827,000	\$ 22,978,528	\$ 25,704,500	\$ 877,500	3.5%
Other - Transfer to Capital	\$ 2,100,000	\$ 855,000	\$ 4,437,472	\$ 2,195,500		

**Proposed Regular Employee Staffing By Department
Fiscal Year 16/17 Beginning May 1, 2016**

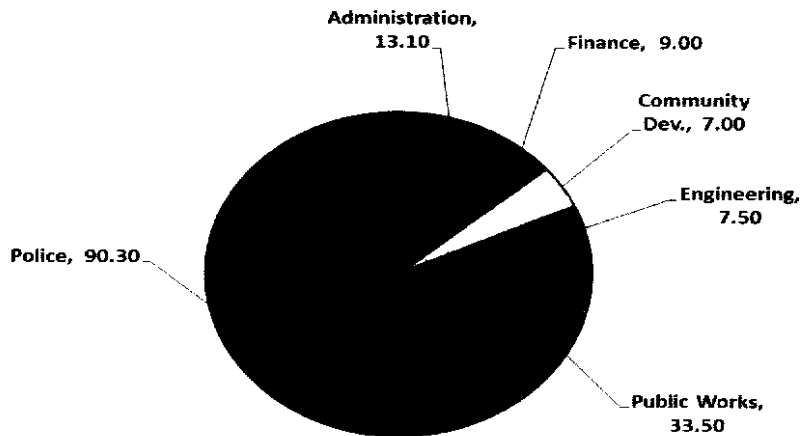

Administration includes Village Manager's Office, Information Technology, Municipal Building, Employee Relations and Village Clerk.

**Changes in Proposed Village Staffing
Current Year FY 15/16**

FY15/16 Authorized Positions - Start of Year 153.60

8/3/15: Village Board Resolution 2820

Public Works

- Delete Asst. Superintendent of Operations (1.00)
- Delete PT Mechanic Helper (0.50)
- + Add: Street Supervisor 1.00
- + Add: Utilities Supervisor 1.00

10/5/15: Village Board Resolution 2831

Community Development

- Delete Asst. Community Development Dir. (1.00)
- Delete PT Development Services Tech. (0.50)
- + Add: Planning & Economic Development Mgr. 1.00
- + Add: Development Services Manager 1.00

11/2/15: Village Board Agenda Item H-8

Information Technology

- Delete 2 PT Information Technology Techs. (1.00)
- + Add: One FT Information Technology Tech. 1.00

FY15/16 Authorized Positions - Current 154.60

Net Change from Beginning of Year 1.00

**Changes in Proposed Village Staffing
Next Year FY 16/17**

FY15/16 Authorized Positions 154.60

Information Technology

- + Information Technology Engineer 1.00

Employee Relations

- + Employee Relations Generalist 1.00
- One PT Secretary (0.40)
- + One PT Secretary from 18 to 25 hours per week 0.20

Engineering Services

- + Stormwater Administrator 1.00

Public Works

- + W/S Fund Employee (title forthcoming) 1.00

+ Mechanic	1.00
Police Department	
+ Police Officer	1.00
Proposed FY16/17 Authorized Staffing	160.40
Net Change from FY15/16	5.80
% Change from FY15/16	3.8%

**History of Budgeted Regular Village Staffing
Fiscal Year 2008/09 though FY2016/17 Proposed**

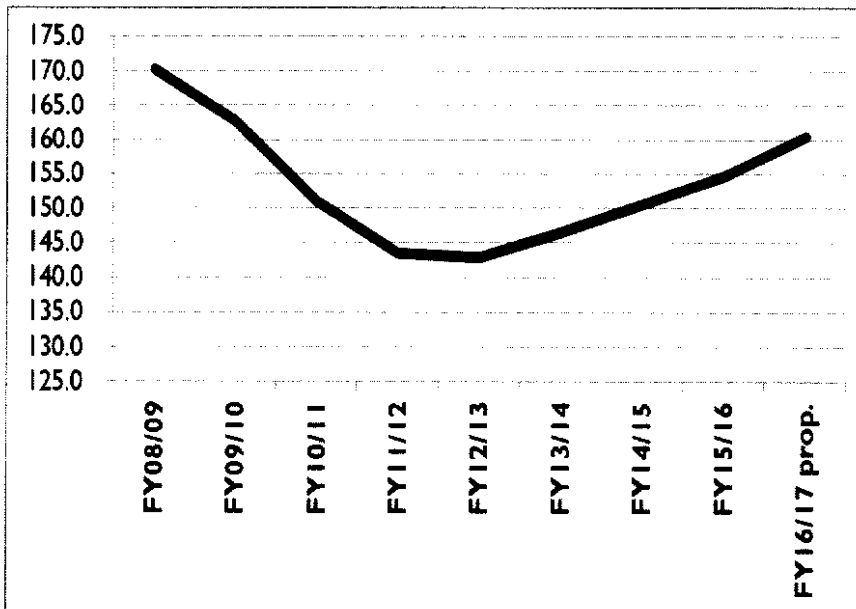

**Proposed FY16/17
General Fund Budget
DEPARTMENT HIGHLIGHTS**

Administration

- Legislative Board
 - CATV/PEG Expense (\$34,000) to account for use of PEG fees. Board Room A/V room Upgrades.
- Legal Services
 - Labor contract renewals in process.
- Village Clerk
- Administration
- Municipal Building
 - Fountain Repairs/Safety Upgrades
 - Village Hall Remodel
 - Preliminary condition and space study assessment completed in FY15/16.

- To be budgeted in Capital Projects Fund in FY16/17 and beyond.
- Town Center
 - Continued level of Thursday concert programming.
 - 4th of July Fireworks contribution.

Information Technology

Technology deployment and advancement is a Village Board goal.

- New IT Network Engineer position proposed to manage significant projects/goals/initiatives.
- Village website redesign – 2 yr. phased project.
- Agenda management software and paperless agendas.
- All GIS program services centrally located under IT function.
- Mondopad.
- Net Motion Mobile VPN.
- Desktop/Laptop replacements.
- Security Camera Upgrades (Village Hall, PWC and Town Center)

Employee Relations

- Proposed increase in employee FTEs of 0.8 for a revised department total of 2.6 FTE.
- Leadership Development Initiative.
- Consultant Review – Exempt Classifications
- Wellness program expansion.

Financial Management

- Implementation of integrated accounts receivable system.
- Banking services / credit card processing costs.

Engineering Services

- Newly proposed Stormwater Administrator position.
- Continued focus on Village infrastructure needs and key role in developing future GIS functionality.
- Implement asset and operations management software solution.

Community Development

- Implementation of new software solution for the Development Services and Code Enforcement programs that will improve efficiency, enhance tracking and reporting capabilities.
- Begin process of digitizing old microfiche/film files and import into document imaging product.
- Economic Development initiatives.

Police Department

- 1 New Police Officer Proposed for FY16/17
 - 2 additional sworn positions proposed in year's 2 and 3 of the proposed financial plan.
- Significant focus on training.
- Report writing software replacement (FY17/18)
- What's not included:
 - Potential DuComm Second Facility Costs
 - Body Cameras

Transfers & Agreements

- Zones rebates enter year 5 of 10.
- Sales tax transfers (50%) to North/Schmale TIF enter year 3 of 13.

- Transfers from Geneva Crossing sales should finish up in FY16/17 and related closing of the TIF by 12/31/16.

Public Works Department

Staffing Plan

- FY15/16
 - Board approved Street Supv. and Utilities Supv.
- FY16/17
 - W/S employee dedicated to water plant and lift station operations (maintenance position)
 - Add Mechanic (maintenance position) – restores pre-recession staffing level (3 Mechanics/1 Supervisor)
- FY17/18
 - Add Facilities Maintenance Technician (maintenance position)
- Snow & Ice
 - Review results - Pilot Program (Spring 2016)
 - Replace one large dump truck (with a twist...)
 - Truck #65 – 28 year-old 2.5-ton dump truck assigned to anti-icing for several years.

A Pink Dump Truck?

- Pink plow, cab and sideboards in recognition of Breast Cancer Awareness
- Feature at public events (Relay for Life, July 4th, WRC Open House)
- Solicit donations by offering a chance to sign the pink area.
- Signs & Lights
 - Entry signage:
 - Repair lighting, repair stone work and clean surfaces of existing signs on North Avenue and south Gary Avenue
 - Design and install new entry signage (\$50,000) at 8 – 9 locations (Village Board Goal)
- Parkway Trees
 - Less than 100 Ash trees remain in inventory
 - Close down the EAB reserve
 - Celebrate the Village's accomplishment!
 - Plant 300 replacement trees (100 spring/200 fall)
- Municipal Garage
 - Fueling system – buy retail?

Trustee McCarthy would like staff to look into a safe trading zone similar to what the Village of Hanover Park does for ebay transactions at the Police Department/Village Hall.

Trustee Schwarze suggested the Village Board donate \$8,400 to the DuPage Senior Center.

Mayor Saverino stated the State of Illinois still does not have a budget and he is concerned that the State of Illinois may still sweep municipally shared revenues.

Staff directed to budget \$10,000 in the FY 2017 budget for the DuPage Senior Center Meals on Wheels Program and pay out \$2,500 each quarter pending passage of State budget.

Village Manager Breinig stated the budget addresses the Village Board staffing goal in a measured way and embodies the economic development, budget freezes, branding/public relations, technical and infrastructure goals.

There being no further business, Trustee LaRocca moved and Trustee Gieser made the second to adjourn the Special Board meeting. The meeting was adjourned unanimously at 7:24 p.m.

FOR THE BOARD OF TRUSTEES

Frank Saverino, Sr, Mayor

ATTEST:

Laura Czarnecki, Village Clerk

REGULAR MEETING OF THE MAYOR AND BOARD OF TRUSTEES
Gregory J. Bielawski Municipal Center, Carol Stream, DuPage County, IL

February 16, 2016

Mayor Saverino, Sr. called the Regular Meeting of the Board of Trustees to order at 7:30 p.m. and directed Village Clerk Laura Czarnecki to call the roll.

Present: Mayor Frank Saverino, Sr. and Trustees David Hennessey, John LaRocca, Rick Gieser, Mary Frusolone, Greg Schwarze and Matt McCarthy

Absent:

Also Present: Village Manager Joe Breinig, Assistant Village Manager Bob Mellor, Village Clerk Laura Czarnecki and Village Attorney Jim Rhodes

*All persons physically present at meeting unless noted otherwise
Trustee Greg Schwarze left at 8:41 p.m.

Mayor Saverino, Sr. led those in attendance in the pledge of allegiance.

MINUTES:

Trustee McCarthy moved and Trustee Frusolone made the second to approve the Minutes of the February 1, 2016 Special Workshop Meeting of the Village Board. The results of the roll call vote were as follows:

Ayes: 6 Trustees Hennessey, LaRocca, Gieser, Frusolone, Schwarze and McCarthy

Abstain: 0

Absent: 0

The motion passed.

Trustee LaRocca moved and Trustee Gieser made the second to approve the Minutes of the February 1, 2016 Regular Board Meeting of the Village Board. The results of the roll call vote were as follows:

Ayes: 6 Trustees Hennessey, LaRocca, Gieser, Frusolone, Schwarze and McCarthy

Abstain: 0

Absent: 0

The motion passed.

Trustee McCarthy moved and Trustee Schwarze made the second to approve, but not release the Minutes of the February 1, 2016 Executive Session Meeting of the Village Board. The results of the roll call vote were as follows:

Ayes: 6 Trustees Hennessey, LaRocca, Gieser, Frusolone,
Schwarze and McCarthy

Abstain: 0

Absent: 0

The motion passed.

LISTENING POST:

1. Year of the Business Spotlight: Angelo Caputo's Fresh Markets- Robertino Presta, CEO. *Trustee Gieser introduced Robertino Presta, Jr., General Manager of Angelo Caputo's Fresh Market on North Avenue who described the operations and history of the store.*
2. APWA 2016 Public Works Project of the Year Award – Klein Creek Flood Mitigation Project. *DuPage County District 6 Board Member and Stormwater Chairman Jim Zay presented the APWA award to the Village.*
3. Addresses from Audience (3 Minutes).

Listed below are tenants and/or landlords of Carolshire that spoke during the Listening Post and/or attended this meeting with regard to Carolshire:

Sunil Jain, Jocelyn Morales, Rosa Martinez, Irvin Romain, Mihail Garbis, Adela Juarez, Stanley Bluit, Deanna McKinney, Lusle Asim, Jamal Khan, Tim Knitto, Frank Banyan, Parvinder Sethi, Dilbagh Singh, Sukhuinder Singh, Juliet Tran, Aziz Khan, Ryan Cornwall, Charlotte Cornwall

Approximately 45 representatives of the Carolshire Commons Condominiums requested help from the Village of Carol Stream regarding inappropriate actions of their Board of Directors. They support the remediation agreement to address code violations, but need help addressing issues with their Board. Things have gone from bad to worse with the current management and mismanagement of funds. The Village Board applauded the residents of Carolshire Commons Condominium Association for coming to the Village with their issues. The residents requested a list of all and outstanding code violations.

PUBLIC HEARINGS:

CONSENT AGENDA:

Trustee McCarthy moved and Trustee Hennessey made the second to establish a Consent Agenda for this meeting. The results of the roll call vote were as follows:

Ayes: 6 Trustees Hennessey, LaRocca, Gieser, Frusolone, Schwarze and McCarthy

Nays: 0

Absent: 0

The motion passed.

Trustee LaRocca moved and Trustee Gieser made the second to place the following items on the Consent Agenda established for this meeting. The results of the roll call vote were as follows:

Ayes: 5 Trustees Hennessey, LaRocca, Gieser, Frusolone and McCarthy

Nays: 0

Absent: 1 Trustee Schwarze

The motion passed.

1. Contract Extension with Beary Landscape Management for Landscape Maintenance Services.

2. Contract Extension with Brancato Landscaping Inc. for Tree Planting Services.
3. Purchase of Trees for Spring Planting with St. Aubin Nursery.
4. Proposal from CH2M for Development of a Phosphorous Optimization Plan and Feasibility Study.
5. Revised Local Public Agency Agreement for Federal Participation-West Branch DuPage River/Fair Oaks Road Trail-Phase III Construction.
6. Purchase of Surface Pro 4 Equipment.
7. Recommendation to approve a First Amendment to Development Agreement with Crafty LLC, an internet retail of craft beer.
8. Ordinance No. 2016-02-07 Amending Chapter 11, Article 2 of the Carol Stream Code of Ordinances by Decreasing the number of Class K Liquor Licenses from 1 to 0 (Crafty LLC d/b/a Crafty) and Increasing the number of Class L Liquor Licenses from 0 to 1 (Crafty LLC d/b/a Crafty) located at 320 E. Fullerton Ave.
9. Ordinance No. 2016-02-08 Amending Chapter 11, Article 2 of the Carol Stream Code of Ordinances by Increasing the number of Class P Liquor Licenses from 6 to 7 (Pilot Travel Centers LLC d/b/a Pilot Travel Center #1041, 170 West North Avenue).
10. Ordinance No. 2016-02-09 Local Amendments to the Adopted Building Construction and Maintenance Codes (Illinois Plumbing Code).
11. Ordinance No. 2016-02-10 Local Amendments to the Adopted Building Construction and Maintenance Codes (Illinois Plumbing Code)
12. Resolution 2852 Declaring Surplus Property owned by the Village of Carol Stream.
13. Raffle License Application-Benjamin Foundation School District 25.
14. Payment of Regular and Addendum Warrant of Bills from February 2, 2016 through February 16, 2016.
15. Treasurer's Report for Month Ended January 31, 2016.

Trustee Hennessey moved and Trustee McCarthy made the second to approve the Consent Agenda for this meeting by Omnibus Vote. The results of the roll call vote were as follows:

Ayes: 5 Trustees Hennessey, LaRocca, Gieser, Frusolone and McCarthy

Nays: 0

Absent: 1 Trustee Schwarze

The motion passed.

The following are brief descriptions of those items approved on the Consent Agenda for this meeting.

Contract Extension with Beary Landscape Management for Landscape Maintenance Services:

The Village Board approved a contract extension with Beary Landscape Management for landscape maintenance services for the period of May 1, 2016 through April 30, 2017 in the amount of \$110,778.

Contract Extension with Brancato Landscaping Inc. for Tree Planting Services:

The Village Board approved a contract extension with Brancato Landscaping Inc. for tree planting services for the period of May 1, 2016 through April 30, 2017 in the amount of \$75.00 per tree planted for a total of \$22,500.

Purchase of Trees for Spring Planting with St. Aubin Nursery:

The Village Board approved the purchase of 100 trees from St. Aubin Nursery for Spring harvesting and planting in the amount of \$17,000.

Proposal from CH2M for Development of a Phosphorous Optimization Plan and Feasibility Study:

The Village Board approved a proposal from CH2M for Development of a Phosphorous Optimization Plan and Feasibility Study at the Water Reclamation Center at a cost not to exceed \$43,522.

Revised Local Public Agency Agreement for Federal Participation-West Branch DuPage River/Fair Oaks Road Trail-Phase III Construction:

The Village Board approved a revised IDOT agreement showing a reduction in the amount of our local share from \$432,268 to \$345,872 for a savings of \$86,396.

Surface Pro 4 Equipment:

The Village Board waived competitive bidding and approved the purchase of 12 Microsoft Surface Pro 4 Computers from Zones at a cost of \$28,983.60.

Recommendation to approve a First Amendment to Development Agreement with Crafty LLC, an internet retail of craft beer:

The Village Board approved amending the Development Agreement with Crafty LLC for their liquor license which will allow for the sale of all alcoholic liquor.

Ordinance No. 2016-02-07 Amending Chapter 11, Article 2 of the Carol Stream Code of Ordinances by Decreasing the number of Class K Liquor Licenses from 1 to 0 (Crafty LLC d/b/a Crafty) and Increasing the number of Class L Liquor Licenses from 0 to 1 (Crafty LLC d/b/a Crafty) located at 320 E. Fullerton Ave.:

The Village Board approved amending Crafty LLC d/b/a Crafty's liquor license to a Class L which includes the sale of all alcoholic liquor.

Ordinance No. 2016-02-08 Amending Chapter 11, Article 2 of the Carol Stream Code of Ordinances by Increasing the number of Class P Liquor Licenses from 6 to 7 (Pilot Travel Centers LLC d/b/a Pilot Travel Center #1041, 170 West North Avenue):

The Village Board approved issuance of a Class P Liquor License for the package sale of beer and wine at their facility located at the southwest corner of Gary and North Avenues.

Ordinance No. 2016-02-09 Local Amendments to the Adopted Building Construction and Maintenance Codes (Illinois Plumbing Code):

The Village Board approved amendments to the Illinois Plumbing Code required by the Illinois Department of Natural Resources in accordance with the new rules for Lake Michigan water allocation permittees, to require the use of water conserving plumbing fixtures bearing the US EPA WaterSense label.

Ordinance No. 2016-02-10 Local Amendments to the Adopted Building Construction and Maintenance Codes (Illinois Plumbing Code):

The Village Board approved local amendments to the Illinois Plumbing Code to reflect administrative procedures, such as the fee schedule, violations and stop work orders, and to include plumbing system specifications unique to Carol Stream and/or the northern Illinois region.

Resolution No. 2852 Declaring Surplus Property owned by the Village of Carol Stream:

The Village Board approved declaring surplus chemicals located within the Public Works Department authorized for proper disposal by a hazardous material company.

Raffle License Application-Benjamin Foundation School District 25:

The Village Board approved a raffle license, fee waiver and manager's fidelity bond waiver for a raffle to be held at Holiday Inn and Suites for a Trivia Night on March 5, 2016.

Regular Bills and Addendum Warrant of Bills:

The Village Board approved payment of the Regular Bills dated February 16, 2016 in the amount of \$637,193.84. The Village Board approved the payment of the Addendum Warrant of Bills from February 2, 2016 thru February 16, 2016 in the amount of \$517,843.07.

Treasurer's Report:

The Village Board received the Revenue/Expenditure Statements and Balance Sheet for the Month Ended January 31, 2016.

Non Consent Agenda

Award of Bid-Farmhouse Exterior Renovation:

Trustee McCarthy moved and Trustee Frusolone made the second to reject all bids and directed staff to bring a contract recommendation to the Village Board at the March 7, 2016 Board meeting. The results of the roll call vote were as follows:

Ayes: 5 Trustees Hennessey, LaRocca, Gieser, Frusolone and McCarthy

Abstain: 0

Absent: 1 Trustee Schwarze

The motion passed.

Report of Officers:

Trustee LaRocca applauded DuPage County, Park District and Village of Carol Stream for working together on the Flood Mitigation Project. Please try Caputo's Fresh Market grocery. Please shop Carol Stream.

Trustee Gieser thanked Robertino Presta Jr. for his presentation on their Carol Stream grocery store. Next month the business spotlight will be Demar Logistics. He thanked the residents from Carolshire for showing up tonight and Jim Zay for all his work on the Flood Mitigation Project. He stated the parade committee met tonight to plan for the July 4th parade. Signed acts include the Jesse White Tumblers, the fire twirling barefoot Hawaiians, the St. Andrews Pipes & Drums and a 7 piece mariachi band.

Trustee Hennessey stated we are 1 month away from the Illinois Primary election. If you have not registered to vote, please do so in this Presidential Election year.

Trustee Frusolone congratulated the female Citizen of the Year Pam Falco who is present in the audience. The male Citizen of the Year is Ed Spoeri, the female special Citizen of the Year is Barb Goepel and the male special Citizen of the Year is Rob Frusolone. Congratulations to the Glenbard North High School speech team who qualified to go to the State meet. Good luck in Peoria. Please shop Carol Stream and thank you Caputo's for being in Carol Stream.

Trustee McCarthy stated he agrees with everything everyone else said. He acknowledged the Judges Award winners which went to Don Depa and Sandy Gbur. He stated he is holding a bags tournament for the Relay for Life Charity at Flip Flops on February 22nd, 24th, 28th, 29th and March 2nd.

**Regular Meeting – Plan Commission/Zoning Board of Appeals
Gregory J. Bielawski Municipal Center, DuPage County, Carol Stream, Illinois**

All Matters on the Agenda may be Discussed, Amended and Acted Upon

February 22, 2016

Chairman Parisi called the Regular Meeting of the Combined Plan Commission/Zoning Board of Appeals to order at 7:00 p.m. and directed Roberta Vogel, Permit Systems Coordinator to call the roll.

The results of the roll call were:

Present: Chairman Frank Parisi, Commissioners David Creighton, Frank Petella, John Meneghini, Angelo Christopher and Charlie Tucek.

Absent: Commissioner Dee Spink.

Also Present: Don Bastian, Community Development Director, Tom Farace Planning and Economic Development Manager, Roberta Vogel, Permit Systems Coordinator, and a representative from DuPage County Court Reporters.

MINUTES:

Commissioner Meneghini moved and Commissioner Creighton made the second to approve the minutes of the meeting of December 14, 2015.

The motion passed by unanimous voice vote.

PUBLIC HEARING:

Commissioner Creighton moved and Commissioner Meneghini made the second to open the Public Hearing.

The motion passed by unanimous voice vote.

Case # 15342, Dunkin' Donuts, 222 W. Army Trail Road

Special Use Permit - Drive-up Service Window

Amendment to an Approved Special Use Permit – Planned Unit Development

Chairman Parisi swore in the witness, Vaishali Katyarmal, Architect, on behalf of Hitesh Patel, Dunkin Donuts.

Vaishali Katyarmal made a short presentation stating the details of the site improvements, scope of intended interior and exterior work and explains reasons for the requested approvals. Dunkin Donuts is presently located on the west end of the Shopping Plaza and would like to move to the east end to allow for a drive thru service to grow his business. To allow the Drive Thru bypass lane there is a need to reduce parking by 5 stalls, 2 stalls located in the rear and 3 stalls located on the east side of the property, explains the new sign locations and location of the safety bollards.

Chairman Parisi asks for any questions from the audience. No audience questions.

Chairman Parisi asks Commissioner for any questions.

Commissioner Meneghini has no questions at this time but requests the opportunity to redirect at a later time.

Commissioner Petella asks about the parking in the rear of the building.

Ms. Katyamal states there are 7 stalls in the rear of the building and they will be eliminating 2 stalls for the by-pass lane leaving 5 stalls for parking.

Commissioner Petella asks about the directional sign location.

Ms. Katyamal states there will be signs at entry off of Army Trail Road as well as the pavement signage.

Commissioner Petella asks about the deliveries at the Plaza.

Ms. Katyamal states the common practice for deliveries at this location is in the front of the building.

Chairman Parisi asks Mr. Farace for the staff report.

Mr. Farace states that Dunkin Donuts is requesting a Special Use for a Drive-up Window Service and an Amendment to the Approved PUD allowing reduced parking stalls. Mr. Farace states Dunkin Donuts is currently a tenant in the Shopping Plaza on the west end and wishes to move to the east end to accommodate the drive thru window lane and by-pass lane, explains the parking reduction and the work to be done on the retaining wall, curb area in the rear of the building to allow for the by-pass lane, states the existing flow of the traffic in the rear of the building currently flows from west to east and will remain the same traffic flow. Mr. Farace states the issues with property maintenance and states the dumpster enclosure gates were left open on several occasions during site visits and staff has noted they should be closed excluding employee usage or trash pick-up. The parking lot has a few pot holes in front of the current business space on the west side of the center and they should be taken care of when the weather improves. There is a parking lot light inoperable on the southeast corner of the plaza as well as on the southeast corner of the building that should be repaired by the property owner. Explains the signage and states the signage will be in compliance with the current sign code. Staff recommends approval of the Special Use and the Amendment to the approved special Use PUD with staff recommendations.

Chairman Parisi asks the Commission Meneghini and Petella for any additional questions.

Commissioner Meneghini asked about the anticipated amount of the business that will become drive-up.

Ms. Katyamal states yes, about 2/3 of the business.

Commissioner Meneghini asks how this was determined.

Ms. Katyamal states Dunkin Donuts has collected data through other Dunkin Donut drive-thru locations and this was used to determine the estimated percentage of drive-thru use from the corporate office.

Commissioner Meneghini asks how long has the owner Mr. Patel had the business, does he have other stores and how many employees.

Mr. Patel states he has been in the business for 5 years; he has other locations and employs 6 staff.

Commissioner Petella has no further questions.

Commissioner Tucek asks about the dumpster location and asks if the garbage truck has enough room to navigate the trash enclosure safely.

Ms. Katyamal states yes.

Commissioner Tucek states he thinks it's a great idea.

Commissioner Creighton has no questions.

Commissioner Christopher asks if the applicant agrees with all the general conditions the village has put together.

Ms. Katyamal states the majority of the conditions of approval pertain to the property owner and they will work with the property owner to correct the conditions. As far as the conditions that apply to Dunkin Donuts we will make sure it is abided by.

Commissioner Christopher asks Mr. Farace who owns the retaining wall.

Mr. Farace states the property owner.

Commissioner Christopher asks about the reduction from 17' to 14'6" should it be protected by a guard rail.

Mr. Bastian states that aspect of the plan will be reviewed during the permit application process by the Engineering Department.

Chairman Parisi asks for clarification from Mr. Farace about the curb area being constructed.

Mr. Farace states it will be in the southeast corner of the property along the by-pass lane.

Chairman Parisi asks about the height limitation and location for the stanchion structure.

Ms. Katyamal states it will be located where the drive-thru begins.

Commissioner Meneghini moved and Commissioner Christopher made the second to approve the request with the staff recommendations are completed.

The results of the roll call vote were:

Ayes: 6 Chairman Parisi and Commissioners Petella, Tucek, Meneghini, Christopher and Creighton.

Nays: 0

Abstain: 0

Absent: 1 Commissioner Spink.

Chairman Parisi reminded the applicant that this request will go before the Village Board on Monday, March 7, 2016, at 7:30 PM for final action.

Case # 15365, 27W245 North Avenue, LLC (AT&T Mobile Tel), 27W245 North Avenue

Zoning Map Amendment – B-3 Service District (Upon Annexation)

Zoning Code Variation – Front Building Setback

Chairman Parisi asks Mr. Bastian for the staff report.

Mr. Bastian explains Case # 15365 for 27W245 North Avenue, LLC (AT&T Mobile Tel) was published for the meeting on February 22, 2016 but has not been completed and asked for Case# 15365 to be continued to the March 28, 2016 meeting.

Chairman Parisi asks for any questions from the commissioners. No Questions.

Commissioner Creighton moved and Commissioner Petella made the second to continue the case to March 28, 2016 meeting.

The results of the roll call vote were:

Ayes: 6 Chairman Parisi and Commissioners Petella, Tucek, Meneghini, Christopher and Creighton.

Nays: 0

Abstain: 0

Absent: 1 Commissioner Spink.

Commissioner Meneghini moved and Commissioner Christopher made the second to close the Public Hearing.

The motion passed by unanimous vote.

PRESENTATION:

Case # 16013 – Village of Carol Stream – 500 N Gary Avenue
2016 Zoning Map

Mr. Farace states the changes to the 2016 Zoning Map.

Chairman Parisi asks if the Planning Commission had any questions. NO questions.

Commissioner Petella moved and Commissioner Meneghini made the second to approve the 2016 Zoning Map.

The results of the roll call vote were:

Ayes: 6 Chairman Parisi and Commissioners Petella, Tucek, Meneghini, Christopher and Creighton.

Nays: 0

Abstain: 0

Absent: 1 Commissioner Spink.

NEW BUSINESS:

Mr. Bastian talks about the Comprehensive Plan Open House in March 2016. Commissioner Creighton asks about any changes and Mr. Bastian states there could be changes as far as refinements. Commissioner Creighton asks Mr. Bastian his opinion of how the Comprehensive Plan is progressing and Mr. Bastian states he is happy with what the end product will be.

ADJOURNMENT:

At 7:35 p.m. Commissioner Meneghini moved and Commissioner Creighton made the second to adjourn the meeting.

The motion passed by unanimous vote.

FOR THE COMBINED BOARD

Recorded and transcribed by,

Roberta Vogel
Permit Systems Coordinator

Minutes approved by Plan Commission on this ____ day of _____, 20 ____.

Chairman

**A RESOLUTION RECOGNIZING ED SAILER
FOR THIRTY YEARS OF SERVICE WITH THE VILLAGE OF CAROL STREAM**

WHEREAS, Ed Sailer began his employment with the Village of Carol Stream as a Patrol Officer in the Police Department on March 13, 1986; and

WHEREAS, Ed Sailer was promoted to Sergeant on May 7, 2001, Lieutenant on April 6, 2009, Deputy Chief of Police on May 3, 2010, and Chief of Police on February 17, 2015; and

WHEREAS, during his career Ed Sailer has served with distinction as Acting Chief of Police, Juvenile Officer, Evidence Technician, Officer in Charge and Field Training Officer; and

WHEREAS, Ed Sailer has received several commendations and awards for his service to the Police Department and community; and

WHEREAS, under his leadership the Carol Stream Police Department remains recognized for its integrity, professionalism, staff development and training, empathy and commitment to community relations; and

WHEREAS, Ed Sailer has served the Village of Carol Stream with distinction for thirty years.

NOW THEREFORE BE IT RESOLVED BY THE MAYOR AND BOARD OF TRUSTEES OF THE VILLAGE OF CAROL STREAM, on behalf of all former and present elected and appointed officials and residents of Carol Stream, as follows:

SECTION 1: Ed Sailer is hereby recognized and commended for his outstanding service and dedication to the Village of Carol Stream.

SECTION 2: Ed Sailer is wished the very best in his future years with the Village of Carol Stream.

This Resolution shall be in full force and effect from and after its passage as approved by law.

PASSED AND APPROVED THIS 7th DAY OF MARCH 2016.

AYES:

NAYS:

ABSENT:

Frank Saverino, Sr., Mayor

ATTEST:

Laura Czarnecki, Village Clerk

**PROCLAMATION
CELEBRATING 2016 EARTH HOUR**

**AGENDA ITEM
C-2 3-7-16**

WHEREAS, in March 2007, the World Wildlife Federation, the world's leading conservation organization organized the 1st Earth Hour campaign in Sydney Australia to solicit the support of citizens, world governments and global businesses to reduce energy use all across our planet; and

WHEREAS, last year's Earth Hour event included the involvement of 172 countries, whose citizens and institutions undertook 620,000 specific actions in support of climate protection that included turning lights off at 10,400 landmarks worldwide; and

WHEREAS, the theme of this year's 10th Anniversary Earth Hour campaign is '**Shine a Light on Climate Action**' that will kick off in the Philippines and work its way across the globe and include the Gift of Light crowd-funding project to purchase and install solar-powered lighting in select Philippine cities; and

WHEREAS, Earth Hour 2016 provides Carol Stream residents, local businesses and governments an opportunity to unite as one community to collectively reduce our locally-generated carbon emissions from indiscriminate energy consumption; and

WHEREAS, residents and business owners are encouraged to visit the Earth Hour 2016 web portal at www.earthhour.org/take-action to see how you, your family, neighborhood or business can take action to combat climate change; and

WHEREAS, this year's effort can be followed on social media using the Twitter hashtag **#changeclimatechange**, on facebook **@earthhour** and on youtube to view the moving 2016 campaign video titled '**The Future Starts Today**'.

NOW, THEREFORE BE IT PROCLAIMED THAT I, Mayor Frank Saverino, Sr. and the Village Board of Trustees, Village of Carol Stream, DuPage County, Illinois in exercise of its Home Rule Powers that the Village hereby celebrates

Earth Hour on Saturday, March 19th

and encourages residents and businesses to turn off all non-essential lighting and appliances between 8:30 - 9:30 PM.

PROCLAIMED THIS 7th DAY OF MARCH 2016.

Frank Saverino Sr. – Mayor

ATTEST:

Laura Czarnecki, Village Clerk

Village of Carol Stream
Interdepartmental Memo

TO: Joseph E. Breinig, Village Manager

FROM: Tom Farace, Planning and Economic Development Manager *TF*

THROUGH: Donald T. Bastian, Community Development Director *DB*

DATE: February 29, 2016

RE: **Agenda Item for the Village Board meeting of March 7, 2016**
PC/ZBA Case 15342, Dunkin' Donuts – 222 W. Army Trail Road
Special Use Permit for Drive-up Service Window and Amendment to an Approved
Special Use Permit for a Planned Unit Development

Hitesh Patel is seeking approval of a Special Use Permit for a Drive-Up Service Window and an Amendment to a Special Use Permit for a PUD to allow for the construction of a drive-through lane for Dunkin' Donuts at 222 W. Army Trail Road in the Commons at Army Trail Plaza. Dunkin' Donuts is currently located in the westernmost tenant space of the plaza, and will relocate to the easternmost tenant space in order to provide a drive-through lane around the south and east sides of the building. A bypass lane is also proposed around the building, which will require the reconfiguration and expansion of the rear drive aisle at the southeast corner of the property. To accommodate the drive-through and bypass lanes, five parallel parking spaces will be eliminated on the south and east sides of the property. Staff believes the remaining 53 on-site parking spaces will accommodate parking demands based on recorded observations at the plaza and parking/drive-through utilization information provided by the applicant.

The staff report presenting the requests, with supporting documentation, was transmitted to the Village Board with the Plan Commission/Zoning Board of Appeals (PC/ZBA) packet on February 19, 2016. At its meeting on February 22, 2016, by a vote of 6-0, the PC/ZBA recommended approval of the Special Use Permit for a Drive-Up Service Window and an Amendment to a Special Use Permit for a PUD. The PC/ZBA recommendations were subject to the conditions in the February 22, 2016, staff report.

Following the PC/ZBA hearing, the operator of the chiropractic office in the plaza contacted staff with concerns about the impact of the drive-through on traffic flow and safety. It is staff's opinion that the design of the drive-through lane and existing configuration of the front parking lot provide adequate space for safe traffic flow and vehicle maneuvering. Staff attempted to address his concerns, but it is unknown if he will attend the Village Board meeting to state his concerns.

If the Village Board concurs with the PC/ZBA recommendation, they should approve the Special Use Permit for a Drive-Up Service Window and an Amendment to an Approved Special Use Permit for a PUD, subject to the conditions contained within the Ordinance, and adopt the necessary Ordinance.

TF:tf

c: Hitesh Patel, Dunkin' Donuts (via email)
Vaishali Katyarmal, Studio Silver Inc. Architecture + Design (via email)

Village of Carol Stream
Interdepartmental Memo

TO: Joseph E. Breinig, Village Manager

FROM: Tom Farace, Planning and Economic Development Manager *TF*

THROUGH: Donald T. Bastian, Community Development Director *DB*

DATE: February 29, 2016

RE: **Agenda Item for the Village Board meeting of March 7, 2016**
PC/ZBA Case 16013, Village of Carol Stream, Official 2016 Zoning Map

As required by state statute, the Village must publish a current zoning map by March 31 of each year. Staff has prepared the draft Village of Carol Stream Official Zoning Map for 2016, which includes the Village Board's approval of one annexation and one special use for planned unit development/rezoning. The map was also modified to clearly delineate properties near the intersection of Schmale and Geneva Roads that are unincorporated versus in the City of Wheaton, and boundaries of surrounding municipalities now have a darker outline for better demarcation. Additional detail regarding the changes authorized by the Village Board during 2015 for the 2016 Zoning Map is provided below.

1. **Special Use for a Planned Unit Development for 170-200 W. North Avenue** – Bluestone Single Tenant Properties, LLC (Pilot Travel Plaza) was approved for a special use for a Planned Unit Development to develop an automobile and commercial vehicle fueling plaza and future retail outlet (PINs will be assigned when the Subdivision Plat is finalized and recorded).
2. **Annexation and Zoning for 27W031 North Avenue** – The Wayne Township governmental office property was annexed to the Village of Carol Stream, and upon annexation, was rezoned to R-1 One-Family Residence District. In addition, the North Avenue Corridor boundary was extended west to include the subject property (PIN 01-36-403-008 and 02-31-301-001).

The staff report and draft zoning map were transmitted to the Village Board with the Plan Commission/Zoning Board of Appeals (PC/ZBA) packet on February 19, 2016. At their February 22, 2016, meeting, the PC/ZBA recommended approval of the Official 2016 Zoning Map by a vote of 6-0.

If the Village Board concurs with the PC/ZBA recommendation, they should approve the Official 2016 Zoning Map and adopt the necessary Resolution.

TF:tf

**VILLAGE OF CAROL STREAM
INTER-DEPARTMENTAL MEMO**

TO: Mayor & Trustees

FROM: Robert Mellor, Assistant Village Manager *Rmm*

DATE: March 2, 2016

RE: Waiver of Bidding & Award of Contract - Farmhouse Exterior Renovation

This project to replace existing siding, soffit, fascia, windows and pediments was previously formally bid with one qualified bidder responding to the published Notice to Bid. The Village Board rejected all bids and directed staff to negotiate a contract for the exterior renovation of the farmhouse at its Board meeting on February 16, 2016.

The renovation project includes the following work:

- Siding & Insulation – Replace existing wood siding with maintenance free vinyl siding to match as closely as possible the existing wood clapboard siding including insulation.
- Soffit & Fascia – Replace existing wood soffit & fascia with maintenance free aluminum.
- Windows – Replace existing single pane, wood windows with energy efficient multi-pane vinyl windows.
- Window Pediments & Trim – Replace existing, exterior wood pediments and trim with polyurethane pediments over windows to match existing wood as closely as possible.

Staff met with DuPree Construction Co., the only previous qualified bidder from the bid opening on February 16, to negotiate a contract for the work specified above and to further refine products to be used to maintain the historic look of the house. References for DuPree Construction Co. stated the work that they performed was very good with no change orders except those requested by the owner. References included home and barn renovation work (windows, siding, trim) for Fermi Labs, the Forest Preserve of Cook County - Camp Sullivan Barn among others. Based on references and before and after pictures of projects done by DuPree their work appears to be of high quality.

Staff recommends waiving the formal bidding process and awarding the contract for exterior renovation of the farmhouse located at 301 W. Lies Road to DuPree Construction Co. in the amount of \$58,637.80. There are sufficient funds in the Municipal Buildings budget to pay for this expense.

I am available should you have any questions.

DuPree Construction Co.
132 McDonald Avenue, Joliet, IL 60431
815-436-8232 Fax 815-695-5248

www.dupreeconst.com

Proposal Submitted to:

Village of Carol Stream
500 N Gary Avenue
Carol Stream, IL 60188-1899

Date: February 23, 2016

Phone 630-665-7050
Fax 630-665-1064
rescher@carolstream.org
bmellor@carolstream.org

We are pleased to submit the following proposal to furnish materials and /or labor for the completion of:

JOB ADDRESS: Historic Farmhouse, 301 W Lies Rd, Carol Stream, IL

- Install aluminum soffit and aluminum fascia cover to all eaves and overhangs. To be vented properly. All aluminum fascia will be manufactured to detail the existing crown moulding as close as possible. Install vinyl bead board soffit to front porch ceiling.
- Remove and dispose of existing window sashes, header pediments and side trim.
- Install new Alliance Belmont series vinyl replacement windows to same openings. Apply spray foam insulation to exterior perimeter. Manufacture and install aluminum wrapping to exterior casing/frame. Install new Fypon #WCHSEG28x11BT header pediments to 18 locations and #MLD612-12 side trim to windows that previously had them. Apply a color-coordinated sealant as needed for a weather-tight seal.
- Install a fan-folded foam backer over existing wood siding.
- Install Tyvek moisture resistant wind barrier over all walls to be sided. Apply 2" Tyvek tape to all seams, windows, doors, and penetrations.
- Install a .044 thick vinyl siding to entire house. Includes all necessary color-coordinated aluminum flashing, standard vinyl accessories, 4" vinyl outside corner posts, and a standard color.
- Manufacture and install aluminum wrapping to 3 entry doors, front bumpout window posts, and all frieze trim.
- Provide painting on all fypon products.

NOTES:

- 31 Double-hung windows/7 basement hopper windows will have the following features:
White interior, White exterior, Low-E Argon gas-filled glass, ½ screen, Lifetime glass and frame warranty
- We will replace any deteriorated wood as needed.
- Carol Stream will provide documentation that house is free from lead hazards
- We will install aluminum wrapping to the lower section of the front bumpout window to best replicate its current appearance.
- Upgraded exterior window color to 31 locations included

\$58,637.80

Respectfully Submitted Dave DuPree/lc

ACCEPTANCE OF PROPOSAL

The above prices, specifications and conditions are satisfactory and are hereby accepted. You are authorized to do the work as specified. To accept proposal, sign and return solid white copy.

Date _____

Signature _____

Any alteration or deviation from above specifications involving extra cost, will be executed only upon written orders, and will become an extra charge over and above the estimate. Agreements are contingent upon strikes, accidents or delays beyond our control. Owner is to carry fire, tornado and other necessary insurance upon above work. Workman's Compensation and Public Liability insurance on above work will be taken out by DuPree Construction Co. and provided by Hastings Mutual Ins.

1-year labor warranty

Payment upon completion



Certified Professionals



Contractors Association of Will and Grundy Counties

VILLAGE OF CAROL STREAM

CONTRACT FOR FARMHOUSE RENOVATION

THIS CONTRACT, made this ____ day of _____, 2016, by and between the VILLAGE OF CAROL STREAM an Illinois Municipal Corporation, hereinafter called the "Village" and DUPREE CONSTRUCTION COMPANY, an Illinois Corporation, hereinafter called the "Contractor."

For and in consideration of their mutual promises, covenants and undertakings, set forth in this Contract and the Contract Documents, the parties hereto do hereby agree as follows:

ARTICLE I - WORK TO BE DONE BY THE CONTRACTOR

Contractor agrees, at its own cost and expense, to do all work and to furnish all the labor, materials, equipment and other property to do, construct, install, and complete all the works and improvements included, all in full accordance with and in compliance with and as required by the hereinafter specified Contract Documents for said work and improvements, and to do, at its own cost and expense, all other things required of the Contractor by said Contract Documents. All work shall be completed in a professional and workmanlike manner. The Contractor represents and warrants that it has the requisite experience, ability, inventory, capital, facilities, equipment, plant, organization, and staff to enable the Contractor to complete the work at the Contract Price and within the contract time set forth herein.

ARTICLE II - CONTRACT DOCUMENTS

The Contract Documents consist of the following:

1. The General Specifications
2. The General Conditions of the Contract
3. The Contract
4. The Public Contract Statements
5. All Bonds, Insurance Certificates and Insurance Policies mentioned or referred to in the

foregoing documents.

6. Any and all other documents or papers included or referred to in the foregoing documents all of which documents are on file in the OFFICE OF THE VILLAGE MANAGER, 500 N. Gary Avenue, Carol Stream, Illinois, all said documents being hereby incorporated herein and made a part herein by reference the same as if set forth herein.

ARTICLE III - CONTRACT AMOUNT

The Contractor agrees to receive and accept the amount of Fifty-eight thousand six hundred thirty-seven dollars and eighty cents (\$58,637.80) as full compensation for furnishing all materials and equipment and for doing all the work contemplated and embraced in the Contract; also for all loss or damage arising out of the nature of the work aforesaid, or from the action of the elements, or from any unforeseen difficulties or obstructions which may arise or be encountered in the execution of the work until its acceptance by the Village, and for all risks of every description connected with the work; also for well and faithfully completing the work, and the whole thereof, in the manner and according to and in compliance with the Contract Documents and the requirements of the Village.

ARTICLE IV – CONFLICT BETWEEN COMPONENT PARTS OF CONTRACT

In the event that any provision in any of the following component parts of this Contract conflicts with any provision in any other of the following component parts, the provision in the component part which follows it numerically except as may be otherwise specifically stated applies. Said component parts are the following:

1. General Conditions of Contract
2. General Specifications

This Contract is intended to conform in all respects to applicable statutes of the State in which the work is to be constructed, and if any part or provision of this Contract conflicts therewith, the said statute shall govern.

ARTICLE V – CONTRACT TIME

The Contractor shall fully complete all work to the point of final acceptance by the Village, and to complete doing all other things required of them by the Contract Documents on or before and no later than Friday, April 29, 2015. Contractor shall and agrees to furnish and deliver to the Village fifteen (15) calendar days after date of award of this contract the Performance and Payment Bond and the Insurance Certificates and Policies of Insurance required of him by the provisions of Paragraph 2 of the General Conditions of the Contract, and to do, prior to starting work, all other things which are required of them by the Contract Documents as a prerequisite of starting work.

ARTICLE VI – LIQUIDATED DAMAGES

If the Contractor shall fail to complete the work within the Contract Time which shall include any proper extension granted by the Village, the Contractor shall pay to the Village an amount equal to Five Hundred Dollars (\$500) per calendar day for each day past the Contract Time until final acceptance by the Village.

ARTICLE VII – PREVAILING WAGE ACT

This Contract requires the payment of prevailing wages. Contractor shall not pay less than the prevailing rates of wages to all laborers, workmen, and mechanics performing work pursuant to this Contract and shall fully comply with all of the requirements of the Illinois Prevailing Wage Act (820 ILCS 130/1-12).

ARTICLE VIII

The Village agrees with said Contractor to employ, and does hereby employ, the said Contractor to provide the materials and do all the work, and do all other things hereinabove mentioned, according to the terms and conditions hereinabove contained or referred to, for the price aforementioned, and hereby contracts to pay the same at the time, in the manner and upon the conditions set forth or referred to in the Contract Documents; and the said parties for themselves, their heirs, executors,

administrators, successors and assigns, do hereby agree to the full performance of the covenants herein contained.

ARTICLE IX – MISCELLANEOUS PROVISIONS

A. Contractor shall comply with all applicable laws, regulations and rules promulgated by any federal, state, local, or other governmental authority or regulatory body pertaining to all aspects of the Work, now in effect, or which may become in effect during the performance of the Work. The scope of the laws, regulations, and rules referred to in this paragraph includes, but is in no way limited to, the Illinois Human Rights Act, Illinois Equal Pay Act of 2003, Occupational Safety & Health Act along with the standards and regulations promulgated pursuant thereto (including but not limited to those safety requirements involving work on elevated platforms), all forms of traffic regulations, public utility, Interstate and Intrastate Commerce Commission regulations, Workers' Compensation Laws, Public Construction Bond Act, Prevailing Wage Laws, Public Works Preference Act, Employment of Illinois Workers on Public Works Act, USA Security Act, federal Social Security Act (and any of its titles), and any other law, rule or regulation of the Illinois Department of Labor, Department of Transportation, Illinois Environmental Protection Act, Illinois Department of Natural Resources, Illinois Department of Human Rights, Human Rights Commission, EEOC, and the Village of Carol Stream.

B. Contractor shall comply with the provisions of the Illinois Public Works Employment Discrimination Act and the Illinois Human Rights Act/Equal Opportunity Clause which, pursuant to Illinois law, are deemed to be part of this Contract. The relevant provisions will be fully incorporated into the Contract by reference and set forth in full.

C. No amendment or modification to the Contract shall be effective until it is reduced to writing and approved and executed by the corporate authorities of the parties in accordance with all applicable statutory procedures.

D. Neither this Contract, nor any interest herein, shall be assigned or subcontracted, in

whole or in part, by the Vendor except upon the prior written consent of the Village.

E. This Contract shall be governed by, construed and enforce in accordance with the internal laws, but not the conflicts of laws rules, of the State of Illinois. Venue shall be in the Circuit Court of DuPage County, Illinois.

F. It is hereby expressed to be the intent of the parties to this Contract that should any provision, covenant, agreement, or portion of this Contract, the Contract Documents or their application to any Person or property be held invalid by a court of competent jurisdiction, the remaining provisions of this Contract, the Contract Documents and the validity, enforceability, and application to any Person or property shall not be impaired thereby, but the remaining provisions shall be interpreted, applied, and enforced so as to achieve, as near as may be, the purpose and intent of this Contract to the greatest extent permitted by applicable law.

IN WITNESS WHEREOF, the parties hereto have caused this Contract to be executed by their duly authorized representatives as of the date first above written.

CONTRACTOR:

BY: _____

TITLE: _____

ATTEST:

BY: _____

TITLE: _____

THE VILLAGE OF CAROL STREAM

BY: _____
VILLAGE MANAGER

**VILLAGE OF CAROL STREAM
SIDING, SOFFIT, FASCIA, WINDOWS & PEDIMENT REPLACEMENT
GENERAL SPECIFICATIONS**

1. DESCRIPTION OF WORK

The contractor shall furnish all materials and perform all of the work on the property located at 301 W. Lies Rd. Carol Stream Illinois for the contract and terms noted below. The Contractor will install new P-14 fan fold insulation, Tyvek house wrap, vinyl siding, soffit and crown molding, bead board ceiling on front porch along with replacement windows with window pediments and replacement of all rotted wood and clapboard where needed.

2. SPECIFICATIONS OF WORK

A. WOOD REPLACEMENT:

Removal of all deteriorated and bad wood and replaced with new wood as needed.

B. HOUSE WRAP:

Install Tyvek© or Typar© or equivalent. Wrap to be installed over clapboard. Apply 2" Tyvek tape to all seams, windows, doors and penetrations.

C. INSULATION:

Install P-14 fan fold foam insulation to be placed over wrap.

D. SIDING:

Install siding to be of .044-gauge off white vinyl. Includes all necessary color coordinated aluminum flashing, standard vinyl accessories, 4" vinyl outside corner posts, and a standard color.

E. VINYL SOFFIT:

Install aluminum soffit, same gauge as siding to cover all eaves and overhangs, to be vented every 5 feet (5').

F. FASCIA:

Install fascia to be made of aluminum and to be manufactured to detail of the existing crown molding as close as possible.

G. BEAD BOARD CEILING:

Install vinyl bead board to front porch ceiling, same gauge of vinyl as siding.

H. HOUSE WINDOWS:

Remove and dispose of all existing window sashes, header pediments and side trim. Install Alliance Belmore series vinyl replacement windows, low E Argon gas filled double pane glass, U-Factor of 0.29 Solar Heat Gain Coefficient to meet or exceed Energy Star rating, white exterior/white interior, with half screen. Apply spray foam insulation to exterior perimeter. Manufacture and install aluminum wrapping to exterior casing/frame. Install new Fypon #WCHSEG28x11BT header pediments to 18 locations

and #MDL612-12 side trim to windows what previously had them. Apply a color coordinated sealant as needed for weather tight seal. All windows shall have a lifetime frame and glass warranty. All Fypon products to be painted. 31 windows shall be double-hung with upgraded exterior window color and 7 basement hopper windows.

I. WRAPPING:

Manufacture and install aluminum wrapping to 3 entry doors, front bumpout window and frieze trim. Aluminum wrapping to be installed to the lower section of the front bumpout window shall best replicate its current appearance.

3. SPECIFICATIONS GENERAL

3.0 Owner occupancy

- A. The owner will occupy the site periodically for the purposes of conducting meetings. No work shall be scheduled for Saturday April 16 or Sunday April 17, 2016.
- B. The Contractor shall cooperate with owner to minimize conflict and to facilitate owner's operations.
- C. The Contractor shall schedule the work to accommodate any owner occupancy.

3.1 Care and protection of property

- A. Contractor shall be responsible for the preservation of all public and private property and use every precaution necessary to prevent damage thereto. If any direct or indirect damage is done to public or private property by or on account of any act, omission, neglect, or misconduct in the execution of the work on the part of the contractor, restore such property to a condition similar or equal to that existing before the damage was done, or make good the damage in other manner acceptable to the owner.

3.2 Work coordination and sequence

- A. Construct work in stages to accommodate owner's occupancy requirements during construction period, coordinate construction schedule and operations with owner.

3.3 Protection and relocation of existing structures and utilities

- A. The contractor shall assume full responsibility for the protection of all building, structures, and utilities, public and private, including poles, signs, services to buildings, sewers, drains, and electric and telephone cables, in the work area whether or not they are on the drawings. The contractor shall carefully support and protect all such structures and utilities from damage of any kind. Any damage resulting from the contractor's operations shall be repaired at contractor's own expense.
- B. Protection and temporary removal and replacement of existing utilities and

structures shall be part of the work under this contract and all costs in connection therewith shall be included in the Contract price.

3.4 CHANGE PROCEDURES

- A. Submit name of individual authorized to receive change documents, and be responsible for informing others in Contractor's employ or Subcontractors of changes to the Work.
- B. Contractor may propose changes by submitting a request for change to the Village of Carol Stream Assistant Village Manager or his designee, describing proposed change and its full effect on the Work. Include a statement describing reason for the change, and effect on Contract Sum/Price and Contract Time with full documentation.
- C. Document each quotation for change in cost or time with sufficient data to allow evaluation of quotation. On request, provide additional data to support computations
- D. Execution of Change Orders: Change order shall not be considered valid until executed by both the Village and the Contractor.

3.5 DEFECT ASSESSMENT

- A. Replace the Work, or portions of the Work, not conforming to specified requirements.
- B. The defective Work may remain, but unit sum/price will be adjusted to a new sum/price at discretion of Owner.

3.6 SHOP DRAWINGS

- A. Shop Drawings: Submit to Village for review for limited purpose of checking for conformance with information given and design concept expressed in Contract Documents.
- B. Indicate special utility and electrical characteristics, utility connection requirements, and location of utility outlets for service for functional equipment and appliances.
- C. Submit number of opaque reproductions Contractor requires, plus two copies which will be retained by the Village.

3.7 PROPOSED PRODUCTS LIST

- A. Within ten (10) calendar days after date of Village-Contractor Agreement, submit complete list of major products proposed for use, with name of manufacturer, trade name, model number of each product and samples & color of Siding, Soffit, Fascia, Window & Pediment Replacement products.

- B. For products specified only by reference standards, give manufacturer, trade name, model or catalog designation, and reference standards.

3.8 PROJECT RECORD DOCUMENTS

- A. Maintain on site one set of the following record documents; record actual revisions to the Work:
 - 1. Drawings.
 - 2. Specifications.
 - 3. Addenda.
 - 4. Change Orders and other modifications to the Contract.
 - 5. Reviewed Shop Drawings, Product Data, and Samples.
 - 6. Manufacturer's instruction for assembly, installation, and adjusting.
- B. Record information concurrent with construction progress, not less than weekly.
- C. Specifications: Legibly mark and record at each product section description of actual products installed, including the following:
 - 1. Manufacturer's name and product model and number.
 - 2. Product substitutions or alternates utilized.
 - 3. Changes made by Addenda and modifications.
- D. Record Drawings and Shop Drawings: Legibly mark each item to record actual construction including:
 - 1. Field changes of dimension and detail.
 - 2. Details not on original Contract drawings.
- E. Submit lien waivers and documents to Village with claim for progress and final Application for Payments.

3.9 PRODUCT WARRANTIES AND PRODUCT BONDS

- A. Obtain, execute and assemble transferable warranty documents and bonds in duplicate by responsible subcontractors, suppliers, and manufacturers, within ten (10) calendar days after completion of work.

B. Submit warranty documents prior to final Application for Payment.

3.10 Permits

A. Contractor shall be responsible for securing all permits for this job prior to start of work however the Village will issue the permits without a fee requirement.

B. Contractor shall be responsible for scheduling all inspections with the Village Building Division - Permit Systems Coordinator who can be reached at 630-871-6238 (rvogel@carolstream.org).

3.11 Village Liaison

A. The onsite Village liaison for this project is Rick Lescher, Municipal Buildings and Grounds Maintenance Supervisor who can be reached at 630-774-0554 (rlescher@carolstream.org).

GENERAL CONDITIONS OF THE CONTRACT

1. Contract Security

The Contractor shall furnish a Performance and Payment bond in an amount at least equal to 100 percent of the aggregate amount of the Contract as security for the faithful performance of the Contract and for the payment of all persons performing labor and furnishing materials in connection with this Contract.

2. Contractor's Insurance

Contractor shall procure and maintain, for the duration of the Contract, insurance against claims for injuries to persons or damages to property, which may arise from or in connection with the performance of the work hereunder by the Contractor, his agents, representatives, employees or subcontractors.

A. Minimum Scope of Insurance: Coverage shall be at least as broad as:

1. Insurance Services Office Commercial General Liability occurrence form CG 0001 with the Village named as additional insured, on a form at least as broad as the ISO Additional Insured Endorsement CG 2010 and CG 2026
2. Insurance Service Office Business Auto Liability coverage form number CA 0001, Symbol 01 "Any Auto."
3. Workers' Compensation as required by the Labor Code of the State of Illinois and Employers' Liability insurance.
4. Builder Risk Property Coverage with Village as loss payee
5. Environmental Impairment/Pollution Liability Coverage for pollution incidents as a result of a claim for bodily injury, property damage or remediation costs from an incident at, on or migrating beyond the contracted work site. Coverage shall be extended to Non-Owned Disposal sites resulting from a pollution incident at, on or mitigating beyond the site; and also provide coverage for incidents occurring during transportation of pollutants.

B. Minimum Limits of Insurance: Contractor shall maintain limits no less than:

1. Commercial General Liability: \$1,000,000 combined single limit per occurrence for bodily injury, personal injury and property damage. The general aggregate shall be twice the required occurrence limit. Minimum General Aggregate shall be no less than \$2,000,000 or a project/contract specific aggregate of \$1,000,000.
2. Business Automobile Liability: \$1,000,000 combined single limit per accident for bodily injury and property damage.
3. Workers' Compensation and Employers' Liability: Workers' Compensation coverage with statutory limits and Employers' Liability limits of \$500,000 per accident.
4. Environmental Impairment/Pollution Liability: \$1,000,000 combined single limit per occurrence for bodily injury, property damage and remediation costs

C. Deductibles and Self-Insured Retentions

Any deductibles or self-insured retentions must be declared to and approved by the Village. At the option of the Village, either: the insurer shall reduce or eliminate such deductibles or self-insured retentions as it respects the Village, its officials, agents, employees and volunteers; or the Contractor shall procure a bond guaranteeing payment of losses and related investigation, claim administration and defense expenses.

D. Other Insurance Provisions

The policies are to contain, or be endorsed to contain, the following provisions:

1. General Liability and Automobile Liability Coverages:
The Village, its officials, agents, employees and volunteers are to be covered as insureds as respects: liability arising out of activities performed by or on behalf of the Contractor; products and completed operations of the Contractor; premises owned, leased or used by the Contractor; or automobiles owned, leased, hired or borrowed by the Contractor. The coverage shall contain no special limitations on the scope of protection afforded to the Village, its officials, agents, employees and volunteers.
2. The Contractor's insurance coverage shall be primary as respects the Village, its officials, agents, employees and volunteers. Any insurance or self-insurance maintained by the Village, its officials, agents, employees and volunteers shall be excess of Contractor's insurance and shall not contribute with it.
3. Any failure to comply with reporting provisions of the policies shall not affect coverage provided to the Village, its officials, agents, employees and volunteers.
4. The Contractor's insurance shall contain a Severability of Interests/Cross Liability clause or language stating that Contractor's insurance shall apply separately to each insured against whom claim is made or suit is brought, except with respect to the limits of the insurer's liability.
5. If any commercial general liability insurance is being provided under an excess or umbrella liability policy that does not "follow form," then the Contractor shall be required to name the Village, its officials, employees, agents and volunteers as additional insureds
6. All general liability coverages shall be provided on an occurrence policy form. Claims-made general liability policies will not be accepted.
7. The contractor and all subcontractors hereby agree to waive any limitation as to the amount of contribution recoverable against them by the Village. This specifically includes any limitation imposed by any state statute, regulation, or case law including any Workers' Compensation Act provision that applies a limitation to the amount recoverable in contribution such as *Kotecki v. Cyclops Welding*

E. All Coverages:

Each insurance policy required by this paragraph shall be endorsed to state that coverage shall not be suspended, voided, cancelled, reduced in coverage or in limits except after thirty (30) days prior written notice by certified mail, return receipt requested, has been given to the Village.

F. Acceptability of Insurers

Insurance is to be placed with insurers with a Best's rating of no less than A-, VII and licensed to do business in the State of Illinois.

G. Verification of Coverage

Contractor shall furnish the Village with certificates of insurance naming the Village, its officials, agents, employees, and volunteers as additional insured's and with original endorsements, affecting coverage required herein. The certificates and endorsements for each insurance policy are to be signed by a person authorized by that insurer to bind coverage on its behalf. The certificates and endorsements are to be received and approved by the Village before any work commences. The Village reserves the right to request full certified copies of the insurance policies and endorsements.

H. Subcontractors

Contractor shall include all subcontractors as insured's under its policies or shall furnish separate certificates and endorsements for each subcontractor. All coverage's for subcontractors shall be subject to all of the requirements stated herein.

3. Assumption of Liability

The contractor assumes liability for all injury to or death of any person or persons including employees of the contractor, any subcontractor, any supplier or any other person and assumes liability for all damage to property sustained by any person or persons occasioned by or in any way arising out of any work performed pursuant to the Contract.

4. Indemnity/Hold Harmless Provision

A. To the fullest extent permitted by law, the Contractor hereby agrees to defend, indemnify and hold harmless the Village, its officials, agents and employees against all injuries, deaths, loss, damages, claims, patent claims, suits, liabilities, judgments, cost and expenses, which may in anywise accrue against the Village, its officials, agents and employees arising in whole or in part or in consequence of the performance of this work by the Contractor, its employees, or subcontractors, or which may in anywise result therefore, except that arising out of the sole legal cause of the Village, its agents or employees, the Contractor shall, at its own expense, appear, defend and pay all charges of attorneys and all costs and other expenses arising therefore or incurred in connections therewith, and, if any judgment shall be rendered against the Village, its officials, agents and employees in any such action, the Contractor shall, at its own expense, satisfy and discharge the same. Contractor expressly understands and agrees that any performance bond or insurance policies required by this contract, or otherwise provided by the Contractor, shall in no way limit the responsibility to indemnify, keep and save harmless and defend the Village, its officials, agents and employees as herein provided.

B. Kotecki Waiver. In addition to the requirements set forth above, the Contractor (and any subcontractor into whose subcontract this clause is incorporated) agrees to assume the

entire liability for all personal injury claims suffered by its own employees and waives any limitation of liability defense based upon the Worker's Compensation Act and cases decided there under. Contractor agrees to indemnify and defend the Village from and against all such loss, expense, damage or injury, including reasonable attorneys' fees, which the Village may sustain as a result of personal injury claims by Contractor's employees, except to the extent those claims arise as a result of the Village's own negligence.

5. Retention of Payments:

The Contractor further agrees that to the extent that money is due the Contractor by virtue of this contract as shall be considered necessary in the judgment of the Village, may be retained by the Village to protect itself against said loss until such claims, suits, or judgments shall have been settled or discharged and/or evidence to that effect shall have been furnished to the satisfaction of the Village.

6. Patent Fees and Royalties:

Contractor shall indemnify and hold harmless the Village and anyone directly or indirectly employed by either of them from and against all claims, damages, losses, and expenses (including attorneys' fees and court and arbitration costs) arising out of any infringement of patent rights or copyrights incident to the use in the performance of the work or resulting from the incorporation in the work of any invention, design, process, product, or device not specified in the Contract Documents, and shall defend all such claims in connection with any alleged infringement of such rights.

7. Request for Payment:

Contractor shall submit sworn Contractor's affidavit along with executed lien waivers with request for payment. Request for payment shall be made on AIA Document forms G702 and G703 or on an equivalent Village approved form. Payment shall be made pursuant to the Illinois Local Government Prompt Payment Act (50 ILCS 505/1 et seq.)

8. Certificate of Authority and Surety Certificate

The Contractor shall furnish the Village with a current Certificate of Authority or Surety Certificate issued by the Illinois Department of Insurance (IDOI) for the bonding company that they are using.

The Contractor shall also furnish the Village with a current Certificate of Authority issued by the Illinois Department of Insurance (IDOI) for the insurance company that they are using.

9. Contract Documents

The Contract Documents and any work shown therein shall be executed the same as if specifically mentioned herein and should any discrepancy between Contract Documents appear, the ruling of the Assistant Village Manager on the interpretation thereof shall be final and binding.

It is the intention of the Contract Documents to provide for this improvement in a complete, thorough and workman-like manner. The Contractor to whom the work is awarded shall furnish all materials, labor, tools, appliances, appurtenances, and all things necessary to complete the work in

accordance with these Contract Documents, and anything omitted that may be interpreted as reasonably necessary to such completion is to be merged into the Contract price.

10. Changes

If the Village deems it proper or necessary in the execution of the work to make any alteration which will increase or diminish the quantity of labor or material or the expense of the work, even to the elimination of one or more items, such alteration shall not annul or vitiate the Contract hereby entered into; provided, however, that the value of any work added or diminished shall be determined by mutual Contract between the Village and Contractor, before such work shall be commenced.

11. Extra Work

No claim whatsoever will be allowed the Contractor for changes, extra work or material not completed or necessary for the completion of the work described, or for a greater amount of money than is hereby stipulated to be paid, unless the change in or addition to the work requiring additional outlay by the Contractor is first ordered in writing by the Village, and the price therefore agreed to in writing.

Minor changes or small modifications in the specifications which may be made to suit some special condition or situation shall not be construed as a precedent for like changes at other times, nor shall such modifications be construed by the Contractor as removing the work from the specifications of the work, and placing it under the category of "Extra Work".

12. Notice of Starting Work

The Contractor shall notify the Village forty-eight (48) hours before beginning any work on this Contract, or of its intention so to do; in case of a temporary suspension of the work he shall give a similar notice before resuming same.

13. Sequence

The Village shall have the power to direct the order and sequence of the work. On any major portion of the work, all accessories shall be set coincident with the main construction. Payment for major portion of the work may be withheld until proper completion of accessories.

14. Supervision

The Village shall have override power to superintend and direct the work, and the Contractor shall perform all of the work herein specified, to its entire satisfaction, approval and acceptance.

15. Contractor's Representative

The Contractor shall have at all times a competent foreman or superintendent at the work site, who shall have full authority to act for the Contractor and to receive and execute orders from the Village and any instructions given to such superintendent or person, executing work for the Contractor, shall be binding on the Contractor as though it was personally given to the Contractor.

16. Workers

The Contractor shall employ competent staff and shall discharge, at the request of the Village, any incompetent, unfaithful, abusive or disorderly workers in its employ. None but staff expert in their respective branches of work shall be employed where special skill is required.

The Contractor shall provide and maintain such sanitary accommodations for the use of its employees as may be necessary to comply with the State and local Board of Health requirements. Public nuisances will not be permitted.

17. Termination of Contract

If, at any time, the Village shall be of the opinion that the work under this Contract is unnecessarily delayed and will not be finished in the prescribed time, or that the work is not being performed in a satisfactory manner, he will so notify the Contractor in writing. If the Contractor has not within ten (10) calendar days thereafter taken such measures, as will in the judgment of the Village, insure the satisfactory completion of the work under this Contract, the Village may notify the Contractor to discontinue all work under the Contract and proceed to terminate the Contract.

18. Construction Schedule

The Contractor is to commence work at the site after receiving a written notice to proceed and within fifteen (15) calendar days after the effective date of the award of the Contract. The Contractor is to fully complete all work covered by this contract to the point of final acceptance by the Village on or before Friday, April 29, 2015.

19. Freedom of Information Act

Within five (5) business days after the Village's Notice to the Contractor of the Village's receipt of a request made pursuant to the Illinois Freedom of Information Act [ILCS 140/1 et seq. – herein "FOIA"], the Contractor shall furnish all requested records in the Contractor's possession which are in any manner related to this Contract, including but not limited to any documentation related to the Village and associated therewith. The Contractor shall not apply any costs or charge any fees to the Village or any other person, firm or corporation for its procurement and retrieval of such records in the Contractor's possession which are sought to be copied or reviewed in accordance with such FOIA request or requests. The Contractor shall defend, indemnify and hold harmless the Village including its several departments and including its officers and employees and shall pay all of the Costs associated with such FOIA request for requests including Costs arising from the Contractor's failure or alleged failure to timely furnish such documentation and/or arising from the Contractor's failure or alleged failure otherwise to comply with the FOIA, whether or not associated with the Contractor's and/or the Village's defense of any litigation associated therewith. In addition, if the Contractor requests the Village to deny the FOIA request or any portion thereof by utilizing one or more of the lawful exemptions provided for in the FOIA, the Contractor shall pay all Costs in connection therewith. As used herein, "in the Contractor's possession" includes documents in the possession of any of the Contractor's officers, agents, employees and/or independent contractors; and "Costs" includes but is not limited to attorney fees, witness fees, filing fees and any and all other expenses — whether incurred by the Village or the Contractor.

20. Contractor Certifications

- A. Contractor certifies it is not barred from bidding on or entering into public contracts due to having been convicted of bid-rigging or bid rotating under paragraph 5/33E-3 or 5/33E-4 of the Illinois Criminal Code. The undersigned also certifies that no officers or employees of the bidder or contractor have been so convicted and that the bidder or contractor is not the successor company or new company created by the officers or owners of one so convicted. It is further certified that any such conviction occurring after the date of this certification will be reported to the above named public body, in writing, within seven (7) days of such conviction, if it occurs during any bidding process, contract term or otherwise prior to entering into any contract herewith.
- B. Contractor certifies that it has a written Sexual Harassment Policy in full compliance with 775 ILCS 5/2-105(A)(4).
- C. Contractor certifies that it shall comply with the provisions of the Equal Employment Opportunity Clause, the Illinois Human Rights Act or Applicable Rules and Regulations of the Illinois Department of Human Rights. Contractor acknowledges that in the event of the Contractor's non-compliance with the provisions of the Equal Employment Opportunity Clause, the Illinois Human Rights Act or Applicable Rules and Regulations of the Illinois Department of Human Rights, the contractor may be declared ineligible for future contracts or subcontracts with the State of Illinois or any of its political subdivisions or municipal corporations, and the contract may be cancelled or voided in whole or part, and such other sanctions or penalties may be imposed or remedies invoked as provided by statute or regulations.
- D. Contractor agrees to fully comply with the provisions of 820 ILCS 265/1. et seq., which include prior to commencement of work on a municipal project, having in place a written substance abuse program for the prevention of substance abuse among its employees which meets or exceeds the program requirements identified in this Act. The substance abuse policy shall be submitted in writing to the municipality and shall be made available to the general public.
- E. Contractor agrees to comply with the requirements of the Toxic Substance Disclosure to Employees Act, for any materials, supplies, and covered by said Act.
- F. All products supplied shall meet all applicable federal, state and local standards for product safety. Products and containers shall be properly labeled to meet all applicable standards and regulations regarding safety, toxicity and other standards. Material Safety Data Sheets (MSDS) shall be supplied as required for all affected products at all sites and the Contractor is responsible to keep all MSDS sheets current.

VILLAGE OF CAROL STREAM PUBLIC CONTRACT STATEMENTS

The Village of Carol Stream is required to obtain certain information in the administration and awarding of public contracts. The following Public Contract Statements shall be executed and notarized.

PUBLIC CONTRACT STATEMENTS

CERTIFICATION OF CONTRACTOR

In order to comply with 720 Illinois Compiled Statutes 5/33 E-1 et seq., the Village of Carol Stream requires the following certification be acknowledged:

The below-signed contractor hereby certifies that it is not barred from bidding or supplying any goods, services or construction let by the Village of Carol Stream with or without bid, due to any violation of either Section 5/33 E-3 or 5/33 E-4 of Article 33E, Public Contracts, of the Chapter 720 of the Illinois Compiled Statutes, as amended. This act relates to interference with public contracting, bid rigging and rotating, kickbacks, and bidding.

CERTIFICATION RELATIVE TO 65 ILCS 5/11-42.1.1

In order to comply with 65 Illinois Compiled Statutes 5/11-42.1.1, the Village of Carol Stream requires the following certification:

The undersigned does hereby swear and affirm that it is not delinquent in the payment of any tax administered by the Illinois Department of Revenue unless it is contesting in accordance with the procedures established by the appropriate revenue Act, its liability for the tax or the amount of the tax. The undersigned further understands that making a false statement herein: (1) is a Class "A" misdemeanor, and (2) voids the contract and allows the Village to recover all amounts paid to it under the contract.

CONFLICT OF INTEREST

The undersigned certifies the following verification relative to conflict of interest and compliance with general ethics requirements of the Village:

The undersigned supplier hereby represents and warrants to the Village of Carol Stream as a term and condition of acceptance of this Contract that none of the following Village Officials is either an officer or director of supplier or owns five percent (5%) or more of the Supplier: the Village Mayor, the members of the Village Board of Trustees, the Village Clerk, the Village Treasurer, the members of the Zoning Board of Appeals and the Plan Commission, the Village Manager and his Assistant or Assistants, or the heads of the various departments within the Village.

If the foregoing representation and warranty is inaccurate, state the name of the Village official who either is an officer or director of your business entity or owns five percent (5%) or more thereof:

(Official) _____

Print Name of Contractor

Signature

Title

Subscribed and sworn to before me this
_____ day of _____, 2016.

Notary Public

Notary expires : _____

PERFORMANCE AND PAYMENT BOND

Bond Number: _____

KNOW ALL MEN BY THESE PRESENTS, That _____

as Principal, and _____

as Surety, are held and firmly bound unto _____ the full

and just sum of _____ Dollars

(\$ _____), lawful money of the UNITED STATES OF AMERICA for the payment of which sum of money well and truly to be made, we bind ourselves, heirs, executors, administrators, successors and assigns, jointly and severally, firmly by these presents;

WHEREAS, The Principal has entered into a certain written Contract, dated _____

day of _____, 2016, with the _____ for _____

_____, as described in the foregoing Contract.

NOW THE CONDITIONS OF THIS OBLIGATION ARE SUCH that if the said Principal shall in all respects will and truly keep and perform the said Contract, and shall pay all sums of money due or to become due, for any labor, materials, apparatus, fixtures or equipment furnished for the purpose of construction of the work provided in said Contract, and shall remove and replace any defects in workmanship or materials which may be apparent or may develop within a period of one (1) year from the date of final acceptance, then this obligation shall be null and void; otherwise it shall remain in full force and effect.

And the said Surety, for value received, hereby stipulates and agrees that no change, extension of time, alteration or addition to the terms of the contract or to the work to be performed thereunder of the specifications accompanying the same shall in any way affect its obligation on this bond, and it does hereby waive notice of any such change, extension of time, alteration or addition to the terms of the contract or to the work or to the specifications.

IN WITNESS WHEREOF, we have hereunto set our hands and seal this _____

day of _____, 2016.

_____(SEAL)

_____(SEAL)

_____(SEAL)

_____(SEAL)

Principal

WITNESS:

(If Individual or Firm)

ATTEST:

(If Corporation)

_____(SEAL)

_____(SEAL)

Surety

ATTEST:

(Surety)

VILLAGE OF CAROL STREAM, IL

301 W. LIES ROAD

HISTORIC FARMHOUSE

EXTERIOR IMPROVEMENTS

Location Map (01/18/2016)



Farmhouse Elevation
301 W. Lies Road



1 SOUTH ELEVATION
 SCALE: 1/4" = 1'-0"



2 EAST ELEVATION
 SCALE: 1/4" = 1'-0"

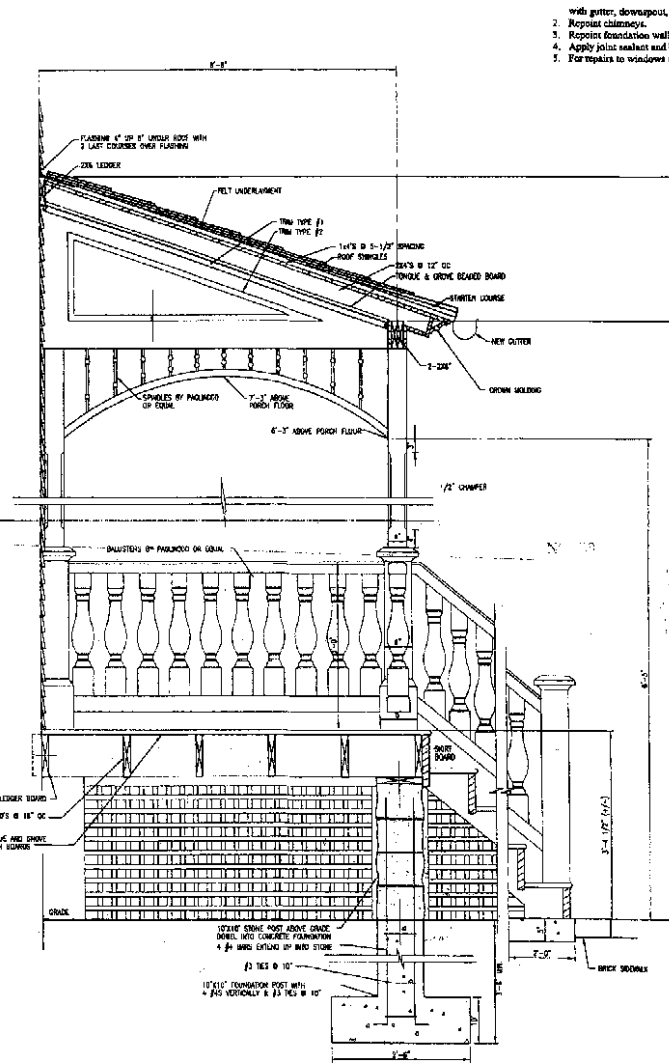

3 SECTION AT PORCH
 SCALE: 1" = 1'-0"

- with gutter, downspout, &
2. Repair chimney.
3. Repair foundation walls
4. Apply joint sealant and fl
5. For repairs to windows &

Village of Carol Stream
Interdepartmental Memorandum

MEMO TO: Joe Breinig, Village Manager
 FROM: Tia Messino, Management Analyst
 DATE: February 29, 2016
 SUBJECT: Motion to Approve Extension of Trees Removal Contract – 1-800 Tree Guy

In April of 2015, the Village awarded a contract to 1-800 Tree Guy for tree removal services following a public bidding process that attracted a total of thirteen (13) bids. The contract included the option to extend the contract for two, one-year terms. The only difference in pricing is a reduction in the cost of the 15.1” to 20” DBH, which decreases by \$30 to \$225 for FY 17 and FY 18.

1-800Tree Guy	<i>FY 16</i>	<i>FY 17</i>	<i>FY 18</i>
<i>Less than 5" DBH</i>	\$15	\$15	\$15
<i>5.0" TO 10" DBH</i>	\$64	\$64	\$64
<i>10.1" TO 15" DBH</i>	\$159	\$159	\$159
<i>15.1" TO 20" DBH</i>	\$255	\$225	\$225
<i>20.1" TO 25" DBH</i>	\$388.75	\$388.75	\$388.75
<i>25.1" TO 30" DBH</i>	\$513	\$513	\$513
<i>Over 30.1" DBH</i>	\$585	\$585	\$585
<i>Stump Only (Per inch)</i>	\$4	\$4	\$4

Public Works staff was satisfied with the performance and service 1-800 Tree Guy provided. The FY 17 proposed budget includes \$37,500 for removal of an estimated 150 trees throughout the year.

Staff recommends the Board approve a motion awarding a contract extension to 1-800 Tree Guy for tree removal services at an amount not to exceed \$37,500 for the period of May 1, 2016 through April 30, 2017.

Attachments

Village of Carol Stream
Interdepartmental Memo

TO: Mayor and Trustees
FROM: Joseph E. Breinig, Village Manager 
DATE: February 22, 2016
RE: Fourth of July Parade Donation

Annually the Village asks residents to donate money with their water bill payments to support the Fourth of July Parade. Money collected in one year is held and released the following year to the Parade Committee. A history of those donations follows:

2006	\$4,192.00
2007	\$4,337.00
2008	\$2,719.97
2009	\$3,724.48
2010	\$2,924.37
2011	\$2,787.70
2012	\$2,806.03
2013	\$1,940.53
2014	\$1,872.53
2015	\$1,893.49

A request from the Fourth of July Parade Committee for release of the donations is attached. Payment of \$1,893.49 is on the payables for the March 7, 2016, Village Board meeting.

JEB/dk

Attachment

cc: Fourth of July Parade Committee

To: Mayor and Village Board

From: Carol Stream July 4th Parade Committee

February 19, 2016

The Carol Stream July 4th Parade Committee requests the check from the Village from water bill donations.

The funds will be used to pay for parade expenses and performers for the 2016 parade. Performers invited for this year include: the Glenbard North High School Marching Band, the Jesse White Tumblers, Cruisin' Cooler Shrine Unit, the Barefoot Hawaiians, the St. Andrew's Society of Central Illinois Pipes & Drums, Mariachi Potosino band, stilt walkers and many others.

Let us know when it is on the agenda and we will attend the meeting.

Thanks

Kim Gieser
Chairperson, Carol Stream July 4th Parade Committee
630-681-7562

Village of Carol Stream
Interdepartmental Memo

TO: Joe Breinig, Village Manager

FROM: Philip J. Modaff, Director of Public Works 

DATE: March 1, 2016

RE: Recommendation for Purchase of Dump Truck

The FY17 budget includes funding for the replacement of truck #65, a large dump truck which serves primarily as an anti-icing unit and also supports street division activities in the summer months. The recommended purchase is for a cab and chassis along with the outfitting of the truck (dump body, plow, spreader, wet system and anti-icing unit).

The current vehicle was purchased in 1998 and is beyond the point where rehabilitation would be cost-effective. The dump body and frame are significantly corroded and it is not outfitted with updated snow and ice-fighting technology.

Last year at this time staff reviewed various vehicle offerings that meet our needs and subsequently purchased a Peterbilt model #348. We are again recommending this make and model and have found this truck available through a joint purchase contract awarded by Lake County (IL) Department of Transportation (joint purchasing agreement #15015). The contract document provides for other governmental agencies to purchase vehicles under the same terms of this contract, in accordance with the Governmental Joint Purchasing Act (30 ILCS 525/), similar to contracts available under the State's CMS program or the Suburban Purchasing Cooperative. The contract between Lake County and JX Peterbilt includes purchase of the cab and chassis directly from JX Peterbilt, who will then contract with another firm for outfitting of the truck. A copy of the proposal from JX Peterbilt is attached, along with the specifications associated with the contract between Peterbilt and Lindco Equipment Sales for the outfitting services.

When complete, this new truck will be outfitted with a stainless steel dump body and spreader, a wetting system, a corrosion-resistant aluminum cab, backup camera system and a large (11-foot) front plow. This truck will also come with a removable anti-icing unit, so that the truck can be used for anti-icing duties pre-storm and then be quickly switched over to plowing duties during a snow event.

The budget provides \$188,000 for this purchase. The total purchase price of the new truck would be \$180,917.96. Once received, we estimate up to \$1,000 additional will be spent on installation of a two-way radio and decals/stripping.

As reported at a recent budget workshop, portions of this truck will be painted with a custom pink color in recognition of breast cancer awareness. With the distinctive coloring the truck can be featured at community events (Relay for Life, July 4th Parade, WRC Open House, etc.) and be used to attract donations for appropriate fundraising interests.

While designing the truck with Peterbilt and Lindco, we also received voluntary commitments from various suppliers and vendors who want to support our efforts to increase breast cancer awareness. Below is a list of vendors who have offered to donate, discount or upgrade equipment on this truck:

Description	Vendor	Value
Dump body and tailgate spreader - polished stainless steel (upgrade)	Svenson	\$ 3,800
Backup camera and camera wash (donated)	MS Foster	\$ 1,027
20 - LED work, spreader and backup lights (donated)	ALT	\$ 578
Painting plow hitch/side boards - Susan G. Komen pink (donated)	Transport	\$ 944
Rear-wheel 1/4 fender covers (donated)	Lifetime	\$ 161
Wausau plow w/hitch (discounted 10%)	Wausau	\$ 1,236
Plow lights and harnessing (donated)	Hella	\$ 186
Hydraulic power system (discounted 25%)	Certified Power	\$ 4,800
Pressure relief coupling (donated)	CEJN	\$ 782
	TOTAL:	\$13,514

Staff is seeking approval to place the order prior to the start of the new fiscal year due to the long lead time in building the truck and the subsequent work to outfit the truck. By placing the order now staff expects to have the new truck built, outfitted and delivered before winter.

It is recommended that the Village Board approve a Motion to purchase a Peterbilt Model 348 from JX Peterbilt through Lake County DOT contract #15015 in the amount of \$180,917.96.

Attachments



42400 Hwy. 41, Wadsworth, IL. 60083

Date: 2-23-2016

To: Village of Carol Stream
124 Gerzevske Lane
Carol Stream, IL. 60188
Jason Pauling

LAKE COUNTY Joint Purchasing Agreement # 15015

Jason,

We are pleased to quote the following 2017 Peterbilt Model 348 as per the attached summary.

2017 Model 348	\$ 90,449.96
Doc Fee	\$ 168.00
Title / Plates	\$ 105.00
Heated Windshield	\$ 725.00
LINDCO Equipment w/ anti ice	\$ 89,470.00
TOTAL PACKAGE	\$ 180,917.96

Color - SUSAN G KOMEN Metallic PINK

Above Price good for all orders received on or before March 31,2016

Municipal FET and Sales Tax Exempt
Final Payment Due Upon Delivery
Signed Agreement Required
IDOR Tax Exempt Required

Rick Michalowski | Vocational Account Manager
JX Enterprises, Inc.
Cell 708-207-2354 | Fax 708-460-8991
rmichalowski@jxe.com
www.JXE.com

JX Peterbilt - Wadsworth P125
42400 Old Hwy 41

Village of Carol Stream
124 Gersevske Lane

Wadsworth, Illinois United States 60083
Phone: (847) 395-7222
Fax: (847) 395-7240
Email:

Carol Stream, Illinois United States
Phone: (630) 871-6269
Fax:
Contact Email: jpauling@carolstream.org
Prepared for: Jason Pauling

Vehicle Summary

	Unit		Chassis	
Model:		Model 348	Fr Axle Load (lbs):	20000
Type:		Full Truck	Rr Axle Load (lbs)	23000
Description:		Single Axle	G.C.W. (lbs):	43000
	Application		Road Conditions:	
Intended Serv.:		Snowplow	Class A (Highway)	100
Commodity:		Other Commodity	Class B (Hwy/Mtn)	0
	Body		Class C (Off-Hwy)	0
Type:		End Dump	Class D (Off-Road)	0
Length (ft):		10	Maximum Grade:	6
Height (ft):		11.5	Wheelbase (in):	178
Max Laden Weight (lbs):		3500	Overhang (in):	62.7
	Trailer		Fr Axle to BOC (in):	69.8
No. of Trailer Axles:		0	Cab to Axle (in):	108.2
Type:			Cab to EOF (in):	170.9
Length (ft):		0	Overall Comb. Length (in):	306
Height (ft):		0.0		
Kingpin Inset (in):		0	Special Req.	
Corner Radius (in):		0	United States Registry	
	Restrictions			
Length (ft):		40		
Width (in):		102		
Height (ft):		13.5		

Approved by: _____

Date: _____

Note: All sales are F.O.B. designated plant of manufacture.

	PacLease can help control costs and eliminate the challenges of owning, operating and maintaining your truck fleet. - Improve Operations - Preserve Capital for Growth - Stay Focused on Your Business
--	--

Unpublished options may require review/approval.
Dimensional and performance data for unpublished options may vary from that displayed in PROSPECTOR.

Printed:	2/25/2016 8:02:55 AM	Complete	Model Number:	Model 348
Effective Date:	Jan 1, 2016		Quote/DTPO/CO:	Q20212313
Prepared by:	ID: rmich		Version Number:	32.11

PETERBILT

JX Peterbilt - Wadsworth P125
42400 Old Hwy 41

Village of Carol Stream
124 Gersevske Lane

Wadsworth, Illinois United States 60083
Phone: (847) 395-7222
Fax: (847) 395-7240
Email:

Carol Stream, Illinois United States
Phone: (630) 871-6269
Fax:
Contact Email: jpauling@carolstream.org
Prepared for: Jason Pauling

Description

Base Model

Model 348
Other Commodity
Snowplow
Truck which is configured for mounting a snowplow to the front. May also have dump or other body.
End Dump
United States Registry

Configuration

Not Applicable
Secondary Manufacturer

Frame & Equipment

11-5/8in Steel Rails to 444in
11.625 x 3.874 x .375 Dimension, 2,568,000 RBM; Yield Strength: 120,000 psi. Section Modulus: 21.4 cubic inches. Weight: 1.91 lbs/inch pair
178in Wheelbase
Three-Piece Crossmembers
FEPTO Provision 27.8in Bumper Extension
Includes Crankshaft Adapter Plate and Stationary Grille. Requires FEPTO Bumper.
EOF Square without Xmbr
For use with body builder installed crossmember.
Omit Rear Mudflaps and Hangers

Front Axle & Equipment

Dana Spicer D2000F 20,000 lb, 3.5in Drop

Factory front axle alignment to improve handling & reduce tire wear. Zerk fittings on tie rod ends, king pins, & draglink ball joints for ease of maintenance & help extend service life of components. Cognis EMGARD® FE 75W-90 synthetic axle lube provides over 1% fuel economy improvement. Reduces wear & extends maintenance intervals, resulting in increased uptime. Provides improved fluid flow to protect components in extreme cold conditions & withstand the stress from high temperatures, extending component life.

Taper Leaf Springs, Shocks 20,000 lb
Standard with Heavy Resistance Shocks.

Power Steering Sheppard HD94 Dual
For use with 16,000 to 20,000 lb. axle ratings.

Power Steering Reservoir Frame Mounted w/Cooler

PHP10 Iron LMS Hubs-Air Disc

Air Disc Front Brakes
Complies with reduced stopping distance regulations.

Dust Shields, CAM And Air Disc Brakes, Front Axle

Gusseted Cam Brackets, Steer Axle

Rear Axle & Equipment

Dana Spicer S23-170 23,000 lb
Laser factory axle alignment to improve handling & reduce tire wear. Magnetic rear axle oil drain plug captures & holds any metal fragments in drive axle lube to extend service life. Parking brakes on all drive axles for optimal performance. Cognis EMGARD® FE 75W-90 synthetic axle lube provides over 1% fuel economy improvement. Reduces wear & extends maintenance intervals, resulting in increased uptime. Provides improved fluid flow to protect components in extreme cold conditions & withstand the stress from high temperatures, extending component life.

PHP10 Iron LMS Hubs
11-1/4" bolt circle. Includes a supplier extended coverage up to 3 years / 350,000 miles for bearings & seals.

Standard Stroke Parking Brakes
Drive Axle(s)

Dust Shields For Cam Brakes, Drive Axle(s)

Diff Lock Rear-Rear Or Single Drive Axle
(Air Rocker Switch occupies the space of one gauge)

Gusseted Cam Brackets, Drive Axle(s)

SBM Valve
Full trucks require a spring brake modulation (SBM) system for emergency braking application. This system requires an SBM valve and a relay valve with spring brakes on the rear axles. The SBM valve allows the foot valve to operate the rear axle spring brakes if a failure exists in the rear air system.

Stability System Not Selected or Not Available

Anti-Lock Braking System (ABS) 4S4M
ABS-6. Includes air braking system.

Synthetic Axle Lubricant All Axles
Peterbilt heavy duty models include Fuel Efficient Cognis EMGARD FE75W-90 which provides customers performance advantages over current synthetic lubricants with reduced gear wear and extended

maintenance intervals, resulting in increased uptime. In addition, the lubricant provides improved fluid flow to protect gears in extreme cold conditions and withstand the stress from high temperatures, extending component life.

Single Drive Axle (Model 348)

Bendix Air Cam Rear Drum Brakes 16.5x7

Inc automatic slack adjusters & outboard mounted brake drums.

Ratio 6.83 Rear Axle

Peterbilt Air Trac 23,000 lb Light Weight

Dash Mtd Dump Switch With Indicator Light

For suspension

Engine & Equipment

PACCAR PX-9 300@2000 GOV@2200 860@1300

(2013 Emissions) Includes alum flywheel housing, cruise control, and J1939 provisions (provides an interface point for the Electronic Service Analysis-ESA and other PACCAR approved diagnostic tools). Chevron Delo LE SAE 10W30 engine oil is specially formulated for new low emissions engines. Magnetic engine oil drain plug captures and holds any metal fragments in engine oil to extend service life.

N21320 N205 120..Standard Maximum Speed Limit [LSL]

N21330 N207 0....Expiration Distance

N21340 P005 120..Hard Maximum Speed Limit

N21350 P001 64...Maximum Accelerator Pedal Vehicle Speed

N21360 P110 0....Accelerator Lower Droop

N21370 P059 64...Maximum Cruise Speed

N21380 P111 0....Cruise Control Lower Droop

N21400 N203 252..Reserve Speed Function Reset Distance

N21410 N202 0....Maximum Cycle Distance

N21420 N206 10...Maximum Active Distance

N21430 N201 0....Reserve Speed Limit Offset

N21440 P015 No...Engine Protection Shutdown

N21450 P026 No...Gear Down Protection

N21460 P046 1400.Max PTO Speed

N21470 P062 No...Cruise Control Auto Resume

N21480 P068 No...Auto Engine Brake in Cruise

N21500 N209 0....Expiration Distance

N21510 P520 Yes..Enable Idle Shutdown Park Brake Set

N21520 P030 15...Timer Setting

N21530 P233 Yes..Enable Impending Shutdown Warning

N21540 P234 60...Timer For Impending Shutdown Warning

N21550 P516 35...Engine Load Threshold

N21570 P031 No...Idle Shutdown Manual Override

N21590 P230 Yes..Enable Hot Ambient Automatic Override

N21610 P172 40...Low Ambient Temperature Threshold

N21620 P173 60...Intermediate Ambient Temperature Threshold

N21630 P171 80...High Ambient Temperature Threshold

Engine Idle Shutdown Timer Enabled

Enable EIST Ambient Temp Override

Eff EIST NA Expiration Miles

Effective VSL Setting NA

Belly Pan

CARB Engine Idling Compliance

PACCAR PX-7, PX-9 and MX, Cummins ISL, ISM and ISX diesel engines will include the required factory installed serialized sticker on the drivers door to identify them as meeting the NOx idling standard.

PACCAR 160 Amp Alternator, Brushed

Immersion Type Block Heater 110-120V

Standard location is center left hand under cab and includes a weather-proof cover that protects the receptacle. This pre-heater keeps the coolant in the engine block from freezing when the engine is not running.

PACCAR 12V Starter

3 PACCAR Premium 12V Dual Purpose Batt 2100 CCA

Threaded stud type terminal. Stranded copper battery cables are double aught (00) or larger to reduce resistance.

Battery Jumper Terminal Mounted Under Hood

LH Frame Rail. Not available with PX-7 engines.

2-Speed Fan Clutch For Frequent Start/Stops

18.7 CFM Air Compressor

Furnished on engine. Teflon lined stainless steel braided compressor discharge line.

Spin-On Fuel Filter/Water Separator, 12V Heated

Frame Mounted. In addition to the fuel filter supplied with the engine. Includes fuel water separator on Models 330, 337, and 348.

High Efficiency Cooling System

Cooling module is a combination of steel and aluminum components, with aluminum connections to maximize performance and cooling capability. Silicone radiator & heater hoses enhance value, durability, & reliability. Constant tension band clamps reduce leaks. ClimaTech extended life coolant extends maintenance intervals which reduces maintenance costs. Anti-freeze effective to -30 degrees F helps protect the engine. Low coolant level sensor warns of low coolant condition to prevent engine damage. Radiator Size by Model: 587: 1330 sq in, 579/367 FEPTO 1325 sq in, 567/365/367: 1440 sq in, 384/386: 1301 sq in, 365 FEPTO: 1184 sq in, 389/367 HH: 1669 sq in, 348: 1000 sq in, 320: 1242 sq in.

Radial Seal, Dry Type Air Cleaner, Frontal

Air Intake. Molded rubber air intake connections with lined stainless steel clamps seal to prevent contaminants in air intake.

Exhaust Single RH Side Of Cab

DPF/SCR RH under cab. Includes cab entry RH under cab and full round stainless steel exhaust guard.

Curved Tip Standpipe(s)

18in Ht, 5in Dia Chrome, Clear Coat Standpipe(s)

Transmission & Equipment

Allison 3000 RDS-P Transmission, Gen 5

Rugged Duty Series. Includes Rear Transmission Support, TranSynd Automatic Transmission Fluid, and Water Oil Heat Exchange. Also includes features that monitor the transmission fluid, filter and clutch condition. Will display percent life remaining for the transmission fluid, filter and clutches on the shift selector. This information may be displayed using the Mode and Up and Down buttons. A wrench icon will also be included to indicate when the transmission fluid, filter or clutches need servicing. (Suited for vehicles operating on/off highway and/or requiring PTO operation) Forward Ratios: 1st-3.49, 2nd-1.86, 3rd-1.41, 4th-1.00, 5th-

0.75, 6th-0.65 / Reverse Ratios: DR-(5.03)

1710 HD Driveline, 1 Midship Bearing

Programming Allison Snowplow

Primary shift 1 and shift 2, secondary shift schedule fixed 2 (no LBSS)

Allison FuelSense Not Desired

Allison 6-Speed Configuration, Close Ratio Gears

3000 Series Transmissions

Seat Mounted Lever Shifter

Air & Trailer Equipment

Bendix AD-IS Air Dryer with Heater

An integrated system air dryer that incorporates the functions of the air dryer, purge reservoir (which increases the drying capacity), wet air tank, pressure relief valve, single check valves, and pressure protection valve for air susp and other air accessories. Includes easy-to-service spin-on dessicant cartridge.

Berg Pull Cord Drain Valve(s) - All Air Tanks

Nylon Chassis Hose

Steel Painted Air Tanks

All air tanks are steel with painted finish except when Code 4543330 Polish Aluminum Air Tanks is also selected (then exposed air tanks outside the frame rails will be polished aluminum). Peterbilt will determine the optimal size and location of required air tanks. Narratives requesting a specific air tank size or location will not be accepted for factory installation. See ECAT to determine number or location of air tanks installed.

High Mount Air Tanks BOC/BOS Where Possible

Subject to frame review.

7-Way Electric Harness with Socket Mounted EOF

Body Connections 5ft BOC

Junction Box contains light and power circuits for Body Connections located 5ft from BOC.

Tires & Wheels

FF: GY 20Ply 315/80R22.5 Endurance WHA

RR: GY 14ply 11R22.5 G182 RSD

Diameter = 42.1 inches; SLR = 19.6 inches

Code-rear Tire Qty 04

FF: Alcoa 894657 LVL1 22.5X9.00 Alum Wheel

Pilot Mount

RR: Alcoa 885657 LvL1 PLT 22.5X8.25

Aluminum wheel severe service.

Code-rear Rim Qty 04

FF: Polish Wheels, Outer Surface, SGL/TDM Steer

Polish outer surface of outer wheel. Without chrome wheel nuts.

RR: Polish Wheels, Outer Surface, Single Drive

Without chrome wheel nuts. Polish outer surface of outer wheel.

FF: Dura-Bright Finish

Outer Surface of Outer Wheel, Includes Wheel Guards, Requires Polished Option

Fuel Tanks

26in Aluminum 70 Gallon Fuel Tank LH U/C

Includes steps for cab access. Paddle handle filler cap with threadless filler neck. Top draw fuel plumbing reduces chance of introducing air into the fuel system during low fuel level conditions due to the central placement of fuel pickup tube. Wire braid fuel lines increase durability & reduce potential for leaks.

Location LH U/C 70 Gallon

Polish (1) Aluminum Fuel Tank

Polish All Fuel / Hydraulic Tank Straps

Does not apply to Rectangular Def Tank straps.

DEF Tank Mounted LH BOC

Models 210, 220 and 320 mounted LH cab fender.

Standard DEF To Fuel Ratio 2:1 Or Greater

Polished Stainless Steel Cover For DEF Tank

DEF Tank Small

Battery Box & Bumper

Aluminum Space Saver Battery Box RH BOC

Battery Access From Side

Rubber Battery Pad In Bottom Of (1) Battery Box

(Mat in box that holds batteries only)

Aftertreatment RH U/C Alum Non-Slip Cab Entry

Step. DPF/SCR for diesel engines, catalyst for natural gas engines. On

Models 579 specifying chassis fairings, the box will be aerodynamic.

Steel Bumper Swept Back Painted Black, FEPTO only

With two tow pin holes and step plates on top of bumper.

Cab & Equipment

Alum Cab 108in BBC Metton Hood w/Bright Crown

Includes view window RH door and convex mirror over RH door.

Severe Service Cab Package #1

Includes Aluminum side skins, aluminum rear skin, steel windshield mask, steel firewall, and steel front floor sheet on all cabs, and additional reinforcement structure on the back wall of the day cab.

Thermal Insulation Package in Cab

Includes thick, closed-cell foam in floor, special mylar-faced foam in walls and roof structure.

Rubber Fender Lips 2 Inch Wide

Peterbilt UltraRide Driver Seat

Peterbilt UltraRide Passenger Seat

Passenger Armrest - LH only

Required with Evolution LX seats, optional with Evolution ST Seats.

Black Seat Color ipo Standard Color

Air Ride Driver

High Back Driver

Vinyl Driver

Non-Air Ride Passenger

High Back Passenger

Vinyl Passenger

Adjustable Steering Column - Tilt/Telescope

Steering Wheel with Peterbilt Logo

Steering Wheel with embossed Peterbilt logo over horn button.

Interior Grey/Black

Includes rugged charcoal instrument panels, glare-resistant gray dash, black bezels on gauges, (2) power ports, monochromatic molded door pads with durable in-mold color, gray molded back wall, 18 inch 4-spoke soft-touch steering wheel, soft-touch steering column cover, power lift passenger window, extruded rubber floor covering, header-mounted dome light, foot well lighting, integrated "dead pedal", (4) inside entry grab handles, (2) inside sunvisors, (2) coat hooks, (2) cup holders and map bin in dash.

Extended Rear Window ipo Std Window-Day Cab

The extended rear window protrudes two inches more than the standard conventional rear cab window. Take this into consideration when determining your loadspace.

Day Cab Rear Window

One Piece Curved Windshield

Combo Fresh Air Heater/Air Conditioner

With radiator mounted condenser, dedicated side window defrosters, Bi-Level Heater/Defroster Controls, 54,500 BTU/HR, and silicone heater hoses.

Cup Holder (Floor Mounted)

Includes two standard-size drink holders and one extra-large jugholder, coin tray, and clipboard-size storage area.

Outside Sunvisor - Stainless Steel

Not available with 2.1M high roof sleeper.

Aero Mirrors Ea Side Htd & Mtrzd 4-Way Adjustable

Bright Finish with Convex

Power Package

Includes power door locks and power windows.

(2) Air Horns 24.5in Chrome - Round w/Horn Shield

Standard Speaker Package For Cab

(2) Speakers

ConcertClass Without CD, Includes BT Phone and

Audio, AM/FM, WB, USB and MP3.

CB Terminals/Wiring Mtd Under Header

Radio Antenna Mounted on LH Mirror Bracket

Plug-In Auto Reset Circuit Breaker

in place of fuses in junction box.

Peterbilt Electric Windshield Wipers

With Intermittent Feature.

CabMate Cab Air Suspension

Mfg by Link. The class 8 conventionals (except Model 348) includes (2) airbags, (2) shock absorbers, (1) leveling valve, radius rod, and height limiter. The Models 330, 337, and 348 includes (1) airbag and (1) shock absorber.

Backup Alarm (107dB)

Air Restriction Indicator

Mounted on air cleaner or intake piping.

Bright Bezel Gauges

(2) Additional Electric Switches Without Wiring

Main Instrumentation Panel, Graphics Display

Includes speedometer with tripodometer, tachometer with hourmeter and

outside air temperature display, voltmeter, engine oil pressure, engine coolant temperature, fuel level, primary and secondary air pressure gauges. Includes standard warning light package: high water temperature, low oil pressure, and low air pressure warning lights w/audible alarms, high beam, turn signal, low fuel, parking brake, and ice warning indicators; seat belt reminder; rocker switches with long-life LED indicators; multi-function turn stalk with flash-to-pass feature (night mode flashes headlights and marker lights; day mode flashes headlights only), intermittent windshield wiper and headlamp beam control. Hydraulic braked trucks do not include air pressure gauges.

Headlights Composite Fender Mounted

Integral Park, Turn, and Side Marker

(5) Marker Lights, Bus LED Bullet

Light Emitting Diodes

(2) SSTL Brkts Roof Mounted F/O Beacon/Strobe

Lights. Mounted above each door toward rear - Includes switch and wiring.

(2) Addl Dome/Reading Lights, Ceiling Mounted

Paint

(1) Color Axalta Two Stage - Cab/Hood

Base Coat/Clear Coat

N85020	A -	890524EY	SUSAN G KOMEN
N85400	HOOD TOP	890524EY	SUSAN G KOMEN
N85500	CAB ROOF	890524EY	SUSAN G KOMEN
N85200	FRAME	N0001EA	BLACK
N85700	BUMPER	N0001EA	BLACK
N85300	FENDER	890524EY	SUSAN G KOMEN

Axalta Two Stage Effect - Metallic/Pearl

Cab/Hood & Sleeper Only

Options Not Subject To Discount

Medium Duty Emissions Surcharge

Miscellaneous

Presentation Created Using Featured Spec

For Model

Total Weight

12295

Prices and Specifications Subject to Change Without Notice.

Unpublished options may require review/approval.

Dimensional and performance data for unpublished options may vary from that displayed in PROSPECTOR.

Printed:	2/25/2016 8:02:55 AM	Complete	Model Number:	Model 348
Effective Date:	Jan 1, 2016		Quote/DTPO/CO:	Q20212313
Prepared by:	ID: rmich		Version Number:	32.11

LINDCO

Equipment Sales, Inc.

2168 East 88th Drive
Merrillville, IN 46410
USA

QUOTATION

Quote Number: 160194
Quote Date: Mar 1, 2016
Page: 1

Voice: (219)795-1448
Fax: (219)736-0892

Visit Lindco's new webstore @ www.lindco-usa.com
Now accepting Visa and Mastercard

Quoted To:

JX Peterbilt
2203 Bernice Rd.
Lasing, IL 60438
USA

Customer ID	Good Thru	Payment Terms	Sales Rep
JX-01	3/31/16	Prepaid	358-78

Quantity	Item	Description	Unit Price	Amount
1.00		EQUIPMENT FOR PETERBILT SINGLE AXLE PLOW TRUCK	74,908.00	74,908.00
		THE FOLLOWING ITEMS MUST BE FURNISHED BY THE TRUCK MANUFACTURER:		
		* FRONT FRAME EXTENSIONS.		
		* CHASSIS BODY BUILDER WIRING HARNESS TO END OF TRUCK FRAME.		
		* CHASSIS PLOW LIGHT HARNESS WITH SWITCH IN DASH		
		* 103" CAB TO AXLE		
		* WIRE FOR HOOKING UP GROUND SPEED		
		* BUCKET SEATS IN CAB		
		* MINIMUM OF 22" CLEARANCE UNDER CAB AND BACK TO REAR AXLE ON BOTH SIDES.		
		* MINIMUM OF 46" CLEARANCE FROM BACK OF CAB TO REAR FRONT SPRING SHACKLE ALONG FRAME ON DRIVE SIDE		
		* HORIZONTAL EXHAUST WITH VERTICAL STACK ON CURBSIDE		
		* TRANS DIPSTICK LOCATED ON PASSENGER SIDE.		
		DELIVERY NOTES:		

Quote valid for 30 days.

Subtotal	Continued
Sales Tax	Continued
TOTAL	Continued

LINDCO

Equipment Sales, Inc.

2168 East 88th Drive
Merrillville, IN 46410
USA

QUOTATION

Quote Number: 160194
Quote Date: Mar 1, 2016
Page: 2

Voice: (219)795-1448
Fax: (219)736-0892

Visit Lindco's new webstore @ www.lindco-usa.com
Now accepting Visa and Mastercard

Quoted To:

JX Peterbilt
2203 Bernice Rd.
Lasing, IL 60438
USA

Customer ID	Good Thru	Payment Terms	Sales Rep
JX-01	3/31/16	Prepaid	358-78

Quantity	Item	Description	Unit Price	Amount
1.00	SSM1-103036-BT	<p>* Allow 150 days for all equipment to be in stock at Lindco after receiving your purchase order. * Allow 60 days to complete unit, once all equipment and chassis are in stock at Lindco. * Estimated delivery date is currently September 30, 2016.</p> <hr/> <p>DUMP BODY:</p> <hr/> <p>Swenson 10' x 7', 6/8 yd dump body, front telescopic hoist less hyd, 1/4" Hardox 450 floor, 7 gauge 201 SS 4B bal., 30"sides, 36" TG, 1/2 CS, * 10' long * 84" wide I.D. * 96" wide O.D. * 48" high front wall * 30" high sides (6 cu. yds.) * 36" high tailgate (8.2 cu. yds.) * 3/16 (201 SS 4B FINISH) sides, front wall and tailgate * 1/4" Hardox 450 floor * Air release 2-panel double-acting tailgate (201 SS) * 1/2 cab shield (201 SS), fully enclosed w/16 total ovals facing front, back & side. * Boxed top rail, sloping rub rail, no side braces (201 SS)</p>		

Quote valid for 30 days.

Subtotal	Continued
Sales Tax	Continued
TOTAL	Continued

LINDCO

Equipment Sales, Inc.

2168 East 88th Drive
Merrillville, IN 46410
USA

QUOTATION

Quote Number: 160194
Quote Date: Mar 1, 2016
Page: 3

Voice: (219)795-1448
Fax: (219)736-0892

Visit Lindco's new webstore @ www.lindco-usa.com
Now accepting Visa and Mastercard

Quoted To:

JX Peterbilt
2203 Bernice Rd.
Lasing, IL 60438
USA

Customer ID	Good Thru	Payment Terms	Sales Rep
JX-01	3/31/16	Prepaid	358-78

Quantity	Item	Description	Unit Price	Amount
1.00		* 17" wide full depth rear corner post w/rear apron (201 SS)		
		* Rear corner posts are fully-enclosed w/removal access panel underneath on each side		
		* Three (3) oval cutouts in each rear corner post (sloped)		
		* Crossmemberless understructure		
		* CS90-4.5-3DA telescopic front mounted hoist, double-acting (power up & power down)		
		* Body hoist prop		
		* Grab handle at front on driver side (201 SS)		
		* Stainless steel fold up ladder on driverside		
		* Stainless steel handles on upper tailgate pins		
		* Stainless steel tailgate chains		
		* Special stainless steel custom light boxes on each corner post		
		* All SS TG hardware & linkage		
		* Overcenter kit for air TG		
1.00		Lindco 10" high oak side boards, painted PINK		
1.00	MD2430	DuraGuard 3/8" HD 24" x 30" Guard Mud Flap - Black - with Lindco Equipment Sales, Inc. Logo & Merrillville, IN molded PINK/white into flap (price per pair)		
2.00	MFBH2375A-SS	Lindco Mud Flap 90 Degree Mounting Plate-Stainless Steel (Each)		
2.00	MFW2375-SS	Lindco Mud Flap Bolting Plate-Stainless Steel (Each)		
1.00	SS212PA2	Life-Time Fender stainless steel 1/4 fender kit, one		

Quote valid for 30 days.

Subtotal	Continued
Sales Tax	Continued
TOTAL	Continued

LINDCO

Equipment Sales, Inc.

2168 East 88th Drive
Merrillville, IN 46410
USA

Voice: (219)795-1448
Fax: (219)736-0892

QUOTATION

Quote Number: 160194
Quote Date: Mar 1, 2016
Page: 4

**Visit Lindco's new webstore @ www.lindco-usa.com
Now accepting Visa and Mastercard**

Quoted To:
JX Peterbilt
2203 Bernice Rd.
Lasing, IL 60438
USA

Customer ID	Good Thru	Payment Terms	Sales Rep
JX-01	3/31/16	Prepaid	358-78

Quantity	Item	Description	Unit Price	Amount
		bolt mount (per pair)		
		ELECTRICAL & LIGHTING ITEMS:		
1.00	101004	Velvac Solenoid Operated Tailgate Lock Kit w/solenoid valve, 3.5" I.D. x 6" stroke air cylinder, clevis hardware, faceplate.		
1.00	510	Ecco back-up alarm, 97 dB, 12 VDC.		
1.00		* LED S/T/T lights, ICC lights, reflectors and harness		
1.00	01-0684859-41	Whelen 72" Justice lightbar, LED w/8" mounting feet.	1,504.36	1,504.36
1.00	02-0484859-20	Whelen worklights installed in 72" Justice lightbar.	289.64	289.64
2.00	T1903595	ALT 6" oval backup, class 1 LED. Includes grommet & pigtail.		
16.00	F1914101	ALT 6" oval amber, class 1 LED. Includes grommet & pigtail.		
1.00	996174051	Hella C220 combination plow lamp, LH pedestal surface, stud mount.		
1.00	996174061	Hella C220 combination plow lamp, RH pedestal surface, stud mount.		
2.00	H84985451	Hella pigtail 355mm w/6 pin DT connector.		
1.00	PLB11SS	Buyers stainless steel plow light brackets.		
2.00	W0904500	ALT LED worklight, Par36, 27 watts, 2150 Lumen, black aluminum housing, SPOT light.		
1.00	593083	Velvac 7-Way Pin Type Socket		
1.00	SWM 43C	Preco Switch, water resistant, 5 amp rating, 360 degree movement, can be wired open or closed,		

Quote valid for 30 days.

Subtotal	Continued
Sales Tax	Continued
TOTAL	Continued

LINDCO

Equipment Sales, Inc.

2168 East 88th Drive
Merrillville, IN 46410
USA

QUOTATION

Quote Number: 160194
Quote Date: Mar 1, 2016
Page: 5

Voice: (219)795-1448
Fax: (219)736-0892

Visit Lindco's new webstore @ www.lindco-usa.com
Now accepting Visa and Mastercard

Quoted To:

JX Peterbilt
2203 Bernice Rd.
Lasing, IL 60438
USA

Customer ID	Good Thru	Payment Terms	Sales Rep
JX-01	3/31/16	Prepaid	358-78

Quantity	Item	Description	Unit Price	Amount
2.00	055060	made of ABS plastic, adjustable mounting bracket.		
1.00	131-0011	Velvac Electrical Junction Box		
1.00		TST 80 amp high amp circuit breaker.		
1.00		All wiring in "CarFlex" Heavy Duty conduit/loom		
5.00	82-2313	Grote Terminal Strip, 8 Stud		
<hr/>				
PINTLE HOOK:				
<hr/>				
1.00		5/8" Pintle hook plate		
		* Recess chassis S/T/T light into pintle hitch		
		* Wrap pintle hitch		
1.00	PH20	Buyers 20 ton rigid mount pintle hook		
2.00	B46	Buyers 3/4" drop forged D-ring w/weld bracket 4-1/2" x 4-1/2" O.D.		
1.00	49122	Grote SuperNova thin-line LED red bar lamps.		
1.00	60321	Grote license lamp w/stainless steel bracket.		
1.00	B2800A	Buyers Heavy Duty Tow Hooks (27,000# capacity) - Pair		
<hr/>				
HYDRAULIC SYSTEM & PRE-WET SYSTEM:				
<hr/>				
1.00		Certified Power SPECIAL DISCOUNTED hydraulic system, complete w/the below hydraulic components.		
1.00	CPTO 280GGFJW-B8RF	Chelsea Hot Shift Wet Spline PTO for direct mounted pump with rotating flange		
1.00	SDPP 83015158	Certified Power Load Sense Pump SDPP		

Quote valid for 30 days.

Subtotal	Continued
Sales Tax	Continued
TOTAL	Continued

LINDCO

Equipment Sales, Inc.

2168 East 88th Drive
Merrillville, IN 46410
USA

QUOTATION

Quote Number: 160194
Quote Date: Mar 1, 2016
Page: 6

Voice: (219)795-1448
Fax: (219)736-0892

Visit Lindco's new webstore @ www.lindco-usa.com
Now accepting Visa and Mastercard

Quoted To:

JX Peterbilt
2203 Bernice Rd.
Lasing, IL 60438
USA

Customer ID	Good Thru	Payment Terms	Sales Rep
JX-01	3/31/16	Prepaid	358-78

Quantity	Item	Description	Unit Price	Amount
1.00	RESE MTCA3301000106	JRR060BLS1424NNN3A3N4DBNNNNNNNNN Certified Power 3 spool manual PVG32, SS reservoir/valve assembly with auger/spinner/prewet/anti-ice manifold.		
1.00	HBV200	Buyers 2" Ball Valve - Full Flow		
1.00	ELCA FR6110003	Certified Power FXDS console w/3 lane anti-icing controller.		
1.00	4276	Certified Power TPE wiring harnesses to run 3 lane Anti-Icing unit		
3.00	WESC 51461-096I	Certified Power 8' RVC Cable.		
1.00	WESC 08-5920-06-R	Wescon dual axis control w/one (1) momentary blast button & one (1) momentary spot button.		
1.00	WESC 08-6002-02	Wescon Single Axis Control w/center locking & 70 degree offset.		
1.00	2001370	TST Control Console Panel Assembly with Back Lighting. Switches for Plow lights, Pump, Top Warn Light, Rear Warn Light, Spreader Lit, Aux. & Body up Light		
1.00	9800576-1	TST Control Console Panel Assembly 2-5/8" Spacer		
1.00	9800576-2	TST Control Console Panel Assembly 1-3/16" Spacer		
3.00	RESE MT03139516	Certified Power PVG32 Clevis Kit for valve/service guard		
1.00	MORS RVC-DECAL-1	Morse control decal for CT-SA-1 & CT-DA-2		
1.00	LISC SG06070056	Certified Power prewet, valve instack w/flow meter.		
1.00	LISC SG06080019	Certified Power 240 gallon behind the cab prewetting system. Includes (2) 120 gallon tanks, stainless		

Quote valid for 30 days.

Subtotal	Continued
Sales Tax	Continued
TOTAL	Continued

LINDCO

Equipment Sales, Inc.

2168 East 88th Drive
Merrillville, IN 46410
USA

QUOTATION

Quote Number: 160194
Quote Date: Mar 1, 2016
Page: 7

Voice: (219)795-1448
Fax: (219)736-0892

Visit Lindco's new webstore @ www.lindco-usa.com
Now accepting Visa and Mastercard

Quoted To:

JX Peterbilt
2203 Bernice Rd.
Lasing, IL 60438
USA

Customer ID	Good Thru	Payment Terms	Sales Rep
JX-01	3/31/16	Prepaid	358-78

Quantity	Item	Description	Unit Price	Amount
1.00	LISC SG06090028	mounting frame, hold down straps and mounting hardware.		
1.00	ELCA SG07070122	Certified Power prewet plumbing kit, behind cab, 1 line, 2 nozzles		
1.00	ELCA SG07010269	Certified Power Poly Float with BH Corded Plug		
1.00	ELCA 849-1262-003	Certified Power Low oil shutdown kit for PTO		
1.00	00002 332 39	Certified Power "Roadwatch" kit sensor & display.		
1.00	00002 332 09	Swenson V-box flush kit		
1.00		Swenson 1-1/2" female quick fill kit		
1.00		Hoses & fittings, Stainless tubing to front & stainless tubing to rear.		
1.00	10-932-4001	CEJN Multi-X Quattro 12.5 Female Plate, 4 port, WEO 3/4" connection, 1/2" nominal flow diameter, dust caps, and , mounting bracket		
1.00	10-932-4051	CEJN Multi-X Quattro 12.5 Male Plate, 4 port, WEO 1/2" connection, 1/2" nominal flow diameter, dust caps, and , mounting bracket		
4.00	14-727-0812	CEJN Multi-X adapter 1/2" WEO to male JIC 3/4"-16		
4.00	14-727-1217	CEJN Multi-X adapter 3/4" WEO to male JIC 1-1/16"-12		
1.00	10-932-1023	CEJN Multi-X Quattro aluminum cover/parking dock, female		
1.00	10-932-1074	CEJN Multi-X Quattro aluminum cover/parking dock with mounting bracket, male		
1.00		Sleeve all hoses in stainless steel sleeving w/heat shrink ends		

Quote valid for 30 days.

Subtotal	Continued
Sales Tax	Continued
TOTAL	Continued

LINDCO

Equipment Sales, Inc.

2168 East 88th Drive
Merrillville, IN 46410
USA

QUOTATION

Quote Number: 160194
Quote Date: Mar 1, 2016
Page: 8

Voice: (219)795-1448
Fax: (219)736-0892

Visit Lindco's new webstore @ www.lindco-usa.com
Now accepting Visa and Mastercard

Quoted To:

JX Peterbilt
2203 Bernice Rd.
Lasing, IL 60438
USA

Customer ID	Good Thru	Payment Terms	Sales Rep
JX-01	3/31/16	Prepaid	358-78

Quantity	Item	Description	Unit Price	Amount
40.00	Hydraulic Oil	Hydraulic Oil		
		SNOW PLOW & PLOW HITCH:		
1.00		Reuse Peterbilt bumper		
1.00	HSP4211-H-SQH-BT	Wausau HomeSafe Trip Edge Snowplow, black polymer moldboard & PINK frame, PR w/cushion valve, Schmidt Quick Hitch, 5/8" edge w/carbides, plow markers,		
1.00	3512144	"Lindco" Snow Deflector 12"		
		SALT SPREADER:		
1.00	00002-463-100	Swenson SADS tailgate spreader w/18" poly spinner, direct drive, 6" auger, stainless steel construction, no paint, sides of spreader 8" higher.		
1.00		Short Hose Kit		
1.00		Stainless steel spray bar installed in auger trough		
1.00		For Swenson LA1000 Anti-Icing unit. 1000 gallon capacity, SS leg stand kit, anti-icing pump, lane valves, TG latch bar,	12,768.00	12,768.00
		CAMERA & CAMERA WASH SYSTEM:		
1.00	A3397	Brigade color camera kit complete with VBV-770D-000N 7" LCD color monitor, VBV-701C		

Quote valid for 30 days.

Subtotal	Continued
Sales Tax	Continued
TOTAL	Continued

LINDCO

Equipment Sales, Inc.

2168 East 88th Drive
Merrillville, IN 46410
USA

Voice: (219)795-1448
Fax: (219)736-0892

QUOTATION

Quote Number: 160194
Quote Date: Mar 1, 2016
Page: 9

Visit Lindco's new webstore @ www.lindco-usa.com
Now accepting Visa and Mastercard

Quoted To:

JX Peterbilt
2203 Bernice Rd.
Lasing, IL 60438
USA

Customer ID	Good Thru	Payment Terms	Sales Rep
JX-01	3/31/16	Prepaid	358-78

Quantity	Item	Description	Unit Price	Amount
1.00	A1386	color camera and 66' cable		
1.00	MSF8470037000	Brigade 33' camera cable		
1.00	MSF5000CAM "U"	Camera Wash (1) nozzle		
1.00	MSF5010	Camera box for camera stainless steel w/"U" pivot bracket.		
1.00	MSF5010	Camera Wash 30' tubing kit complete with air and washer		
PAINT & UNDERCOATING:				
1.00	PAINT PINTLE HITCH	Paint Pintle Hitch		
1.00	PAINT HOIST & SUBFRA	Prime Where needed and Paint Hoist & Subframe to black		
1.00	PAINT PLOW HITCH	Paint Plow Hitch, Including lift arm, side plates, bumper and lift cylinder PINK		
1.00	PAINT SIDE BOARDS	Paint Wood Side Boards PINK		
1.00	PAINT-MISCEL	Paint Miscel		
1.00	Under Coat	Under coat dump body		
INSTALLATION, MISCELLANEOUS MATERIAL AND FREIGHT:				
2,459.00	Misc.	Miscellaneous Material - includes any or all of the following: wiring, electrical connectors, tie downs, clamps, nut, bolts, washers, steel, oil, grease, etc.		
2,500.00	FREIGHT	FREIGHT		

Quote valid for 30 days.

Subtotal	Continued
Sales Tax	Continued
TOTAL	Continued

LINDCO

Equipment Sales, Inc.

2168 East 88th Drive
Merrillville, IN 46410
USA

QUOTATION

Quote Number: 160194
Quote Date: Mar 1, 2016
Page: 10

Voice: (219)795-1448
Fax: (219)736-0892

Visit Lindco's new webstore @ www.lindco-usa.com
Now accepting Visa and Mastercard

Quoted To:

JX Peterbilt
2203 Bernice Rd.
Lasing, IL 60438
USA

Customer ID	Good Thru	Payment Terms	Sales Rep
JX-01	3/31/16	Prepaid	358-78

Quantity	Item	Description	Unit Price	Amount
236.00	INSTALLATION	Lindco Installation Labor Hours *ALL ITEMS PAINTED AND MOUNTED COMPLETE PRICING DOES NOT INCLUDE PICKUP OR DELIVERY OF THE TRUCK. BREAST CANCER AWARENESS DONATED/DISCOUNTED ITEMS:		
1.00		Dump body & TG spreader will be built out of 4B polished stainless at no additional charge, a savings of \$3,800.00.		
2.00		Backup camera system & camera wash will be provided to Lindco @ N/C, a savings of \$1,027.00.		
3.00		LED work lights, LED backup lights & LED spreader lights, totaling (20) lights will be provided to Lindco at N/C, a savings of \$578.00.		
4.00		Painting of plow hitch & side boards PINK, painting of pintle hitch & subframe black will be provided to Lindco @ N/C, a savings of \$944.00.		
5.00		SS 1/4 fender kit will be provided to Lindco @ N/C, a savings of \$161.00.		
6.00		Wausau plow with SQH hitch discounted an additional 10%, a savings of \$1,236.00.		
7.00		Hella plow lights & harnessing supplied to Lindco @ N/C, a savings of \$186.00.		

Quote valid for 30 days.

Subtotal	Continued
Sales Tax	Continued
TOTAL	Continued

LINDCO

Equipment Sales, Inc.

2168 East 88th Drive
Merrillville, IN 46410
USA

QUOTATION

Quote Number: 160194
Quote Date: Mar 1, 2016
Page: 11

Voice: (219)795-1448
Fax: (219)736-0892

**Visit Lindco's new webstore @ www.lindco-usa.com
Now accepting Visa and Mastercard**

Quoted To:
JX Peterbilt
2203 Bernice Rd.
Lasing, IL 60438
USA

Customer ID	Good Thru	Payment Terms	Sales Rep
JX-01	3/31/16	Prepaid	358-78

Quantity	Item	Description	Unit Price	Amount
8.00		Certified Power hydraulic system, includes pump/PTO/valve/reservoir/behind cab prewet/etc. discounted 25%, a savings of \$4,800.00.		
9.00		CEJN donated pressure relief coupling system @ N/C, a savings of \$782.00		
		OPTIONAL ITEMS:		
1.00		For Swenson LAI1000 Anti-Icing unit. 1000 gallon capacity, SS leg stand kit, anti-icing pump, lane valves, TG latch bar, ADD \$12,768.00.		

Quote valid for 30 days.

Subtotal	89,470.00
Sales Tax	
TOTAL	89,470.00

Village of Carol Stream
Interoffice Memorandum

MEMO TO: Joe Breinig, Village Manager

FROM: Philip J. Modaff, Director of Public Works 

DATE: March 2, 2016

RE: Motion to Enter Into an Engineering Services Agreement for WRC NPDES Permit Assistance with Baxter & Woodman, Inc.

The new operating permit for the Water Reclamation Center (WRC), issued in October 2015, came with a significant set of new special conditions that the Village is required to meet over the next several years. Due to the Village's ongoing work with the DuPage River Salt Creek Work Group (DRSCW) we have been aware that these new special conditions would likely show up in the operating permit issued by the Illinois Environmental Protection Agency (IEPA) and that there would be expenses associated with compliance.

The list of special conditions and associated tasks is considerable, but the major projects which will require attention starting immediately, and continuing for two to three years, includes:

- Review and update of the sewer use ordinance including the enforcement response plan, the pre-treatment program and an evaluation of local limits;
- Monitoring of copper, zinc and ammonia levels
- Completion of a Capacity, Management, Operations and Maintenance (CMOM) study to assure adequate sanitary sewer capacity at all times;
- A phosphorous optimization plan and feasibility study to determine how, and at what cost, the plant will reduce phosphorous effluent when the IEPA lowers the limit in future permits. (Note: the Village has recently entered into an agreement with CH2M for services related to this project).

I have met with Baxter & Woodman to review the list of remaining projects required over the next several years as well as the schedule needed to complete the tasks within the deadlines established by IEPA. Some of these tasks require an initial progress report as early as April 1, 2016. Funds to support engineering services are provided in the current fiscal year budget as well as in the proposed FY17 budget, and also projected into FY18.

Page Two
March 2, 2016

Baxter & Woodman is uniquely qualified to aid us in meeting the special conditions due to their intimate knowledge of plant history, infrastructure and operations. Baxter & Woodman has also been closely monitoring and contributing to the work of the DRSCW over the past several years in preparation for the new permit special conditions. The work ahead of us on these compliance matters will require coordination between staff and consulting engineering and operations resources. Baxter & Woodman has demonstrated their willingness to successfully work with staff and CH2M on projects in the past that have produced both quality outcomes and cost-savings.

Attached is a proposed Engineering Services Agreement from Baxter & Woodman to conduct a variety of detailed projects over the next three years. Because the final scope of some of the work tasks will be determined in part by results of monitoring, testing and survey results, I directed them to prepare this proposal with an amount not-to-exceed for each major task. The total not-to-exceed amount is \$130,400 over the three-year period that the work will take place. Assuming the full not-top-exceed amount, I expect the expenses will be incurred on the following schedule:

- FY16: \$15,000
- FY17: \$90,900
- FY18: \$24,500

I am recommending a Motion to Enter Into An Engineering Services Agreement with Baxter & Woodman, Inc., for WRC NPDES Permit Assistance in an amount not-to-exceed \$130,400.00 over the next three fiscal years.

Attachment

VILLAGE OF CAROL STREAM, ILLINOIS
WRC NPDES PERMIT ASSISTANCE

ENGINEERING SERVICES AGREEMENT

THIS AGREEMENT is made this _____ day of _____ 2016, by and between the Village of Carol Stream, Illinois, hereinafter referred to as the Village, and Baxter & Woodman, Inc., Consulting Engineers, hereinafter referred to as the Engineers, for engineering services required by the Village for assisting with compliance with Special Conditions in the Water Reclamation Center NPDES permit, hereinafter referred to as the Project.

WITNESSETH that in consideration of the covenants herein, these parties agree as follows:

SECTION 1. The Project consists of assisting with compliance with Special Conditions in the Water Reclamation Center NPDES permit, as more completely described in Exhibit A, attached hereto. After written authorization by the Village, the Engineers shall provide professional services for the Project. These services will include serving as the Village's representative in all phases of the Project, providing consultation and advice, and furnishing customary engineering services, as enumerated in Exhibit B, attached hereto.

SECTION 2. The Village shall compensate the Engineers for the professional services enumerated in Exhibit B hereof as follows:

The Engineers' fee for the professional engineering scope of services as listed in Exhibit B shall be computed on the basis of their hourly billing rates for actual work time performed plus reimbursement of out-of-pocket expenses including travel costs which total amount will not exceed \$130,400, Engineers' Project No.150800.90. Compliance with individual NPDES Special Conditions are as follows:

Special Condition 10 (Pretreatment)	\$60,000
Special Condition 15 (CMOM)	\$20,000
Special Condition 16/22/23 (Copper/Zinc)	\$25,600
Special Condition 19 (Excess Flow)	\$5,000
Special Condition 20/21 (Ammonia)	\$14,800
NPDES Project Management	\$5,000

The Village shall reimburse the Engineers for costs associated with employment of laboratory services as set forth in Paragraph 3.9.

SECTION 3. The parties hereto further mutually agree:

3.1 The Engineers may submit requests for periodic progress payments for

services rendered. Payments shall be due and owing by the Village in accordance with the terms and provisions of the Local Government Prompt Payment Act, Illinois Compiled Statutes, Ch. 50, Sec. 505, et. seq.; and the Engineers may, after giving seven (7) days written notice to the Village, suspend services under this Agreement until the Engineers have been paid in full all amounts due for services, expenses, and late payment charges as provided in such Act.

3.2 This Agreement may be terminated, in whole or in part, by either party if the other party substantially fails to fulfill its obligations under this Agreement through no fault of the terminating party; or the Village may terminate this Agreement, in whole or in part, for its convenience. However, no such termination may be effected unless the terminating party gives the other party (1) not less than ten (10) calendar days written notice by certified mail of intent to terminate, and (2) an opportunity for a meeting with the terminating party before termination. If this Agreement is terminated by either party, the Engineers shall be paid for services performed to the effective date of termination, including reimbursable expenses. In the event of contract termination, the Village shall receive reproducible copies of Drawings, Specifications and other documents completed by the Engineers.

3.3 The Engineers agree to hold harmless and indemnify the Village and each of its officers, agents and employees from any and all liability claims, losses, or damages including reasonable attorney's fees to the extent that such claims, losses, damages or expenses are caused by the Engineers' negligent errors, acts or omissions, but not including liability, claims, losses or damages due to the negligence of the Village or other consultants, contractors or subcontractors working for the Village, or their officers, agents and employees.

In the event claims, losses, damages or expenses are caused by the joint or concurrent negligence of the Engineers and the Village they shall be borne by each party in proportion to its negligence.

The Village acknowledges that the Engineers is a Business Corporation and not a Professional Service Corporation, and further acknowledges that the corporate entity, as the party to this contract, expressly avoids contracting for individual responsibility of its officers, directors, or employees.

The Village and Engineers agree that any claim made by either party arising out of any act of the other party, or any officer, director, or employee of the other party in the execution or performance of the Agreement, shall be made solely against the other party and not individually or jointly against such officer, director, or employees.

3.4 For the duration of the Project, the Engineers shall procure and maintain insurance for protection from claims under worker's compensation acts, claims for damages because of bodily injury including personal injury, sickness or disease or death of any and all employees or of any person other than such employees, and from claims or damages because of injury to or destruction of property including loss of use resulting therefrom, alleged to arise from the Engineers' negligence in the performance of services under this Agreement. The Village shall be named as an additional insured on the Engineers' general liability insurance policy. The policy which names the Village as an additional insured shall also name "its officers and employees" as covered parties, and that policy and the other

policies specified below shall, with regards to certificates of insurance, provide that the coverage shall not be cancelled, modified or reduced without 10 days' prior written notice to the Village. All policies shall be with insurance companies with a rating of A- or above. The limits of liability for the insurance required by this Subsection are as follows:

(1)	Worker's Compensation:	Statutory Limits
(2)	General Liability	
	Per Claim:	\$1,000,000
	Aggregate:	\$2,000,000
(3)	Automobile Liability	
	Combined Single Limit:	\$1,000,000
(4)	Excess Umbrella Liability	
	Per Claim and Aggregate:	\$5,000,000
(5)	Professional Liability	
	Per Claim and Aggregate:	\$5,000,000/\$5,000,000

3.5 Notwithstanding any other provision of this Agreement, and to the fullest extent permitted by law, the total liability, in the aggregate, of the Engineers and their officers, directors, employees, agents, and any of them, to the Village and anyone claiming by, through or under the Village, for any and all claims, losses, costs or damages whatsoever arising out of, resulting from or in any way related to the Project or the Agreement from any cause or causes, including but not limited to the negligence, professional errors or omissions, strict liability or breach of contract or warranty express or implied of Engineers or their officers, directors, employees, agents or any of them, hereafter referred to as the "Village's Claims", shall not exceed the total insurance proceeds available to pay on behalf of or to the Engineers by their insurers in settlement or satisfaction of Village's Claims under the terms and conditions of Engineers' insurance policies applicable thereto, including all covered payments made by those insurers for fees, costs and expenses of investigation, claims adjustment, defense and appeal. The limitation regarding insurance should only be applicable if the Engineers keep in place the insurance policies set forth in Section 3.4.

The Village and Engineers agree to waive against each other all claims for special, incidental, indirect, or consequential damages arising out of, resulting from, or in any way related to the Project.

3.6 The Engineers are responsible for the quality, technical accuracy, timely completion, and coordination of all Designs, Drawings, Specifications, Reports, and other professional services furnished or required under this Agreement. The Engineers shall endeavor to perform such services with the same degree of knowledge, skill and diligence normally employed by professional engineers performing the same or similar services.

3.7 The Village may, at any time, by written order, make changes within the general scope of this Agreement in the services to be performed by the Engineers. If such changes cause an increase or decrease in the Engineers' fee or time required for

performance of any services under this Agreement, whether or not changed by any order, an equitable adjustment shall be made and this Agreement shall be modified in writing accordingly. No service for which an additional compensation will be charged by the Engineers shall be furnished without the written authorization of the Village.

3.8 All Reports, Drawings, Specifications, other documents, and electronic media prepared or furnished by the Engineers pursuant to this Agreement are instruments of service in respect to the Project, and the Engineers shall retain the right of reuse of said documents and electronic media by and at the discretion of the Engineers whether or not the Project is completed. Reproducible copies of the Engineers' documents and electronic media for information and reference in connection with the use and occupancy of the Project by the Village and others shall be delivered to and become the property of the Village upon request; however, the Engineers' documents and electronic media are not intended or represented to be suitable for reuse by the Village or others on additions or extensions of the Project, or on any other project. Any such reuse without verification or adaptation by the Engineers for the specific purpose intended will be at the Village's sole risk and without liability or legal exposure to the Engineers, and the Village shall indemnify and hold harmless the Engineers from all claims, damages, losses and expenses including attorneys' fees arising out of or resulting therefrom. Any furnishing of additional copies and verification or adaptation of the Engineers' documents and electronic media will entitle the Engineers to claim and receive additional compensation from the Village. Electronic media are furnished without guarantee of compatibility with the Village's software or hardware, and the Engineers' sole responsibility for such media is to furnish replacements of defective disks within 30 days after initial delivery.

3.9 The compensation for engineering services set forth in Section 2 hereof shall include supervision of any laboratory services required by the Engineers for the Project. The Engineers shall make all necessary arrangements, subject to the prior approval by the Village, and employ qualified subconsultants for all laboratory services. The cost of such subconsultant services shall be a separate expense to the Village and the Village shall reimburse the Engineers for the actual costs of the laboratory services plus five percent (5%) service charge upon submission of proper invoices.

3.10 The Engineers are an equal opportunity employer and hereby incorporate the requirements of 44 Ill. Adm. Code 750 Appendix A, as applicable.

3.11 Any provision or part thereof of this Agreement held to be void or unenforceable under any law shall be deemed stricken and all remaining provisions shall continue to be valid and binding upon the parties. The parties agree that this Agreement shall be reformed to replace such stricken provision or part thereof with a valid and enforceable provision which comes as close as possible to expressing the intention of the stricken provision.

3.12 To the extent required by law, the Engineers agree to comply with the provisions of the Employment of Illinois Workers on Public Works Act, and to comply with all other provisions of Illinois law, which affect the persons who perform work and the conditions under which their work takes place. In the event that the terms of this

Agreement, or the actions of the Engineers are found to have not complied with the law, then the Engineers shall indemnify and hold the Village harmless, and pay all amounts determined to be due, including, but not limited to fines, costs, attorneys' fees and penalties.

3.13 This Agreement contains and embodies the entire and integrated agreement between parties hereto and supersedes all prior negotiations, representations, or agreements, either written or oral.

IN WITNESS WHEREOF, the parties hereto have caused the execution of this Agreement by their duly authorized officers as of the day and year first above written.

BAXTER & WOODMAN, INC.

VILLAGE OF CAROL STREAM, ILLINOIS

By

Daryl Wald
Vice President

By

Mayor

Date of Signature

Date of Signature

(SEAL)

ATTEST:

ATTEST:

Barbara Tobin
Deputy Secretary

Clerk

Attachment

I:\Mokena\CRSTV\150800-NPDES Compliance\Contract\NPDES ESA.Doc

(Latest update 5-2-11)

VILLAGE OF CAROL STREAM, ILLINOIS
WRC NPDES PERMIT ASSISTANCE

EXHIBIT A

PROJECT DESCRIPTION

The Village of Carol Stream's NPDES permit for the Water Reclamation Center (WRC) was renewed on October 1, 2015. The NPDES permit contained a number of new Special Conditions that the WRC will need to comply with. Each Special Condition has its own compliance and reporting schedule. The scope of this Project is to assist with compliance with the following Special Conditions:

- Special Condition 10: Pretreatment
- Special Condition 15: CMOM
- Special Condition 16/22/23: Copper and Zinc
- Special Condition 19: Excess Flow
- Special Condition 20/21: Ammonia

Special Condition 10 requires the Village to implement and enforce its approved Pretreatment Program. Several updates to the program are required to meet the requirements of the revised NPDES permit including:

- Modifications to the Sewer Use Ordinance to incorporate the revisions of the Pretreatment Streamlining Rule;
- Updates to the Enforcement Response Plan (ERP) to coordinate with the revised ordinance;
- A technical re-evaluation of the Local Limitations consistent with U.S. EPA's Local Limits Development Guidance; and
- Updates to the inventory of Industrial Users (IUs), which is to be completed annually, to ensure that all Significant Industrial Users are properly identified, characterized, and categorized.

Special Condition 10 requires the Village to collect data from WRC, residential and stream sampling sites to support the local limits evaluation. The goal is to develop defensible local limits that allow the industrial users the most flexibility while meeting the USEPA requirements.

Special Condition 15 requires the Village to develop and implement a Capacity, Management, Operations and Maintenance (CMOM) plan for its sanitary sewer system. The CMOM plan will assist with the goal of eliminating sanitary sewer overflows and basement backups.

Special Condition 16/22/23 allows the Village to collect data to support a site specific metal translator for copper and zinc. The goal is to remove copper and zinc limits from the permit or raise them to a level that the WRC will comply.

Special Condition 19 allows the Village to collect data in the receiving stream and outfall during wet weather events to support the ability for the WRC to continue to utilize Outfall 001 when the plant

capacity is exceeded.

Special Condition 20 allows the Village to collect pH and temperature data in support of a site specific ammonia limit. The goal is to increase ammonia limits to concentrations from the previous permit.

VILLAGE OF CAROL STREAM, ILLINOIS
WRC NPDES PERMIT ASSISTANCE

EXHIBIT B

SCOPE OF SERVICES

Project Management

PROJECT MANAGEMENT

- Plan, schedule, and control activities to complete the Project. These activities include, but are not limited to, budget, schedule, and scope. Submit a monthly status report via email describing tasks completed the previous month and outlining goals for the subsequent month.
- Coordinate with the Village and CH2M to ensure that progress reports and milestones required by the NPDES permit are met.

MEETINGS

- Hold a kick-off meeting with staff and the project team to establish clear lines of communication, introduce staff to the team members, and establish the Village's detailed needs, objectives, and goals for the Project. The meeting will also be used to obtain information, plans, atlases, and other data to be supplied by the Owner, and to set schedules and guidelines for any future design meetings.
- Hold progress meetings on a quarterly basis, including at milestone reporting dates, to update the Village, CH2M and the Project team on the current status of the NPDES Special Conditions.

The scope of services for each special condition are as follows:

Special Condition 10 – Sewer Use Ordinance Modifications to incorporate Streamlining Rule -
Use the USEPA's most recent model Pretreatment Ordinance that contains required streamlining changes as the basis for the Village's Pretreatment Ordinance. Modify the model based on recent comments and conversations with both the EPA and the USEPA. Coordinate modifications with existing ordinance legacy sections and building department criteria. The submittal to USEPA is required prior to October 1, 2017.

1. Meet with Village/CH2M to discuss pretreatment objectives and needs,
2. Provide a presentation that is an overview of the draft Sewer Use/Pretreatment (SU/PT) ordinance, its strengths, and decisions that need to be made by the Village/CH2M,
3. Submit SU/PT to the Village/CH2M for review and comment and subsequently modify. Modifications are limited to four hours for staff modifications and four hours for attorney modifications. Modification time beyond that will be billed at standard rates once approval is received from the Village,

4. Submit SU/PT ordinance rewrite to USEPA with 12 page legal cross-reference. Changes that USEPA would want that were not included in the model ordinance that have been identified in other program ordinance modifications will be included in the draft to prevent additional comment from USEPA,
5. Discuss comments with USEPA and make modifications.
6. Submit adoption documentation to USEPA.

Special Condition 10 – Enforcement Response Plan (ERP) Updates to incorporate Streamlining Rule

The Enforcement Response Plan will contain detailed procedures describing how the Village/CH2M investigates and responds to instances of non-compliance for industrial users. Update and modify the current plan to coordinate with the revised sewer use/pretreatment ordinance (SU/PT ordinance). The draft submittal to USEPA is required prior to October 1, 2017.

1. Discuss informal regulatory options with Village/CH2M that are not in the SU/PT ordinance so they are clearly contained in the ERP,
2. Produce a draft ERP with new streamlining or other options from the revised SU/PT ordinance,
 - o Provide monitoring criteria,
 - o Provide 10 samples of common Notice of Violation (NOV)/Reporting NOV formats identified in the ERP,
3. Incorporate the Village/CH2M's comments into the final ERP document,
4. Check the provision cross references to the codified ordinance,
5. Submit to USEPA for review and comment,
6. Revise as needed to incorporate comments from USEPA, and

Special Condition 10 – Technical Re-Evaluation of Local Limits

Assist the Village in updating the local limits as required by the Village's NPDES permit Special Condition 10 and make them legally defensible. USEPA requires that the evaluation be consistent with its Local Limits Development Guidance (July 2004). Local limit are required to be submitted to USEPA prior to October 1, 2017.

1. Conduct a kick-off meeting with Village/CH2M to define sampling and data needs of Project.
2. Obtain and screen influent, effluent, and sludge data from the 2014 and 2015 Annual Pretreatment Report and first half 2016 semi-annual sampling (if completed), for routine local limits evaluation and identify if any other non-organic or organic pollutants need to be evaluated.
3. Discuss additional data the Village/CH2M needs to schedule to complete local limits evaluation. The specific samples needed for the re-evaluation are as follows:
 - o Publicly-Owned Treatment Works (POTW): Twelve (12) days of paired analyses of time weighted raw influent and effluent to determine removal efficiencies for the plant,

- o Bio-solids: 503 and pretreatment annual report data from the 2014 and 2015 years can be used as the bulk of the bio-solids information. One sample will be collected during the POTW sampling cycle,
- o Waterway Segment Sampling: Twelve (12) samples grab samples taken on the day of the raw influent samples will be required upstream of the POTW outfall to define the stream characteristics, and
- o Residential/domestic sources: A total of nine (9) samples should be taken from three (3) residential/domestic source locations that include housing more than five (5) years old, housing less than five (5) years old, a location that includes housing and commercial unregulated users that discharge only domestic waste.

The analyses that are identified by USEPA that will need to be evaluated for the development of local limits include the following metals and non-metals:

Ammonia N	Chloride*	Nickel
Arsenic	Copper	Phosphorus*
BOD	Cyanide	Selenium
COD	Fats, Oil & Grease*	Silver
Cadmium	Lead	Sulfate*
Chromium (hexavalent)	Mercury	TSS
Chromium (Total)	Molybdenum	Zinc

*Pollutants that we recommend be evaluated based on emerging USEPA trends, Illinois Water Quality Standards or Village NPDES requirements.

The cost of sampling and analyses, which is estimated to be between \$15,000-\$20,000, is not included in this proposal.

4. Provide the Village/CH2M with the required sampling and analytical requirements, criteria for cancelling samples, and define that the laboratory used provides the project data in a spreadsheet format. Review and comment on the Village/CH2M's sampling schedule once completed. The Village/CH2M will review the data for use of the correct method, holding times, preservatives, and quality control.
5. Prepare spreadsheets to evaluate and summarize the Village/CH2M's analytical data. Screen non-detect data for appropriate replacement. Evaluate data statistically to identify outliers.
6. Calculate hardness based Illinois General Use Water Quality Standards for the local limit evaluation.
7. Input Village data plus state and federal criteria in USEPA approved local limit tables and prepare preliminary local limit calculations based on most stringent calculation of the nine criteria. Address calculation aberration such as negative values. Verify the calculated local limits are practical.
8. Meet with Village/CH2M to present proposed preliminary local limits and supporting data. Discuss whether additional data is needed in order to improve targeted local limits calculations. Provide Village/CH2M with additional sampling requirements, if required.
9. Update local limits if additional sampling data was required and provide Village/CH2M with revised local limits.

10. Provide draft report for Village/CH2M review that includes executive narrative summary and appendices. Appendices will include USEPA Region V spreadsheet, POTW information including permit requirements, identify sources of state and federal defaults used in the calculations as well as summarize Village data and requirements. Incorporate Village/CH2M's comments and finalize local limits report.
11. Submit final local limits report to Village and USEPA. Address any comments received from USEPA.

The Village/CH2M will coordinate the sampling and analyses for the required data with an outside laboratory, provide a final sampling schedule with appropriate criteria for review and provide data summarized in a format defined by Baxter & Woodman. The Village/CH2M will also prepare and provide Baxter & Woodman with the following:

1. Influent, effluent, and sludge data from the 2014 and 2015 Annual Pretreatment Reports in an Excel spreadsheet for each WWTP. 2016 data will be added once it is available.
2. Summarize and provide influent flow data (average daily flow by month) in an Excel Spreadsheet for 2014, 2015, and 2016 (added when available).
3. Sludge information for each WWTP:
 - o Flow Data in Excel Spreadsheet (flow to digester, thickened WAS flow to digester, sludge flow to disposal & percent solids),
 - o Quarterly & Semi-Annual Sludge Sampling Data,
 - o Semi-Annual Quantity Sludge Management Report Form, and
 - o Sludge Land Application Reports
4. Summarize and provide the 2014 & 2015 analytical results and flow for all permitted industrial users.
5. Summarize collection system problems.
6. Summarize pollutants that have caused violations or operational problems at the POTW, including conventional pollutants; fire and explosions; corrosion; flow obstructions; increased temperature in the sewer system; toxic gases, vapors or fumes that caused acute worker health and safety problems; toxicity found through Whole Effluent Toxicity testing; or inhibition to processes.

Special Condition 10 - Industrial User Survey Database Hosting and
Special Condition 17 - Phosphorous Source Reduction Database Hosting

Assist the Village in updating the list of Significant Industrial Users to meet the requirements of Special Condition 10 of the NPDES Permit. In addition, assist the Village in locating sources of Phosphorous through a Food Service Establishment (FSE) Survey.

SURVEY

1. The Village/CH2M will identify all possible businesses and Food Service Establishments through a windshield survey, using resources from the Village and/or by obtaining a copy of the current Illinois Manufacturing Directory and Services Directory lists provided by Baxter & Woodman to create the survey recipient lists.

Two Excel spreadsheets will need to be provided to Baxter & Woodman, one list of industry names and addresses for the industrial survey and a second list containing Food Service Establishment names and addresses. These lists will be used by Baxter & Woodman to load information into the online GIS database system.

2. Prepare surveys that will include a web address and login for survey respondents to complete the survey online. Provide technical support to the Village during the survey collection process. Baxter & Woodman, Inc. will prepare:
 - o Two surveys: one for each type of user (Industrial and FSE).
 - o Instructions for completing the survey.
3. The Village/CH2M will prepare standard cover letters to accompany the surveys, print individual letters, stuff envelopes, apply postage, and mail all letters. The Village will collect phone numbers and contact names for industries that are to receive a survey.
4. Baxter & Woodman will provide the online survey, software, on-going annual hosting (12 month access), server connection, and technology support so that businesses can load operation details directly into the database.
Our fee does not include ARCGIS licensing fees, which we understand the Village already has.
5. The Village/CH2M will manually enter into the database the information contained in any hardcopies of surveys that are received by mail.

SURVEY FOLLOW-UP

6. Baxter & Woodman will provide 2 hours of training to instruct the Village/CH2M on how to obtain information from the database system for follow up and how to utilize the system for tracking of each step.
7. The Village/CH2M will complete all survey follow up (Industrial and FSE) to collect surveys by placing phone calls and visiting users.
8. The Village/CH2M will screen all industrial surveys in the database to determine which firms are of concern or have not provided sufficient information to determine an evaluation and will place follow-up phone calls to industries to obtain more information about their businesses.
9. The Village/CH2M will use the online survey database to track the status during the process and provide phone log details in the database system. These are valuable tools for IEPA/USEPA and should be included as part of the report to fulfill the requirements of the Pretreatment Program.

SITE INSPECTIONS AND CLASSIFICATIONS

10. The Village/CH2M will complete site inspections of industries, and review information to properly classify and identify significant or categorical industrial users or potential phosphorus dischargers. If the Village wishes for Baxter & Woodman staff to review surveys, assist in the classification or permitting of industries these services can be included and would be billed at standard rates once approval is received from the Village.

11. The Village/CH2M will provide a summary for each industrial user site inspection completed. This summary should also include justification why industries are or are not classified as a CIU or SIU for documentation in Special Condition 17.
12. Baxter & Woodman will provide the Village/CH2M with all data from the surveys in a Geodatabase in XML format for use by the Village in their GIS system. The initial setup of this system for the industrial user and food service establishment surveys will allow the database system to be used for future surveys at a lower cost.
13. Baxter & Woodman will provide summaries of the data from the Survey Database system in electronic format to be included with the Village/CH2M documents for submittal to IEPA.
14. The Village/CH2M will create a report and letter response to IEPA including information from the Geodatabase file to meet the requirements of Special Condition 10.

SPECIAL CONDITION 15: CAPACITY, MANAGEMENT, OPERATION, AND MAINTENANCE (CMOM) PLAN

Assure adequate sanitary sewer Capacity at all times through proper Management, Operation, and Maintenance.

1. PROJECT WORKSHOP MEETING

- A Project Workshop meeting with Village staff and the Project team will be held for the CMOM Plan. The purposes of the meeting are to establish clear lines of communication, introduce the Village staff to the team members, and establish the Village's detailed needs, objectives, and goals for the Project. The meeting will also be utilized to obtain information, plans, atlases, and other data to be supplied by the Village, and set schedules and guidelines for future design meetings.

2. GATHER AND REVIEW DATA

- **Request to Village:** We ask the Village to gather the following documents, if available:
 - Sewer GIS shapefiles
 - Sanitary Sewer Atlas Map(s):
 - Large Overall
 - Reduced, Atlas book
 - Sewer System Description
 - Organization Chart
 - Sewer Use and Pretreatment Ordinances
 - Sewer Operating Budget
 - Sewer Capital Improvement Plan (CIP)
 - Sewer Master Plans or Evaluations
 - Sewer Design Standards
 - Emergency Response Plans (sanitary related: sewer backup, overflow, etc)
 - Sewer equipment O&M schedule or documentation
 - List (or map) of Overflows and Basement Backups
 - Record Drawings (pump stations)

- O&M Manuals (pump stations)

- Attend two (2) meetings with the City staff to review the requirements. Assist the City in collecting and organizing the existing information into a file binder for record keeping. An electronic version of the file binder will also be made.

3. MEETINGS WITH VILLAGE STAFF

- Conduct meetings with staff at times during the Project to clarify staff wishes and available information.
- Because of the complexity of this Program, two (2) additional meetings have been scheduled with the staff.
- *The total contract includes five (5) meetings and one (1) presentation.*

4. PREPARE CMOM PLAN

- The plan shall include the following information, as outlined in Special Condition 15 of the NPDES Permit:

A. Measures and Activities:

1. A complete map and system inventory for the collection system owned and operated by the Permittee;
2. Organizational structure; budgeting; training of personnel; legal authorities; schedules for maintenance, sewer system cleaning, and preventative rehabilitation; checklists, and mechanisms to ensure that preventative maintenance is performed on equipment owned and operated by the Permittee;
3. Documentation of unplanned maintenance;
4. An assessment of the capacity of the collection and treatment system owned and operated by the Permittee at critical junctions and immediately upstream of locations where overflows and backups occur or are likely to occur; use flow monitoring as necessary;
5. Identification and prioritization of structural deficiencies in the system owned and operated by the Permittee;
6. Operational control, including documented system control procedures, scheduled inspections and testing;
7. The Permittee shall develop and implement an Asset Management strategy to ensure the long-term sustainability of the collection system. Asset Management shall be used to assist the Permittee in making decisions on when it is most appropriate to repair, replace or rehabilitate particular assets and develop long-term funding strategies; and
8. Asset Management shall include but is not limited to the following elements:
 - a. Asset Inventory and State of the Asset;

- b. Level of Service;
- c. Critical Asset Identification;
- d. Life Cycle Cost; and
- e. Long-Term Funding Strategy.

B. Design and Performance Provisions:

1. Monitor the effectiveness of CMOM;
2. Upgrade the elements of the CMOM plan as necessary; and
3. Maintain summary of CMOM activities.

C. Overflow Response Plan:

1. Know where overflows within the facilities owned and operated by the Permittee occur;
2. Respond to each overflow to determine additional actions such as clean up; and
3. Locations where basement back-ups and/or sanitary sewer overflows occur shall be evaluated as soon as practicable for excessive inflow /infiltration, obstructions or other causes of overflows or back-ups as set forth in the System Evaluation Plan.

D. System Evaluation Plan:

1. Summary of existing SSO and Excessive I/I areas in the system and sources of contribution;
2. Evaluate plans to reduce I/I and eliminate SSOs;
3. Special provisions for Pump Stations and force mains and other unique system components; and
4. Construction plans and schedules for correction.

E. Reporting and Monitoring Requirements:

1. Program for SSO detection and reporting; and
2. Program for tracking and reporting basement back-ups, including general public complaints.

F. Third Party Notice Plan:

1. Describes how, under various overflow scenarios, the public, as well as other entities, would be notified of overflows within the Permittee's system that may endanger public health, safety or welfare;
2. Identifies overflows within the Permittee's system that would be reported, giving consideration to various types of events including events with potential widespread impacts;
3. Identifies who shall receive the notification;

4. Identifies the specific information that would be reported including actions that will be taken to respond to the overflow;
5. Includes a description of the lines of communication; and
6. Includes the identities and contact information of the responsible POTW officials and local, county, and/or state level officials.

5. DELIVERABLES: DRAFT AND FINAL CMOM PLAN

- Submit electronic draft report summarizing the Village's CMOM Program.
- Reply to comments from Village Staff.
- Prepare Final CMOM Plan and submit electronically to Village.
- Present Final CMOM Plan to Board.

Special Condition 16/22/23:

Copper Translator / Interim Report Assistance

A metals translator plan, utilizing site-specific hardness and metals translator information, will be utilized for revising the copper limit. Specifically, the scope proposed for copper compliance issues is as follows:

- Submit a copper translator study plan to the IEPA. The plan will describe the sampling activities and sampling location. The Village will collect the samples and arrange for the laboratory analyses. The study will require a minimum of 12 samples of total and dissolved copper from both the effluent and receiving stream.
- Provide interim progress reports as required.
- Monitor the sampling results and coordinate with the laboratory in case of suspect results. Any needed coordination with the laboratory and/or the IEPA is assumed to be via phone or email. No meetings with the IEPA in Springfield are included.
- Submit a letter report to the IEPA containing the full results of the study and requesting that the IEPA modify the NPDES permit accordingly in conjunction with the hardness study. The goal of the study would be to prevent a copper limit from appearing in the draft permit.

Zinc Translator / Interim Report Assistance

A metals translator plan, utilizing site-specific hardness and metals translator information, will be utilized for revising the zinc limit. Specifically, the scope proposed for zinc compliance issues is as follows:

- Submit a zinc translator study plan to the IEPA. The plan will describe the sampling activities and sampling location. The Village will collect the samples and arrange for the laboratory analyses. The study will require a minimum of 12 samples of total and dissolved zinc from both the effluent and receiving stream.

- Provide interim progress reports as required.
- Monitor the sampling results and coordinate with the laboratory in case of suspect results. Any needed coordination with the laboratory and/or the IEPA is assumed to be via phone or email. No meetings with the IEPA in Springfield are included.
- Submit a letter report to the IEPA containing the full results of the study and requesting that the IEPA modify the NPDES permit accordingly in conjunction with the hardness study. The goal of the study would be to prevent a zinc limit from appearing in the draft permit.

Hardness Study

A Hardness Study will allow the Village to use site specific hardness from the receiving stream to assist in supporting the case of the above translator studies. The implementation of a site specific hardness evaluation will take 12-24 months. This time frame depends on the suggested schedule from IEPA and their approval for the sampling. At several points during the sampling period we will evaluate the results, should the results indicate that there is no benefit from the results, we will recommend that the Village abandon this Evaluation.

- Prepare a letter to the IEPA requesting that the Village be allowed to perform a Receiving Stream Hardness Evaluation. The letter will describe the sampling activities and sampling locations.
- The Village/CH2M will collect the samples and arrange for the laboratory analyses.
- Monitor the sampling and analytical results on a weekly basis and then prepare a letter report to the IEPA detailing the results of the study.
- Following establishment of the Stream Hardness Value by the IEPA Standards Unit, we will request that the IEPA Permit section modify the NPDES permit issued to the Village.

The cost of sampling and analyses, for the copper translator, zinc translator and hardness study is not included in this proposal.

Special Condition 19: Excess Flow

Baxter and Woodman prepared an excess flow monitoring plan dated November 20, 2015 to describe data collection during certain wet weather events. The data collection consists of measuring the stream flow, and sampling/testing the receiving stream water quality upstream and downstream of the WRC outfall. The plan was approved by IEPA on November 30, 2015. The scope includes:

- Prepare a gauging table of stream depth vs discharge for the receiving stream to allow plant staff to record flows during wet weather events.
- Analyze data collected by plant staff for the receiving stream water quality and compare the WRC effluent. Advise the Village of the findings.
- Submit data in a tabular format to IEPA.

Special Condition 20/21: Ammonia-Nitrogen Compliance Assistance Translator / Interim Report Assistance

A site-specific monitoring study will be prepared to demonstrate that the existing limits adequately protect the receiving stream and that new, lower limits for ammonia-nitrogen are not necessary. The study includes obtaining 12-months of data and recalculating the site-specific ammonia-nitrogen limit after the stream monitoring data has been collected.

- Submit an ammonia-nitrogen monitoring plan to the IEPA. The plan will describe the sampling activities and sampling location. The Village will collect and analyze the samples. The study will require twice a week samples of pH and temperature of the receiving stream.
- Monitor the sampling results and coordinate with the Village in case of suspect results. Any needed coordination with the IEPA is assumed to be via phone or email. No meetings with the IEPA in Springfield are included.
- Provide interim progress reports as required.
- Submit to the IEPA a letter report containing the summary and discussion of the pH and temperature monitoring.
- Submit to the IEPA the full results of the monitoring effort with the updated estimate of the site-specific ammonia-nitrogen limits. The submittal will request that the IEPA recalculate the ammonia-nitrogen limits and modify the NPDES permit accordingly.

**AN ORDINANCE APPROVING A SPECIAL USE PERMIT FOR
A DRIVE-UP SERVICE WINDOW AND AN AMENDMENT TO AN APPROVED
SPECIAL USE PERMIT FOR A PLANNED UNIT DEVELOPMENT
(HITESH PATEL, DUNKIN' DONUTS, 222 W. ARMY TRAIL RD.)**

WHEREAS, Hitesh Patel, on behalf of Dunkin' Donuts, hereinafter referred to as the Petitioner, has petitioned the Village of Carol Stream for a Special Use Permit for a Drive-Up Service Window and an Amendment to an Approved Special Use Permit for a Planned Unit Development, as provided in Sections 16-9-2(C)(1) and 16-9-4(C)(1) of the Carol Stream Code of Ordinances, on the property legally described in Section 2 herein and commonly known as 222 W. Army Trail Road, Carol Stream, Illinois; and

WHEREAS, pursuant to Section 16-15-8 of the Carol Stream Code of Ordinances, the Combined Plan Commission/Zoning Board of Appeals held a public hearing on the above petition on February 22, 2016, following proper legal notice of said public hearing, after which the Commission recommended to the Mayor and Board of Trustees of the Village that the Special Use Permit for a Drive-Up Service Window be approved; and

WHEREAS, the Combined Plan Commission/Zoning Board of Appeals further recommended to the Mayor and Board of Trustees of the Village that the Amendment to an Approved Special Use Permit for a Planned Unit Development be approved; and

WHEREAS, the Combined Plan Commission/Zoning Board of Appeals has filed its Findings and Recommendations regarding the Special Use Permit for a Drive-Up Service Window and the Amendment to an Approved Special Use Permit for a Planned Unit Development with the Mayor and Board of Trustees, and the Mayor and Board of Trustees have duly considered said Findings and Recommendations; and

WHEREAS, the Mayor and Board of Trustees find it to be in the best interest of the Village to grant approval of the Special Use Permit for a Drive-Up Service Window and Amendment to an Approved Special Use Permit for a Planned Unit Development, as set forth in this Ordinance.

NOW, THEREFORE, BE IT ORDAINED BY THE MAYOR AND BOARD OF TRUSTEES OF THE VILLAGE OF CAROL STREAM, DU PAGE COUNTY, ILLINOIS, IN THE EXERCISE OF ITS HOME RULE POWERS, AS FOLLOWS:

SECTION 1:

The Mayor and Board of Trustees of the Village of Carol Stream, after examining the Petition for a Special Use Permit for a Drive-Up Service Window and an Amendment to an Approved Special Use Permit for a Planned Unit Development, and the Findings and Recommendations of the Combined Plan Commission / Zoning Board of Appeals, have determined and find that the requested Special Use Permit and Amendment to an Approved Special Use Permit:

1. Is deemed necessary for the public convenience at the location. *Drive-up service windows are popular at food service establishments, and have been found to be appropriate for the public convenience at many existing Carol Stream restaurants.*
2. Will not be unreasonably detrimental to or endanger the public health, safety, morals, comfort or general welfare. *The drive-up service window represents an improvement to the property aimed at improving the efficiency of operations, which should not be detrimental to or endanger public health, safety, morals, comfort or general welfare.*
3. Will not be injurious to the use and enjoyment of other properties in the immediate vicinity for the purposes already permitted, nor substantially diminish and impair property values within the neighborhood. *The improvements to the property represent a re-investment in the property and should not be injurious to the use and enjoyment of other properties in the immediate vicinity, nor substantially diminish or impair property values within the neighborhood.*
4. Will not impede the normal and orderly development and improvement of surrounding properties for uses permitted in the district. *The drive-up service window should be of no impact on the normal and orderly development and improvement of surrounding properties.*
5. Will provide adequate utilities, access roads, drainage and other important and necessary community facilities. *Adequate utilities, access roads, drainage and other public improvements are already in place.*
6. Will conform to the applicable regulations of the district in which it is located, except as the Village Board may in each instance modify such regulations. *The drive-up service window is expected to operate and conform to all applicable regulations and any conditions of approval as determined by the Combined Plan Commission/Zoning Board of Appeals and Village Board.*

SECTION 2:

The Special Use Permit for a Drive-Up Service Window and Amendment to an Approved Special Use Permit for a Planned Unit Development are hereby approved and granted, subject to the conditions set forth in Section 3, upon the real estate commonly known as 222 W. Army Trail Road, Carol Stream, Illinois, and legally described as follows:

LOT 1 AS DESIGNATED UPON THE PLAT OF BURKE VENTURE SUBDIVISION, BEING A SUBDIVISION OF PART OF THE SOUTHWEST QUARTER OF THE NORTHWEST QUARTER OF SECTION 20 AND PART OF THE SOUTHEAST QUARTER OF THE NORTHEAST QUARTER OF SECTION 19, ALL IN TOWNSHIP 40 NORTH, RANGE 10 EAST OF THE THIRD PRINCIPAL MERIDIAN, IN DUPAGE COUNTY, ILLINOIS

hereinafter referred to as the Subject Property.

SECTION 3:

The approval of the Special Use Permit for a Drive-Up Service Window and Amendment to an Approved Special Use Permit for a Planned Unit Development granted in Section 2 herein is subject to the following conditions:

1. That the inoperable light pole in the southeast corner of the property and the existing wall mounted light fixture at the southeast corner of the building must be repaired and maintained in working order by the property owner by June 1, 2016;
2. That the pavement deficiencies in the northwest quadrant of the plaza parking lot shall be repaired by the property owner by June 1, 2016, and that a building permit must be obtained prior to said parking lot work;
3. That the yellow striping for the drive-through lane be installed for the entire length of the lane for better delineation between the drive-through lane and the bypass lane;
4. That all trash, refuse and recycling containers must be kept within the trash enclosure at the southwest corner of the property, and that the gates to the enclosure must be kept closed at all times except when employees are accessing the enclosure or when the waste hauler is servicing the property;
5. That the applicant must obtain sign permits for all signs, with such permits being separate from the main building permit, and that all new signage must comply with Village Sign Code regulations;
6. That stormwater certification shall be required prior to the issuance of a building permit; and
7. That the site must be maintained and the business must be operated in accordance with all State, County and Village codes and regulations.

SECTION 4:

The Special Use Permit for a Drive-Up Service Window and Amendment to an Approved Special Use Permit for a Planned Unit Development are hereby approved and granted as set forth in the following plans and exhibits:

1. Site Plan and Zoning Analysis (Exhibit A dated 2/12/16), prepared by Studio Silver Architecture + Design, 150 N. Michigan Avenue, Chicago, Illinois 60601.
2. Final PUD Plan-Revised (Exhibit B dated 2/12/16), prepared by Studio Silver Architecture + Design, 150 N. Michigan Avenue, Chicago, Illinois 60601.

3. Architectural Layout and Elevations (Exhibit C dated 2/12/16), prepared by Studio Silver Architecture + Design, 150 N. Michigan Avenue, Chicago, Illinois 60601.
4. Concept Site Plan (Exhibit D dated 2/12/16), prepared by Studio Silver Architecture + Design, 150 N. Michigan Avenue, Chicago, Illinois 60601.
5. Sign Package (Exhibit E dated 7/22/15, 4/15/15, and 8/5/15), prepared by Hilton Displays, 106 W. Summit Hill Drive, Knoxville, TN, 37902.

SECTION 5:

This Ordinance shall be in full force and effect from and after passage, approval and publication in pamphlet form, provided, however, that this Ordinance is executed by the owners or such other party in interest, consenting to and agreeing to be bound by all of the terms and conditions contained within this Ordinance. Such execution and delivery to the Village shall take place within sixty (60) days after the passage and approval of this Ordinance or within such extension of time as may be granted in the discretion of the corporate authorities, by motion.

SECTION 6:

The failure of the owner or other party in interest, or a subsequent owner or other party in interest, to strictly comply with the terms and conditions of this Ordinance, after execution of this Ordinance, shall subject the owner or party in interest to the penalties set forth in Section 16-17-7 A and B of the Carol Stream Code of Ordinances, and/or termination of the special use permit after notice and public hearing in accordance with the procedures required by the Carol Stream Code of Ordinances.

PASSED AND APPROVED THIS 7th DAY OF MARCH, 2016.

AYES:

NAYS:

ABSENT:

ATTEST:

Frank Saverino, Sr. Mayor

Laura Czarnecki, Village Clerk

I, Hitesh Patel, being the owner and/or party in interest of the Subject Property legally described in this ordinance, do hereby accept, concur, and agree to develop and use the Subject Property in accordance with the terms and conditions of this Ordinance, and I understand that if I do not do so, I am subject to the penalties set forth in Section 16-17-7 A and B of the Carol Stream Code of Ordinances, and/or termination of the special use permit. Dunkin Donuts further agrees to indemnify, hold harmless and defend the Village, and its officers, agents and employees from any and all claims, lawsuits, liabilities damages and costs incurred as a result of the approvals as granted herein.

Date

Owner/Party In Interest

GENERAL NOTES:

- 1. ALL CONSTRUCTION MUST COMPLY WITH ALL APPLICABLE CODES.
2. ADA SIGNS WILL COMPLY TO THE ACCESSIBILITY CODE AS ESTABLISHED BY THE STATE LOCAL CODES.
3. ALL CONTRACTOR AND SUBCONTRACTORS WILL INDICATELY MAINTAIN THROUGHOUT WITH THESE CONSTRUCTION OCCUPANCIES AND WILL VERIFY EXISTING SITE AND BUILDING CONDITIONS PRIOR TO SUBMITTING BID.
4. SUBCONTRACTORS, BEFORE BEGINNING THEIR WORK, SHALL CHECK AND VERIFY THEIR PARTICULAR RELATED REQUIREMENTS FOR COMPLIANCE WITH THESE MEASUREMENTS, SURVEY LEVELS, AND SURFACE CONDITIONS AND REPORT THEREON. IT WILL BE CONSIDERED THAT EACH BIDDER UNDERSTANDS AND MEANS EXACTLY WHAT WILL BE REQUIRED.
5. THE ARCHITECT AND HER PROFESSIONAL CONSULTANTS WILL NOT HAVE CONTROL OF AND WILL NOT BE RESPONSIBLE FOR CONSTRUCTION METHODS, MEASUREMENTS, SURVEY, OR FOR SAFETY PRECAUTIONS IN CONNECTION WITH THE WORK ON THIS PROJECT OR FOR THE ACTS OR OMISSIONS OF THE CONTRACTOR, SUBCONTRACTORS, OR ANY OTHER PERSONS PERFORMING ANY OF THE WORK OF THIS JOB.
6. ALL CONTRACTORS WILL PROVIDE ADEQUATE FENCING AND TO ENSURE TO INSURE EDUCATIONAL STABILITY OF THE BUILDING AND ALL RELATED BUILDING COMPONENTS, I.E. SOLARSHIELD, WALLS, INSULATION SHALL REMAIN IN PLACE THROUGHOUT THE CONSTRUCTION PHASE OF THIS PROJECT.
7. ALL WORK WILL BE COORDINATED WITH OTHER TRADES IN ORDER TO AVOID INTERFERENCE AND PRESERVE MECHANICAL AND HVAC CONDITIONS. EACH CONTRACTOR WILL INCLUDE ALL NECESSARY MEASUREMENTS REQUIRED BY CODE AND REQUIRED TO COMPLETE THIS WORK.
8. ALL MATERIALS USED WILL BE NEW AND MEET ALL LABELS WHERE REQUIRED AND MEET APPROPRIATE N.E.A.S.A. STANDARDS.
9. LANDFILL PARTITIONS BEFORE BEGINS CONSTRUCTION TO PREVENT PILING OF DEBRIS. ALL DEBRIS PARTITIONS WILL BE INSTALLED AS NOTED ON THE DRAWINGS. DO NOT SCALE DRAWINGS.
10. VERIFY ALL DIMENSIONS OF THE FIELD PRIOR TO BEGINNING CONSTRUCTION.
11. FOR ALL AREA AND SPREADER DRAWINGS TO BE SUBMITTED UNDER SEPARATE SUBMITTAL.

- 11. ALL SUBCONTRACTORS WILL PROVIDE A CERTIFICATE OF INSURANCE TO THE OWNER AND LANDLORD PRIOR TO STARTING ANY WORK ON THIS PROJECT. CERTIFICATE OF INSURANCE CANNOT BE TERMINATED OR CANCELLED WITHOUT 16 DAYS NOTICE TO THE OWNER.
12. NO SUBSTITUTIONS OF ANY KIND FOR MATERIALS SPECIFIED ON THESE CONSTRUCTION DOCUMENTS IS ALLOWED. NO "EQUIVALENT" SUBSTITUTIONS WILL BE MADE, UNLESS APPROVED IN WRITING BY THE ARCHITECT AND APPROVED BY THE OWNER DUE TO THE LACK OF AVAILABILITY OF ORIGINAL.
13. EACH CONTRACTOR IS RESPONSIBLE FOR FIRST CLASS WORKMANSHIP AND WILL ASSUME ALL RESPONSIBILITY FOR THE CARE AND PROTECTION OF ALL OWN WORK AND MATERIALS FROM DAMAGE. HE WILL MAKE GOOD ANY DAMAGE TO THE SOIL OR OTHER NEARBY CAUSED BY HIMSELF OR WORKMAN EMPLOYED BY HIM.
14. EACH CONTRACTOR WILL BE RESPONSIBLE FOR OSHA VIOLATIONS AND RELATED OSHA FINES/FEES FOR THE SAFETY OF THEIR EMPLOYEES ON SITE. THIS CONTRACTOR AND HER PROFESSIONAL CONSULTANTS WILL BE HELD LIABLE FOR ANY OSHA VIOLATIONS OR FINES/FEES INCURRED BY THE OWNER, OR ANOTHER AGENCY, ON THIS PROJECT FOR ACCIDENTS OR INJURIES CAUSED OR OCCURRED ON THIS PROJECT DURING THE CONSTRUCTION PHASES OF THIS PROJECT.
15. UNDER ALL SUBCONTRACTORS AND SERVICE CONTRACTORS WILL BE REQUIRED TO LANDLORD A COMPLETE RELEASE OF ALL CLAIMS ARISING OUT OF THE CONTRACT. WORKER RECEIPTS IN FULL LEFT THROUGHOUT THEIR FINANCIAL STATEMENT FOR WORK IN PLACE FOR THE OWNER.
16. GENERAL CONTRACTOR TO PAY FOR ALL SCHEDULED SERVICES, AND WILL BE RESPONSIBLE FOR REMOVAL OF DEBRIS ACCUMULATED BY EACH TRADE. HOWEVER, EXACT TIME WILL KEEP THE JOB SITE CLEAN AND SAFE AT ALL TIMES, ALONG WITH A SCHEDULE FINISH AT THE END OF EACH WORKING DAY.
17. CONSTRUCTION CLEAN UP: AFTER ALL OTHER WORK IS COMPLETED AND JUST PRIOR TO TURNING THE SPACE OVER TO THE OWNER, THE CONSTRUCTION MANAGER WILL EMPLOY THE SERVICES OF A PROFESSIONAL CLEANING SERVICE TO CLEAN AND PROTECT ALL INSTALLED EQUIPMENT, SERVICE AREAS, ALONG WITH THE CLEANING OF ALL GLASS WINDOW/DOORWAYS FROM TO OCCUPANCY.
18. FOR ALL AREA AND SPREADER DRAWINGS TO BE SUBMITTED UNDER SEPARATE SUBMITTAL.

PROPOSED DRIVE THRU DUNKIN DONUT HITEESH PATEL

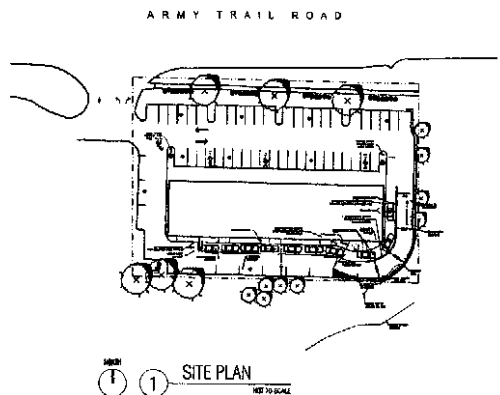

SITE PLAN NOT TO SCALE

BUILDING CODES & ZONING ANALYSIS:

Table with columns: PROPERTY INFO, BUILDING CODES & ZONING ANALYSIS, ARTICLE REFERENCES, and FIRE RATING REQUIREMENT. Includes details on building type, use, and various code references.

ARCHITECTS CERTIFICATION

THIS IS TO CERTIFY THAT I AM A LICENSED ARCHITECT BY THE STATE OF ILLINOIS AND THAT THESE DRAWINGS, SPECIFICATIONS AND SCHEDULES I HAVE DRAWN OR SUPERVISED THE DRAWING OF, AND THAT I AM A LICENSED ARCHITECT BY THE STATE OF ILLINOIS AND THAT THESE DRAWINGS, SPECIFICATIONS AND SCHEDULES I HAVE DRAWN OR SUPERVISED THE DRAWING OF, AND THAT I AM A LICENSED ARCHITECT BY THE STATE OF ILLINOIS AND THAT THESE DRAWINGS, SPECIFICATIONS AND SCHEDULES I HAVE DRAWN OR SUPERVISED THE DRAWING OF...

ENERGY CODE STATEMENT

I CERTIFY THAT I AM THE REGISTERED ENERGY PROFESSIONAL (REP) FOR THIS PROJECT. I ALSO CERTIFY TO THE BEST OF MY PROFESSIONAL KNOWLEDGE AND BELIEF THAT THE ATTACHED PLANS FOR 222 W. ARMY TRAIL RD. CAROL STREAM, ILLINOIS COMPLY WITH THE ENERGY CONSERVATION ACT EFFECTIVE APRIL 22, 2015.

SCOPE OF WORK

INTERIOR RENOVATION OF EXISTING VANILLA BOX TO PROVIDE NEW DRIVE THRU ONLY WINDOW AND INTERIOR ALTERATION FOR COFFEE SHOP USE.

NOTE: THE ARCHITECT HAS CONDUCTED VISUAL SURVEYS OF THE PROJECT SITE AND HAS OBSERVED THE EXISTING CONDITIONS. THE ARCHITECT HAS CONDUCTED VISUAL SURVEYS OF THE PROJECT SITE AND HAS OBSERVED THE EXISTING CONDITIONS. THE ARCHITECT HAS CONDUCTED VISUAL SURVEYS OF THE PROJECT SITE AND HAS OBSERVED THE EXISTING CONDITIONS.

SHEET LIST

NOTE: SCHEDULED SYSTEM BY OWNER BY OTHERS. FINISHES BY OWNER BY OTHERS. SHOP DRAWINGS BY INSTALLER BY OTHERS.

OCCUPANT LOAD CALCULATIONS:

GROUP 1A, MERCHANTILE: TOTAL FLOOR AREA: 1500 SQFT. OCCUPANT LOAD: 200 PERSONS. 200 PERSONS / 200 = 1.0 OCCUPANT APPROX. MERCHANTILE BRIDGE: 30 PERSONS. 30 PERSONS / 25 = 1.2 OCCUPANT APPROX. TOTAL MAXIMUM OCCUPANT LOAD = 28 OCCUPANT APPROX.

PARKING CALCULATIONS:

ORDINANCE: § 16-13-3 SCHEDULE OF PARKING REQUIREMENTS. RESTAURANT - FAST FOOD WITH SEAT DOWN (DRIVE THRU): MIN. DRIVE THRU STANDING SPACES REQUIRED: 10. MIN. DRIVE THRU STANDING SPACES PROVIDED: 10. MIN. CAR PARKING FOR SEAT DOWN (175 SQFT @ 25 SQFT) = 175 = 10 APPROX. TOTAL CAR PARKING AVAILABLE = 10. MIN. ACCESSIBLE CAR PARKING AVAILABLE = 3.

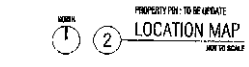

PROJECT DIRECTORY:

PROJECT TITLE: HITEESH PATEL, DUNKIN DONUT W/ DRIVE THRU
PROJECT ADDRESS: 222 W. ARMY TRAIL RD. CAROL STREAM, IL
ARCHITECT: HITEESH PATEL

PROJECT ARCHITECT: HITEESH PATEL
PROJECT OWNER: HITEESH PATEL
PROJECT SITE: 222 W. ARMY TRAIL RD. CAROL STREAM, IL

NOTICE OF COPYRIGHT: THIS DOCUMENT AND THE CONTENTS HEREIN ARE THE PROPERTY OF THE ARCHITECT AND ARE TO BE USED ONLY FOR THE PROJECT AND SITE SPECIFICALLY IDENTIFIED HEREIN. ANY REPRODUCTION OR TRANSMISSION OF THIS DOCUMENT OR THE CONTENTS HEREIN WITHOUT THE WRITTEN PERMISSION OF THE ARCHITECT IS STRICTLY PROHIBITED.

NOTE: DRAWINGS ARE NOT TO SCALE IF SHEET IS PLOTTED ON 11" x 17"

Vertical sidebar containing studio silver ARCHITECTURE AGENCY logo, contact information, and project details including 'SCHEMATIC SITE PLANS AND ZONING ANALYSIS' and 'DRIVE-THRU'.

ARMY TRAIL ROAD

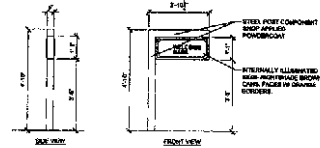
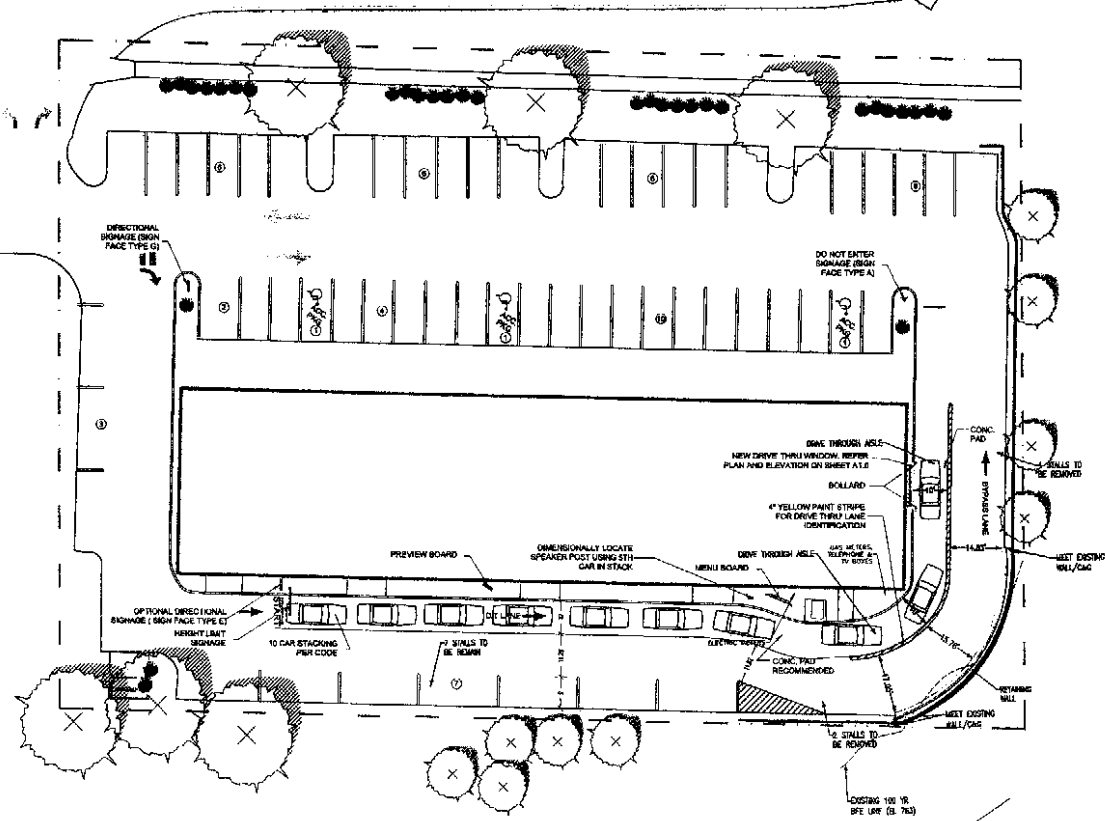

AREA OF SIGN MESSAGE
 LETTERING 1/2" X 1 1/2" X 20"

SIGNAL NOTES
 NOTE: SEE SIGNAGE MESSAGE VERTICAL MESSAGE BOARD FOR DETAILS.

BE USE ONE MESSAGE NOTE:
 PLEASE NOTE THAT DRAWING DOES NOT INDICATE THE LOCATION OF ANY SIGNAGE. ALL SIGNAGE SHALL BE INSTALLED IN ACCORDANCE WITH THE ILLINOIS SIGNAGE REGULATIONS AND THE ILLINOIS SIGNAGE REGULATIONS. ALL SIGNAGE SHALL BE INSTALLED IN ACCORDANCE WITH THE ILLINOIS SIGNAGE REGULATIONS AND THE ILLINOIS SIGNAGE REGULATIONS.

NOT USED	NOT USED	NOT USED	NOT USED
NOT USED	NOT USED	NOT USED	NOT USED

2 SIGNAGE DETAILS
 SCALE: 3/4" = 1'-0"

1 FINAL PUD PLAN (REVISED)
 SCALE: 1" = 20'

PARKING TABLE

	NO OF PARKING SPACES	NO OF REMOVED SPACES	NO OF TOTAL SPACES
EXISTING CURRENT	3	55	58
PROPOSED	3	55	58

THESE PLANS ARE CONFIDENTIAL PROPERTY OF DUNKIN' BRANDS, INC. UNDER RESTRICTED ACCESS.

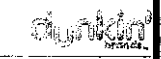

studio silver
 ARCHITECTURE - 30258
 150 N. MORGAN AVE. CHICAGO ILLINOIS
 PH: 312.847.7200 | FAX: 312.848.2206
 EMAIL: INFO@STUDIO-SILVER.COM
 ARCHITECT'S CERTIFICATION
 VILLAGE OF CAROL STREAM

Nahmi Karam, AIA
 4000 Lakeside Dr. #2220
 Evanston, IL 60201

NO.	DESCRIPTION	DATE	SCALE	DRAWN	CHECK	APPD.
1	PRELIMINARY	08/23/15	1/8" = 1'-0"			
2	REVISION	08/23/15	1/8" = 1'-0"			
3	REVISION	08/23/15	1/8" = 1'-0"			

DD - THEME TO BE UPDATED
 DRIVE-THRU
FINAL PUD PLAN (REVISED)
 222 W ARMY TRAIL RD CAROL STREAM IL
 PC NUMBER: 340850

SP-1.0
 Exhibit B

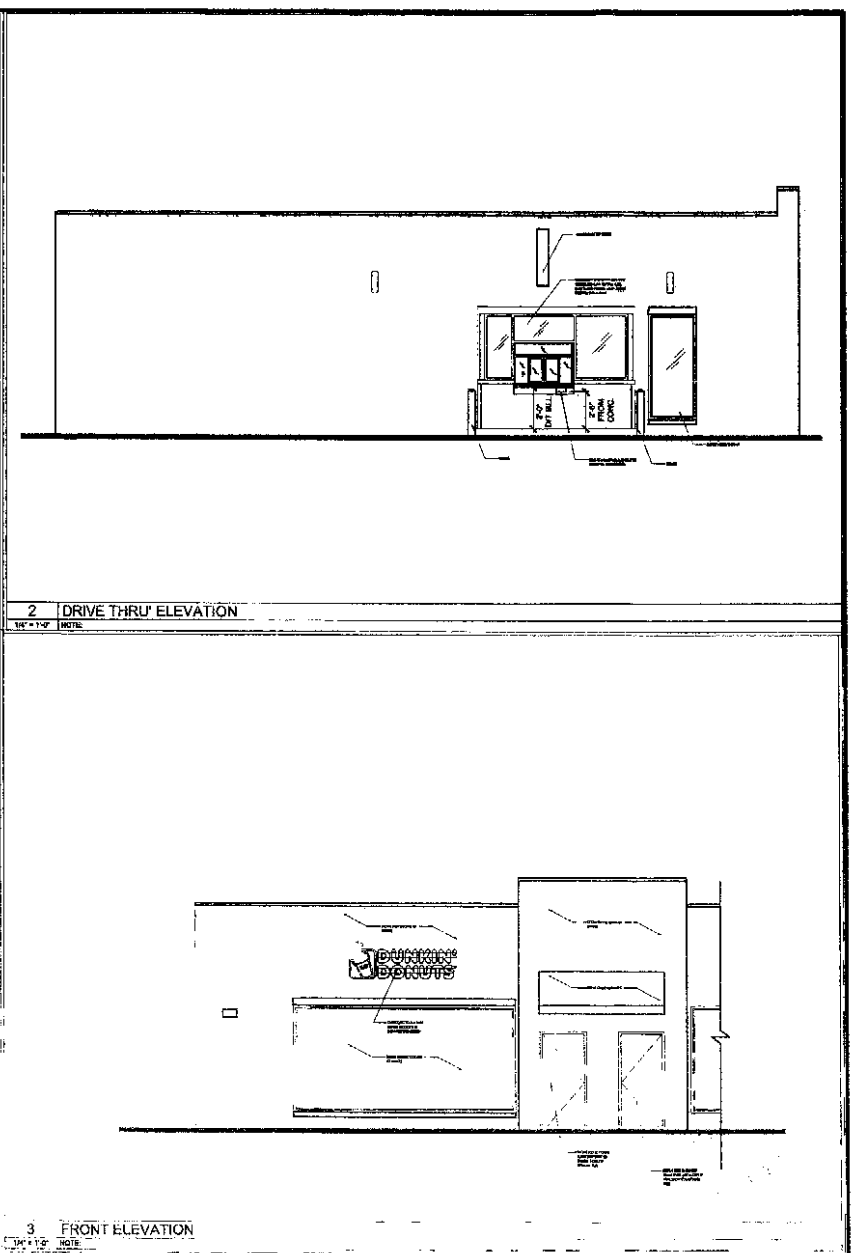
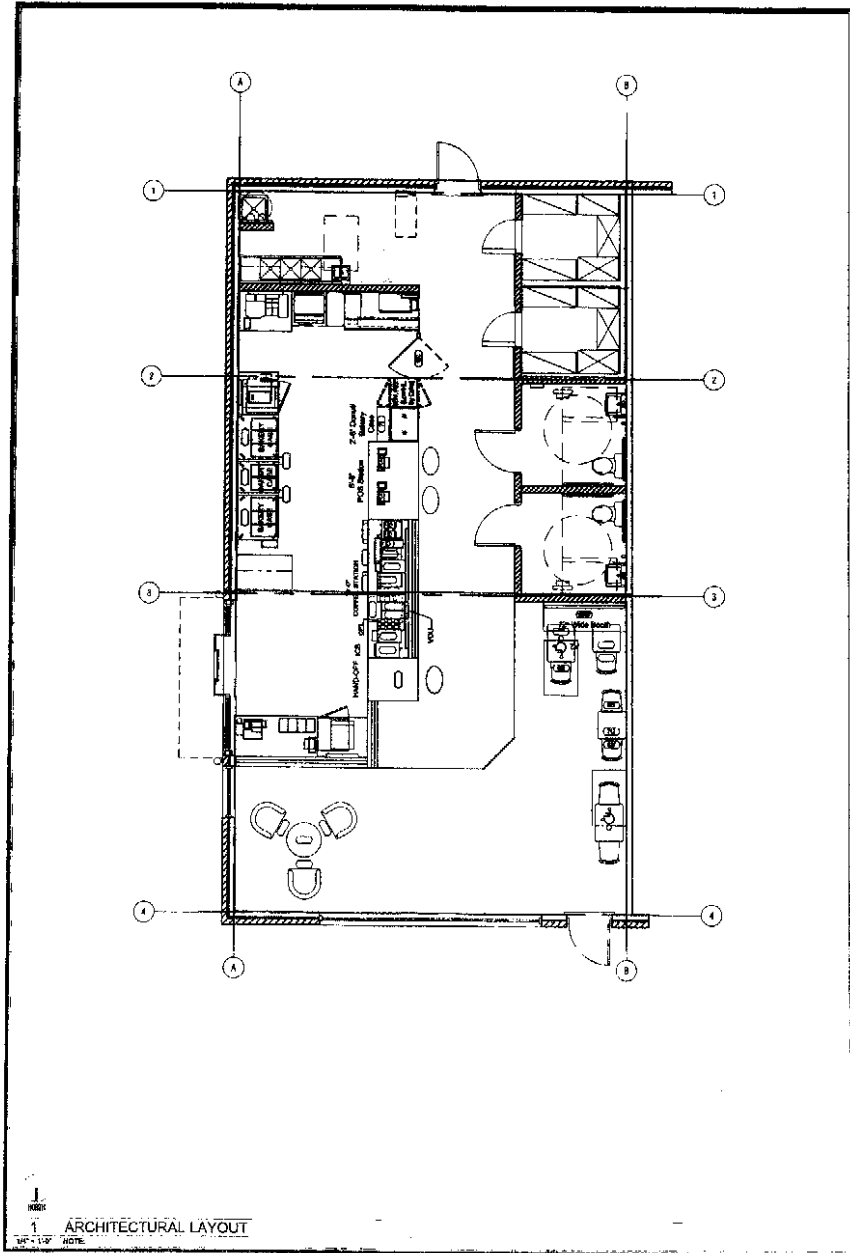

2 DRIVE THRU ELEVATION
1/8" = 1'-0"
DATE: _____
NOTE: _____

THESE PLANS ARE CONFIDENTIAL PROPERTY OF DUNKIN' DONUTS, INC. UNDER RESTRICTED ACCESS.



studio silver
ARCHITECTURE DESIGN

1511 N. MONROE AVE. CHICAGO, ILLINOIS
PH: 312.842.7738 | FAX: 630.899.2726
EMAIL: INFO@STUDIOSILVER.COM
WWW.STUDIOSILVER.COM

ARCHITECTS CERTIFICATION
I am a duly licensed architect in the State of Illinois and certify that I am the author of these plans and that they were prepared by me or under my direct supervision and that I am a duly licensed architect in the State of Illinois.

Validated Signature: A.A.A.
Issued License: 010-002261
Expiration: 11-2016

NO.	DESCRIPTION	DATE	DATE	SCALE	DRAWN	CHECK	APPD.
1	PRELIM.	8/23/15	8/23/15				
2	REVISION	1/13/16					
SHEET REVISIONS							

DD - THEME TO BE UPDATED
DRIVE-THRU

ARCHITECTURAL LAYOUT

FIRST FLOOR

2222 W ARMY TRAIL RD. CAROL
-STREAM/AULI 60188-
PC NUMBER: 340859

A1.0

Exhibit C

THIS DESIGN IS THE ORIGINAL AND UNPUBLISHED WORK OF HILTON DISPLAYS AND MAY NOT BE REPRODUCED, COPIED, OR EXHIBITED IN ANY FASHION WITHOUT WRITTEN CONSENT FROM AN AUTHORIZED OFFICER OF THE COMPANY. © HILTON DISPLAYS 2014

HILTON DISPLAYS

106 W. Summit Hill Dr. • Knoxville TN 37902
 P 800 353 9132 • F 864 242 2204
 email: dunlinsigns@hiltondisplays.com

PART NUMBER

DD-DT-MB-NS

DESCRIPTION

2 PANEL DD MENUBOARD
 NO SPEAKER

CUSTOMER CONTACT

Michele Inglese

SALESMAN / PM

Preston Smith

DESIGNER

B.PERRY

DWG. DATE

10-16-14

REV. DATE / REVISION

06-19-15 10" Depth
 07-22-15 8" Depth angle cover

SCALE

As Noted

DD DRAWING #

DT-1

NGSS EXTERIOR MENUBOARD W/O SPEAKER

DESIGN SPECIFICATIONS ACCEPTED BY:

EST: CLIENT:

SLS/PM: LANDLORD:

THE INTENT OF THIS DRAWING IS TO SHOW A CONCEPTUAL REPRESENTATION OF THE PROPOSED SIGNAGE. DUE TO VARIATIONS IN PRINTING DEVICES AND SUBSTRATES, THE FINISHED PRODUCT MAY DIFFER SLIGHTLY FROM DRAWING.

Underwriters Laboratories Inc.

DRY
 DAMP
 WET

BASE PLATE # 1

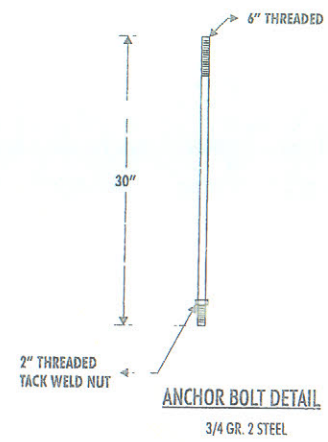
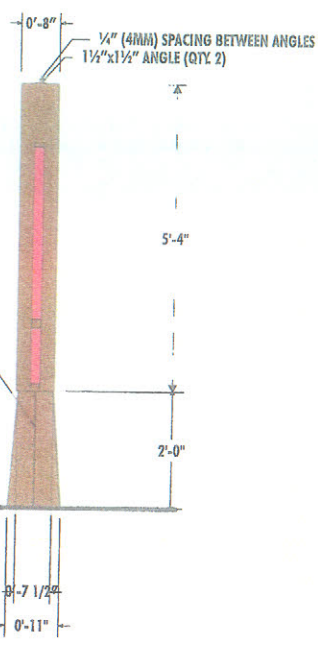
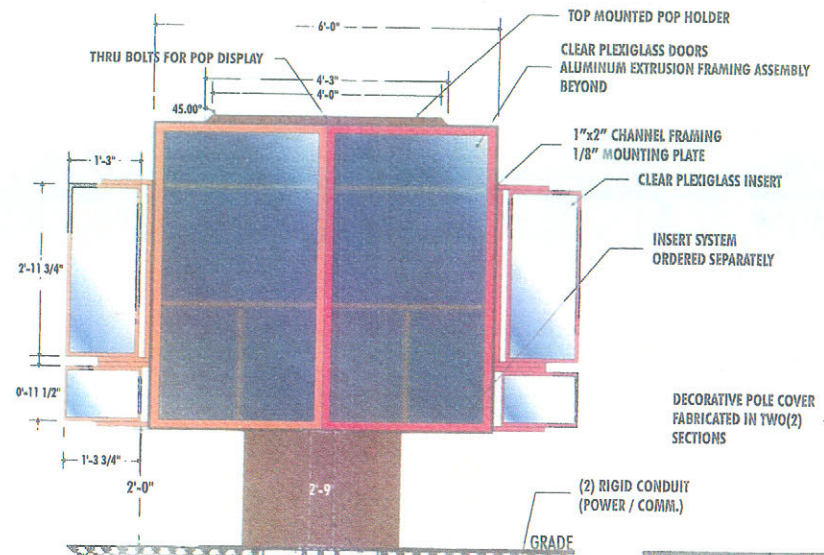

COLOR LEGEND	
PAINT CODE	WALL
ORANGE	3M 3630-3123
MAGENTA	3M 3630-1379
BLUE	3M 3630-8508
BROWN	3M 3630-59
DM 2116-10	N/A
PMS 165	N/A

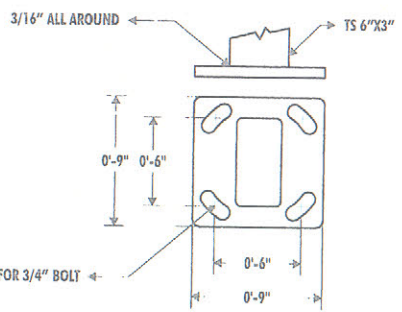
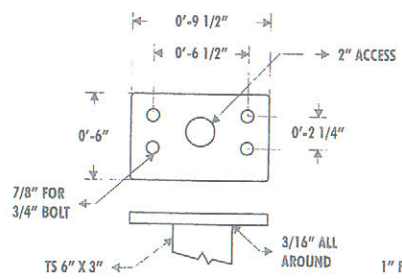
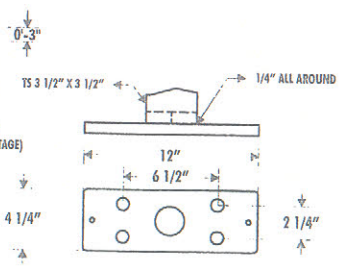
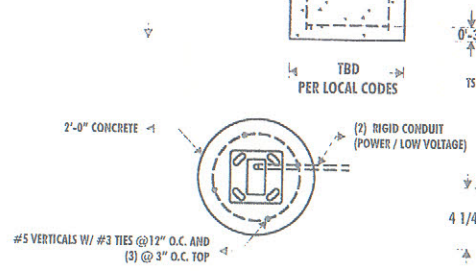
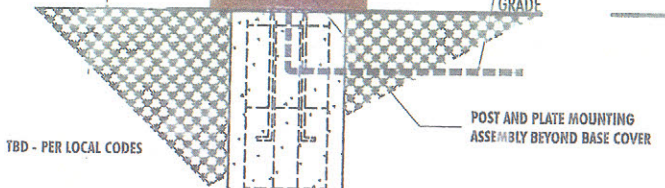

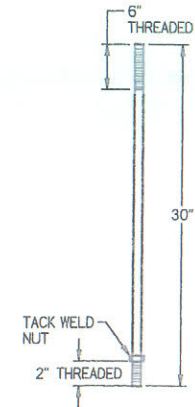
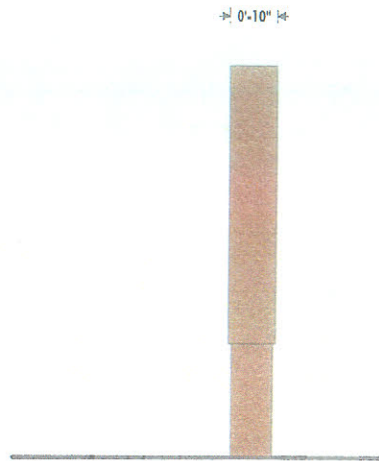
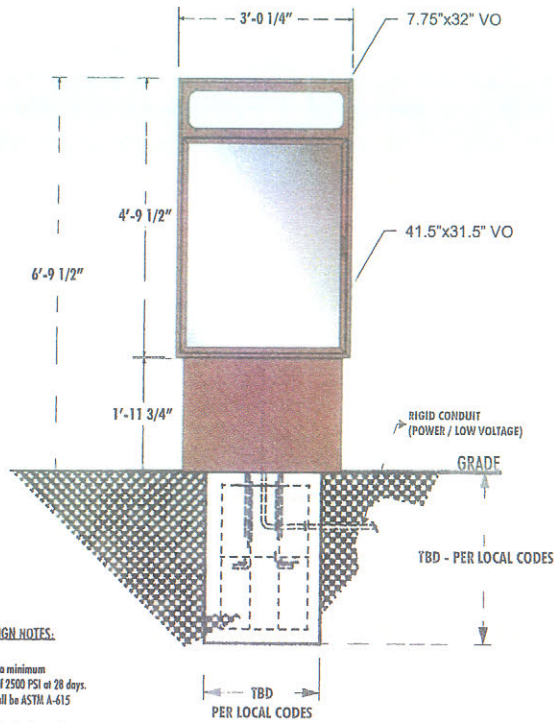

DETAIL C
ANCHOR BOLT
3/4" Gr. 2 STEEL

FOUNDATION DESIGN NOTES:

1. Concrete shall have a minimum compressive strength of 2500 PSI at 28 days.
2. Reinforcing steel shall be ASTM A-615 grade 60.
3. Caisson footing designed using a soil bearing force of 300 PSF per foot lateral. If this soil condition does not exist, it is the Erector's responsibility to have a new base design for the existing soil conditions by a Licensed Structural Engineer.
4. Anchor bolts shall be AASHTO Gr. 2.

DESIGN WINDLOAD:

90MPH IBC 2009 EXPOSURE C
SOIL CLASS 4

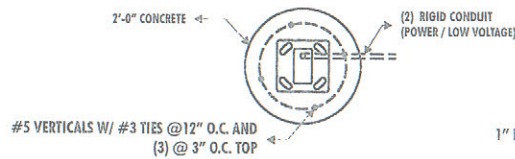

FOOTING PLAN VIEW

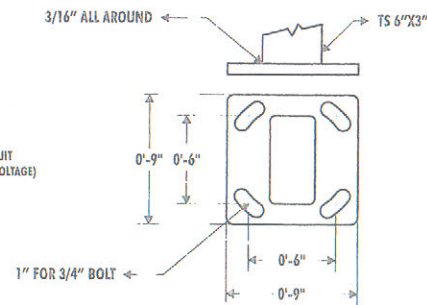

BASE PLATE DETAIL
3/4 ASTM A-36 STEEL

HILTONDISPLAYS

125 HILLSIDE DRIVE • GREENVILLE SC 29607
P 800 353 9132 • F 864 242 2204
www.hiltondisplays.com

PART NUMBER

DD-DT-RPB

DESCRIPTION

DUNKIN DONUTS ILLUMINATED
ROTATING PREVIEW BOARD

COLOR LEGEND

PMS PAINT	VINYL
PMS165C	3M 3630-3123
DD MAGENTA	3M 3630-1379
DD BROWN	3M 3630-59
BM 2116-10	

DESIGNER DWG. DATE

B.PERRY 4-15-15

REV. DATE / REVISION

X-XX-XX XXXXXX

SCALE

1"=24"

DD DRAWING #

DT-6

DRIVE THRU ROTATING PREVIEW BOARD

DESIGN SPECIFICATIONS ACCEPTED BY:

EST: CLIENT:
SLS/P/E: LANDLORD:

THE INTENT OF THIS DRAWING IS TO SHOW A CONCEPTUAL REPRESENTATION OF THE PROPOSED SIGNAGE. DUE TO VARIATIONS IN PRINTING DEVICES AND SUBSTRATES, THE FINISHED PRODUCT MAY DIFFER SLIGHTLY FROM DRAWING.

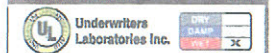

BASE PLATE # 1

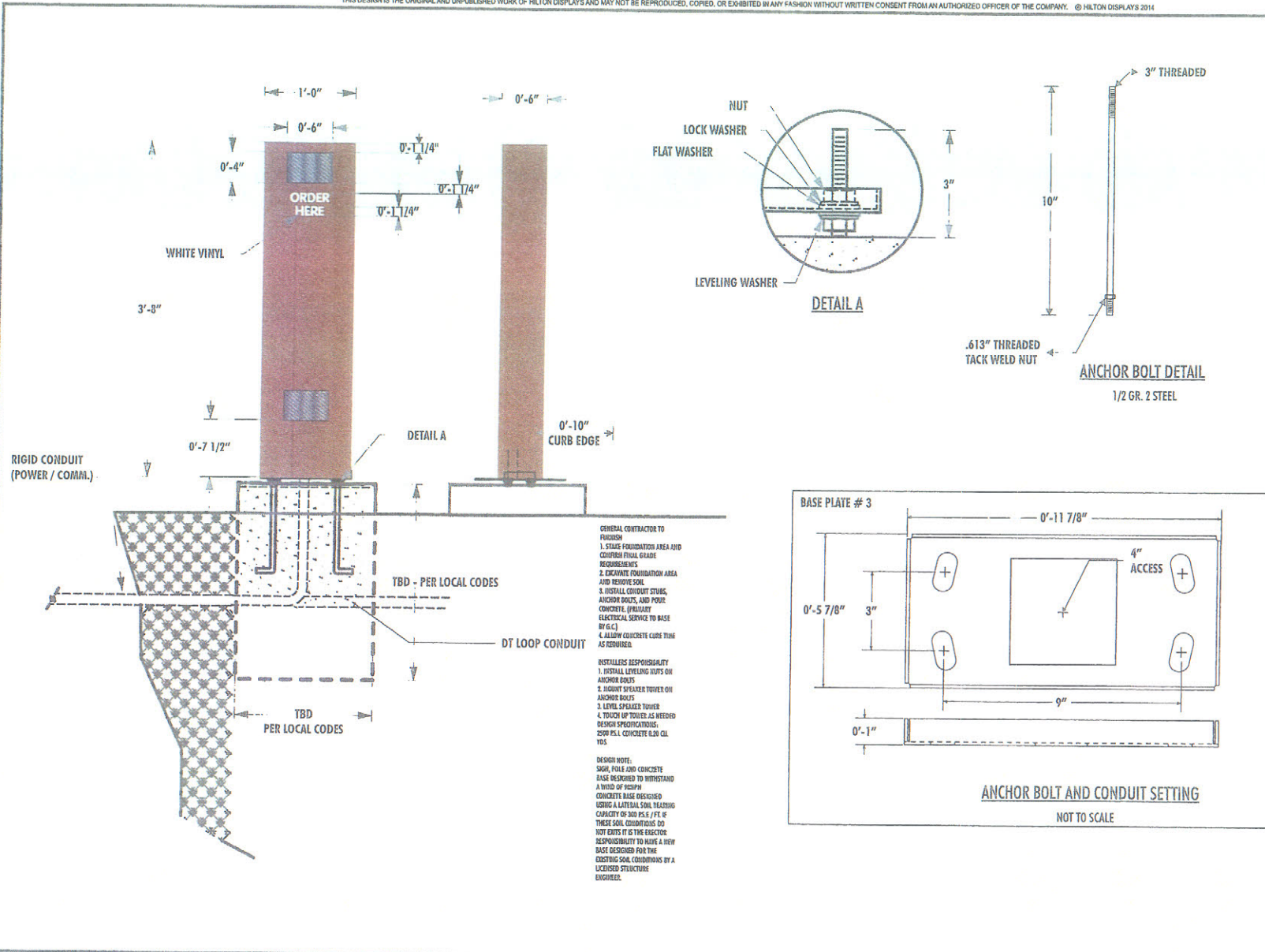

GENERAL CONTRACTOR TO FINISH

1. STAKE FOUNDATION AREA AND CONDUIT FINAL GRADE REQUIREMENTS
2. EXCAVATE FOUNDATION AREA AND REMOVE SOIL
3. INSTALL CONDUIT STUBS, ANCHOR BOLTS, AND POUR CONCRETE (PRIMARY ELECTRICAL SERVICE TO BASE BY E.C.)
4. ALLOW CONCRETE CURE TIME AS REQUIRED.

INSTALLER'S RESPONSIBILITY

1. INSTALL LEVELING NUTS ON ANCHOR BOLTS
2. MOUNT SPEAKER TOWER ON ANCHOR BOLTS
3. LEVEL SPEAKER TOWER
4. TOUCH UP TOOLS AS NEEDED DESIGN SPECIFICATIONS: 2500 P.S.I. CONCRETE & 8000 C.I. TOL.

DESIGN NOTE:

SOIL, POLE AND CONCRETE BASE DESIGNED TO WITHSTAND A WIND OF 50 MPH CONCRETE BASE DESIGNED USING A LATERAL SOIL RESISTING CAPACITY OF 300 P.S.F. / FT. IF THESE SOIL CONDITIONS DO NOT EXIST IT IS THE ERECTOR'S RESPONSIBILITY TO HAVE A NEW BASE DESIGNED FOR THE EXISTING SOIL CONDITIONS BY A LICENSED STRUCTURE ENGINEER.

HILTONDISPLAYS
 125 HILLSIDE DRIVE • GREENVILLE SC 29607
 P 800 353 9132 • F 864 242 2204
 www.hiltondisplays.com

PART NUMBER
DD-DT-ST

DESCRIPTION
 DUNKIN DONUTS STAND ALONE
 SPEAKER TOWER

COLOR LEGEND

PMS/PART	VINYL
PMS165C	3M 3630-3123
DD MAGENTA	3M 3630-1379
DD BROWN	3M 3630-59
BM 2116-10	

DESIGNER DWG. DATE
 B.PERRY 4-15-15

REV. DATE / REVISION

6-17-15	BASEPLATE
8-05-15	BASEPLATE

SCALE
 1"=12"

DD DRAWING #

DT-5
 DRIVE THRU SPEAKER TOWER

DESIGN SPECIFICATIONS ACCEPTED BY:

EST: CLIENT:
 SLS/PM: LANDLORD:

THE INTENT OF THIS DRAWING IS TO SHOW A CONCEPTUAL REPRESENTATION OF THE PROPOSED SIGNAGE. DUE TO VARIATIONS IN PRINTING DEVICES AND SUBSTRATES, THE FINISHED PRODUCT MAY DIFFER SLIGHTLY FROM DRAWING.

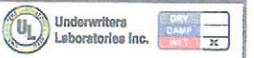

THIS DESIGN IS THE ORIGINAL AND UNPUBLISHED WORK OF HILTON DISPLAYS AND MAY NOT BE REPRODUCED, COPIED, OR EXHIBITED IN ANY FASHION WITHOUT WRITTEN CONSENT FROM AN AUTHORIZED OFFICER OF THE COMPANY. © HILTON DISPLAYS 2014

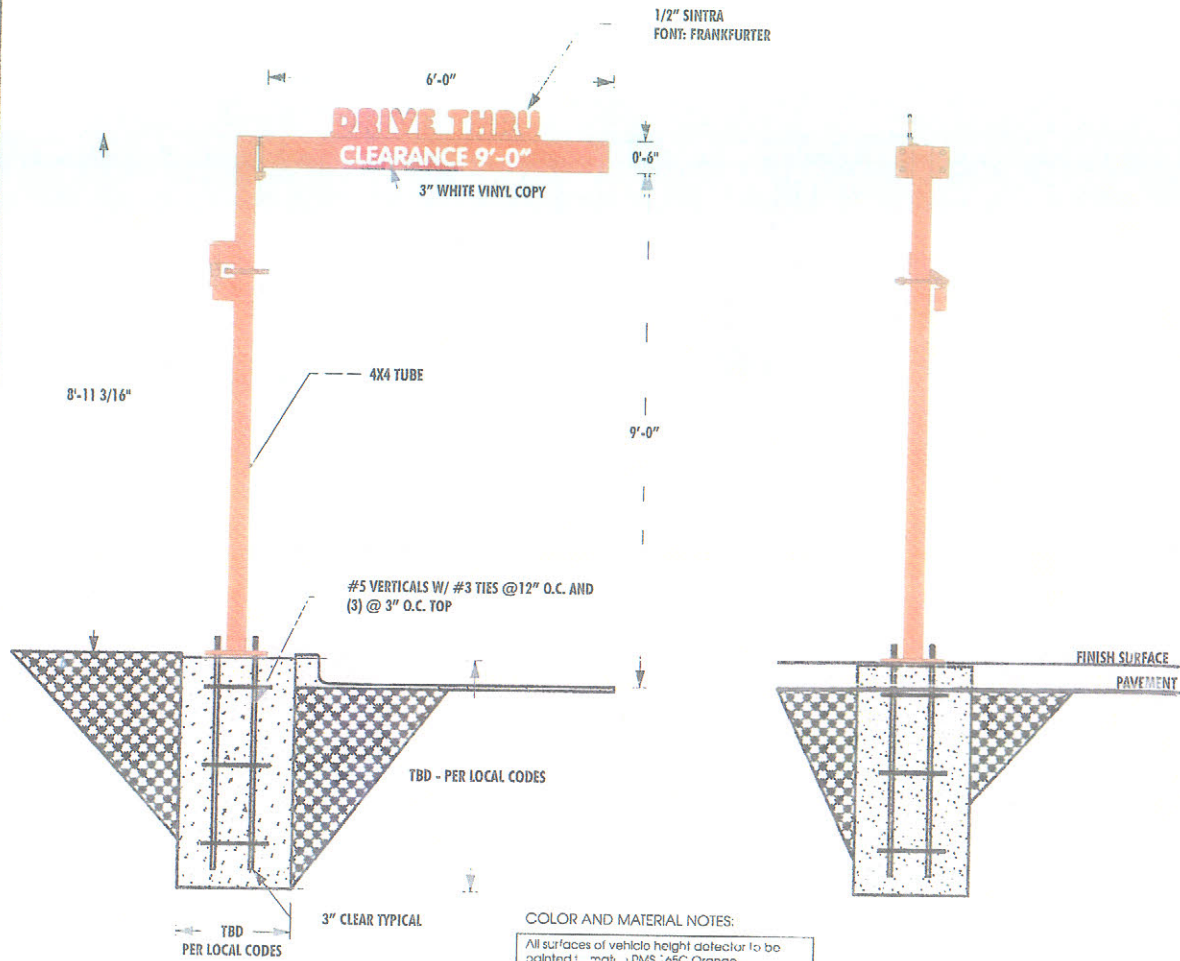

COLOR AND MATERIAL NOTES:
 All surfaces of vehicle height detector to be painted with PMS 165C Orange
 Clearance copy to be white vinyl applied to front of clearance bar
 DRIVE THRU letters to be 1/2" Sintra material, ptd. to match PMS 165C Orange
 NOTE: For overall height, clearance of drive thru window from lowest point drive thru lane is required to be supplied by customer.

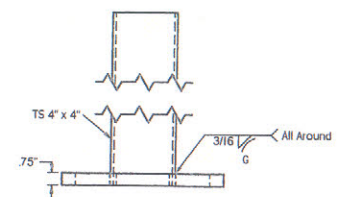
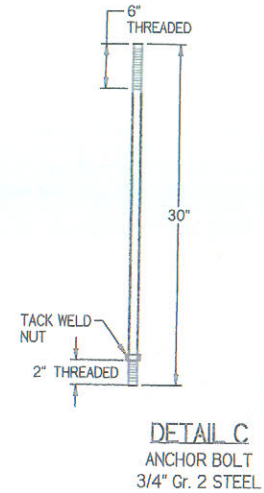

DETAIL A
 PLAN VIEW
 BASE PLATE
 3/4" ASTM A-36 STEEL
 BASE PLATE # 1

HILTONDISPLAYS
 125 HILLSIDE DRIVE • GREENVILLE SC 29607
 P 800 353 9132 • F 864 242 2204
 www.hiltondisplays.com

PART NUMBER	
DD-DT-CB	
DESCRIPTION	
DUNKIN DONUTS HEIGHT DETECTION BAR	
COLOR LEGEND	
PMS PAINT	VINYL
PMS165C	3M 3630-3123
DD MAGENTA	3M 3630-1379
DD BROWN	3M 3630-59
BM 2118-10	

DESIGNER	DWG. DATE
B.PERRY	4-15-15
REV. DATE / REVISION	
X-XX-XX	XXXXXX

SCALE
1"=24"
DD DRAWING #
SS-7

DESIGN SPECIFICATIONS ACCEPTED BY:
EST: CLIENT:
SLS/PM: LANDLORD:

THE INTENT OF THIS DRAWING IS TO SHOW A CONCEPTUAL REPRESENTATION OF THE PROPOSED SIGNAGE. DUE TO VARIATIONS IN PRINTING DEVICES AND SUBSTRATES, THE FINISHED PRODUCT MAY DIFFER SLIGHTLY FROM DRAWING.

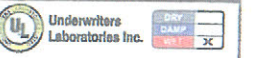

Village of Carol Stream
Interdepartmental Memo

TO: Mayor and Trustees
FROM: Joseph E. Breinig, Village Manager 
DATE: March 3, 2016
RE: Liquor Licensing – 552 N. Gary Avenue

Attached for your review and consideration is an Ordinance reducing the number of Class A Liquor Licenses by one and increasing the number of Class A Liquor Licenses by one. Spectator's Pub & Grill, Inc., 552 N. Gary Avenue is being sold to Chrissy's LLC at 552 N. Gary Avenue. The new business will be known as Chrissy's.

The application submitted by Chrissy's LLC has been found to be in order. Staff recommends approval pending satisfaction of background checks with a May 1, 2016 effective date.

JEB/dk

Attachments

ORDINANCE NO. _____

**AN ORDINANCE AMENDING CHAPTER 11, ARTICLE 2 OF THE CAROL STREAM
CODE OF ORDINANCES BY DECREASING THE NUMBER OF CLASS A LIQUOR
LICENSES FROM 10 TO 9 (SPECTATOR'S PUB & GRILL, INC. D/B/A
SPECTATOR'S PUB & GRILL, 552 N. GARY AVE.) AND INCREASING THE
NUMBER OF CLASS A LIQUOR LICENSES FROM 9 TO 10
(CHRISSY'S LLC d/b/a CHRISSY'S, 552 N. GARY AVE.)**

BE IT ORDAINED BY THE MAYOR AND BOARD OF TRUSTEES OF THE
VILLAGE OF CAROL STREAM, DUPAGE COUNTY, ILLINOIS, IN THE EXERCISE OF
ITS HOME RULE POWERS; as follows:

SECTION 1: That Chapter 11, Article 2 of the Carol Stream Code of Ordinances,
Classification of Liquor Licenses, be and the same is hereby amended by decreasing the number
of Class A Liquor Licenses, from 10 to 9.

SECTION 2: That Chapter 11, Article 2 of the Carol Stream Code of Ordinances,
Classification of Liquor Licenses, be and the same is hereby amended by increasing the number
of Class A Liquor Licenses from 9 to 10.

SECTION 3: This Ordinance amending Chapter 11 of the Code of Ordinances of the
Village of Carol Stream shall be reprinted in the loose-leaf volume, which bears that title.

SECTION 4: This Ordinance shall be in full force and effect from and after its passage
and approval by law effective May 1, 2016.

PASSED AND APPROVED THIS 7th DAY OF MARCH, 2016.

AYES:

NAYS:

ABSENT:

Frank Saverino, Sr., Mayor

ATTEST:

Laura Czarnecki, Village Clerk

Village of Carol Stream
Interdepartmental Memo

TO: Mayor and Trustees
FROM: Joseph E. Breinig, Village Manager 
DATE: March 3, 2016
RE: Liquor Licensing – 257 W. Elk Trail

Attached for your review and consideration is an Ordinance reducing the number of Class C Liquor Licenses by one and increasing the number of Class C Liquor Licenses by one for Carol Stream Food Mart, 257 W. Elk Trail. Jill & Alisha, Inc. is selling the business to Gita Corporation. The name of the business will remain the same.

The application submitted by Gita Corporation has been found to be in order. Staff recommends approval pending satisfaction of background checks with a May 1, 2016 effective date.

JEB/dk

Attachments

ORDINANCE NO. _____

AN ORDINANCE AMENDING CHAPTER 11, ARTICLE 2 OF THE CAROL STREAM CODE OF ORDINANCES BY DECREASING THE NUMBER OF CLASS C LIQUOR LICENSES FROM 20 TO 19 (JILL & ALISHA INC. d/b/a CAROL STREAM FOOD MART, 257 W. ELK TRAIL) AND INCREASING THE NUMBER OF CLASS C LIQUOR LICENSES FROM 19 TO 20 (GITA CORPORATION d/b/a CAROL STREAM FOOD MART, 257 W. ELK TRAIL)

BE IT ORDAINED BY THE MAYOR AND BOARD OF TRUSTEES OF THE VILLAGE OF CAROL STREAM, DUPAGE COUNTY, ILLINOIS, IN THE EXERCISE OF ITS HOME RULE POWERS; as follows:

SECTION 1: That Chapter 11, Article 2 of the Carol Stream Code of Ordinances, Classification of Liquor Licenses, be and the same is hereby amended by decreasing the number of Class C Liquor Licenses, from 20 to 19.

SECTION 2: That Chapter 11, Article 2 of the Carol Stream Code of Ordinances, Classification of Liquor Licenses, be and the same is hereby amended by increasing the number of Class C Liquor Licenses from 19 to 20.

SECTION 3: This Ordinance amending Chapter 11 of the Code of Ordinances of the Village of Carol Stream shall be reprinted in the loose-leaf volume, which bears that title.

SECTION 4: This Ordinance shall be in full force and effect from and after its passage and approval by law effective May 1, 2016.

PASSED AND APPROVED THIS 7th DAY OF MARCH, 2016.

AYES:

NAYS:

ABSENT:

Frank Saverino, Sr., Mayor

ATTEST:

Laura Czarnecki, Village Clerk

RESOLUTION NO. _____

AGENDA ITEM
3-1 3-7-16

**A RESOLUTION DECLARING SURPLUS PROPERTY
OWNED BY THE VILLAGE OF CAROL STREAM**

WHEREAS, in the opinion of the corporate authorities of the Village of Carol Stream, Illinois, it is no longer necessary or useful, or for the best interests of the Village of Carol Stream to retain ownership of the personal property described in "Exhibit A"; and

WHEREAS, the described personal property has been determined by the corporate authorities of the Village of Carol Stream to have negligible value to the Village; and

WHEREAS, it has been determined by the Mayor and Board of Trustees of the Village of Carol Stream to dispose of the surplus property.

NOW, THEREFORE, BE IT RESOLVED BY THE MAYOR AND BOARD OF TRUSTEES OF THE VILLAGE OF CAROL STREAM, DUPAGE COUNTY, ILLINOIS, IN THE EXERCISE OF ITS HOME RULE POWER, as follows:

SECTION 1: That the Mayor and Board of Trustees of the Village of Carol Stream find that the personal property described in Exhibit "A", now owned by the Village of Carol Stream, is no longer useful and authorize its disposal per the attached memorandum dated March 1, 2016.

SECTION 2: This resolution shall be in full force and effect from and after its passage and approval in the manner provided by law.

PASSED AND APPROVED THIS 7th DAY OF MARCH, 2016.

AYES:

NAYS:

ABSENT:

Frank Saverino, Sr., Mayor

ATTEST:

Laura Czarniecki, Village Clerk

EXHIBIT "A"

Village of Carol Stream
Interdepartmental Memo

TO: Joseph Breinig, Village Manager
FROM: Tia Messino, Management Analyst
DATE: March 1, 2016
RE: Surplus Equipment

The Department has identified the equipment below to be declared surplus:

Set of 4 Hubcaps **2015 Ford F550**
These hubcaps came with a recent truck purchase but were replaced as part of the Public Works operational outfitting of the vehicle. They do not have value to the Village but may have value at auction.

Idler Pulley and Bracket **2015 Ford F550**
The idler pulley and bracket came with a recent truck purchase but were replaced as part of the Public Works operational outfitting of the vehicle. They do not have value to the Village but may have value at auction.

Two Metal Cabinets **Borg Warner**
Due to improvement in equipment these items no longer have value to the Village but may have value at auction or as scrap.

Misc. Electronics
Due to the equipment no longer being effective, these items no longer have value to the Village but may have value at auction or as scrap.

1 disk drive **RGEA025137WL**
2 Hughes Cable box/DVRs **SD-DVR40 & SD-HBH**
Coby DVD player **DVD-233**
1 Damaged Radio

Staff recommends that these items be declared surplus by the Mayor and Board of Trustees and that the Public Works Director be authorized to dispose of the items.

Ford Hubcaps

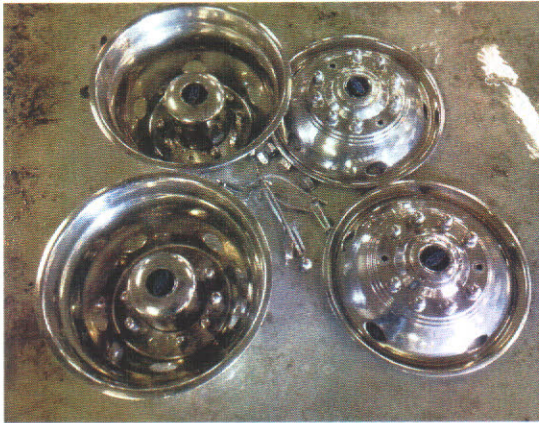

Ford Pulley & Bracket

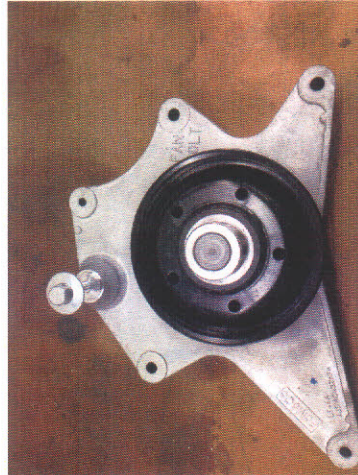

Miscellaneous Electronics



Pair of Metal Cabinets



**A RESOLUTION DECLARING SURPLUS PROPERTY
OWNED BY THE VILLAGE OF CAROL STREAM**

WHEREAS, in the opinion of the Corporate Authorities of the Village of Carol Stream, Illinois, it is no longer necessary or useful, or for the best interests of the Village of Carol Stream to retain ownership of the personal property described; and

WHEREAS, the described personal property has been determined by the Corporate Authorities of the Village of Carol Stream to have negligible value to the Village; and

WHEREAS, it has been determined by the Mayor and Board of Trustees of the Village of Carol Stream to declare one vehicle as surplus for sale and go to auction through the America's Auto Auction Inc.

NOW, THEREFORE, BE IT RESOLVED BY THE MAYOR AND BOARD OF TRUSTEES OF THE VILLAGE OF CAROL STREAM, DUPAGE COUNTY, ILLINOIS, IN THE EXERCISE OF ITS HOME RULE POWERS, as follows:

SECTION 1: That the Mayor and Board of Trustees of the Village of Carol Stream find that the personal property described below:

- 2003 Ford Crown Victoria (633) VIN: 2FAHP71V29X102230

now owned by the Village of Carol Stream, is no longer useful and authorize its auction per the attached memorandum dated February 22, 2016.

SECTION 2: This Resolution shall be in full force and effect from and after its passage and approval in the manner provided by law.

PASSED AND APPROVED THIS 7th DAY OF MARCH, 2016.

AYES:

NAYS:

ABSENT:

Frank Saverino Sr., Mayor

ATTEST:

Laura Czarnecki Village Clerk

Village of Carol Stream
Interdepartmental Memo

TO: Joe Breinig, Village Manager

REVIEWED AND APPROVED BY: Chief Ed Sailer



FROM: SGT Don Cummings #27



DATE: 2/22/2016

RE: Surplus of squad 633 for auction

Request to declare squad car as surplus for sale via the America's Auto Auction INC.

The below listed vehicle is a retired police squad. This vehicle was taken out of service as a squad last year, and was being utilized as a training car. Due to the vehicle's age, mechanical problems, high mileage, and poor body work, it cannot be properly utilized by any department within the Village. I would like the vehicle declared as surplus so it can go to auction.

- 1) 2003 Ford Crown Victoria (633) 2FAHP71V29X102230
Mileage: 82,553

Village of Carol Stream
Interdepartmental Memorandum

TO: Joseph Breinig, Village Manager
FROM: William N. Cleveland, Assistant Village Engineer 
DATE: March 2, 2016
RE: Acceptance of Schmale and St. Charles Road Watermain Easements

In July of 2014 the Village began the process of obtaining watermain easements from thirty property owners along Schmale and St. Charles Roads. In December of last year, the property owner listed below provided the signed easement document.

<u>Business Name</u>	<u>Address</u>	<u>PIN</u>
Angel Associates LP	381 E. St. Charles Road	05-04-203-019

This February we sent letters to all businesses and property owners advising them that the project was in jeopardy if the remaining easements were not granted. This letter has caused three property owners to contact the Village (Covered Bridge and Autumn Ridge Apartments and the former Pizza Hut property) but there are still key easements needed to construct the watermain.

Unfortunately, final construction drawings cannot be prepared until we are sure all of the easements can be obtained, and our window for bidding and construction this year is rapidly closing. Engineering staff is still pursuing the remaining easements and will continue to personally contact owners and involve the Village Attorney in the process when requested by the property owners.

Engineering staff recommends the resolution accepting this easement be approved and recorded. Additional resolutions for future easements will be brought to the Board for acceptance as they are obtained.

Cc: James Knudsen, Director of Engineering Services
Phil Modaff, Director of Public Works
Adam Frederick, Civil Engineer II
Sherry Craig, Secretary, Clerks Office

RESOLUTION NO. _____

**A RESOLUTION ACCEPTING A GRANT OF A WATER MAIN EASEMENT
(ANGEL ASSOCIATES, LP, 381 E. ST. CHARLES ROAD)**

WHEREAS, the Mayor and Board of Trustees of the Village of Carol Stream have determined that it is in the best interest of the Village to execute an Agreement for Acceptance of a Water Main Easement between Angel Associates, LP, 381 E. St. Charles Road ("Grantor") and the Village of Carol Stream ("Grantee").

NOW, THEREFORE, BE IT RESOLVED BY THE MAYOR AND BOARD OF TRUSTEES OF THE VILLAGE OF CAROL STREAM, DUPAGE COUNTY, ILLINOIS, IN THE EXERCISE OF ITS HOME RULE POWERS, as follows:

SECTION 1: That the Mayor and Village Clerk of the Village of Carol Stream be and the same are hereby authorized to execute the Agreement for Grant of a Water Main Easement, attached hereto as Exhibit "A" and as approved by the Village Attorney. The address of the property is: 381 E. St. Charles Road, Carol Stream, Illinois, with a P.I.N. of 05-04-203-019.

SECTION 2: That the Mayor and the Village Clerk of the Village of Carol Stream be and the same are hereby authorized to execute the Plat of Easement in connection herewith, and direct the Village Clerk to record with the DuPage County Recorder's Office the Agreement for Grant of a Water Main Easement and Plat of Easement.

SECTION 3: That all Resolutions or parts thereof, in conflict with the provisions of this Resolution are, to the extent of such conflict, expressly repealed.

Resolution No. _____
Page 2

SECTION 4: This Resolution shall be in full force and effect from and after its passage and approval as provided by law.

PASSED AND APPROVED THIS 7th DAY OF MARCH, 2016.

AYES:

NAYS:

ABSENT:

Frank Saverino, Sr., Mayor

ATTEST:

Laura Czarnecki, Village Clerk

Prepared by and return to:

Village of Carol Stream
500 N. Gary Avenue
Carol Stream, Illinois 60186
Attn: Village Engineer

GRANT OF WATER MAIN EASEMENT

THIS GRANT OF WATER MAIN EASEMENT ("Grant of Easement") is made this ____ day of _____ 2015, by Angel Associates, LP, (hereinafter referred to as the "Grantor") to the Village of Carol Stream, DuPage County, Illinois (hereinafter referred to as the "Grantee"). Grantor and Grantee are sometimes hereinafter referred to individually as a "Party" and collectively as the "Parties."

WITNESSETH:

WHEREAS, Grantor is the owner of the real property legally described in Exhibit A, attached hereto and made a part hereof (hereinafter referred to as the "Grantor Property"); and

WHEREAS, the Grantee desires to construct a water main, and all facilities incidental thereto, (hereinafter referred to as the "Water Main Improvements") on a portion of the Grantor Property; and

WHEREAS, Grantor has agreed to grant the Grantee the necessary nonexclusive permanent easement and a temporary construction easement relative to the Water Main Improvements, as set forth herein;

NOW, THEREFORE, for and in consideration of Ten and No/100 Dollars (\$10.00) and other good and valuable consideration in hand paid, receipt of which is

hereby acknowledged, the terms and conditions set forth below and the benefits to be derived from this Grant of Easement, the Parties agree as follows:

1. That the recitals set forth above are incorporated herein and made a part hereof as if set forth fully herein.

2. Grantor hereby grants and conveys to the Grantee a nonexclusive perpetual easement and right-of-way (the "Easement"), for the full and free right, privilege and authority to construct, install, reconstruct, replace, remove, repair, alter, inspect, maintain and operate a water main, and all facilities incidental thereto (the "Easement Activities"), in, on, upon, over, through, across the property as legally described in Exhibit A, attached hereto and made a part hereof (the "Easement Premises") and to from time to time, cut down, trim or remove any shrubs, trees, bushes or other plants and to clear obstructions from the surface and subsurface of the Easement Premises that interfere with the operation or access to said Easement Activities.

3. Grantor further grants and conveys to the Grantee a temporary construction easement for the full and free right, privilege and authority to construct and install a water main and all facilities thereto , in, on, upon, over, through, across the property as legally described in Exhibit A, attached hereto and made a part hereof (the "Temporary Easement"). The Temporary Easement shall terminate on the date which is twenty-four (24) months from the date this Grant of Easement is recorded. Grantee acknowledges that there is currently a structure in place upon a portion of the Temporary Easement, and that Grantee shall not disturb, molest, injure or in any manner interfere with any structure in place on the Temporary Easement.

4. Subject to the terms of Paragraph 7, Grantor hereby agrees to and with the Grantee that the officers, agents, employees, successors, grantees, lessees and assigns of the Grantee may, at any and all times designated herein, when necessary and convenient to do so, go in, on, upon, over and across the Grantor Property and the Easement Premises, and do and perform any and all acts necessary or convenient to the carrying into effect the purposes for which this Grant of Easement and the Easement created hereby are made, and that the Grantor shall not disturb, molest, injure or in any manner interfere with the aforesaid water main, and all facilities and activities incidental thereto.

5. The Easement shall be used and enjoyed solely by Grantee and its duly authorized officers, agents, contractors or employees to conduct the Easement Activities in accordance with this Grant of Easement. Grantee shall not assign its rights under this Grant of Easement in whole or in part or grant permission to traverse, enter upon or otherwise use the Easement Premises to any other person or entity without the prior written consent of Grantor.

6. The Grantor reserves the right to use of the Easement Premises, for any lawful purpose, except that any structure or use shall not unreasonably interfere with the Easement or the Easement Activities granted hereunder.

7. The Grantee, its officers, agents, employees, successors, grantees, lessees, contractors and assigns shall promptly, and as soon as practicable after engaging in any Easement Activities, restore to its former condition any portion of the Grantor Property which is disturbed or altered in any manner by such Easement

Activities, at the Grantee's sole cost and expense. The Grantee agrees that for the duration of the construction of the Water Main Improvements and for any and all future improvements, neither the Grantee nor the Grantee's agents or contractors shall block access to the Grantor's facilities and premises, namely, the PRIDE of Carol Stream Carwash and that water to the Grantor's facility will remain undisrupted, during the facility's business operations. Neither the Grantee nor the Grantee's agents or contractors shall park vehicles or store any other materials upon the Grantor Property, Easement and Temporary Easement notwithstanding, without the expressed written consent of the Grantor.

8. All work, labor, services, equipment, tools and materials to be performed, furnished or used directly or indirectly in, or in connection with, the Easement Activities, and all other matters and things to be performed, furnished or used, or expenses to be paid, under the term of this Grant of Easement, are to be at the sole expense of the Grantee, and all such work shall be performed promptly and completed in each instance with diligence and as soon as reasonably practicable after commencement thereof. Grantee shall not cause or suffer or permit to be created any mechanics' or materialmen's liens or claims against the Grantor Property or the Easement Premises. Grantee shall defend, indemnify and hold harmless Grantor from and against any such claims or liens.

9. Grantee shall obtain all necessary permits and approvals and shall otherwise comply with all applicable federal, state and local laws, rules, regulations and ordinances in the conduct of the Easement Activities.

10. Such perpetual Easement as is herein granted shall run with the land and the covenants, agreements, terms, conditions, obligations, rights and interests herein contained or provided for shall be likewise binding upon and shall inure to the benefit of the Grantor and Grantee, and their respective heirs, executors, successors, grantees, lessees and assigns.

11. Any and all notices or communications given pursuant to Grant of Easement shall be in writing and shall be deemed received on the third business day after being mailed by certified or registered mail, postage prepaid, return receipt requested; or on the next business day after deposit with a nationally-recognized overnight delivery service (such as Federal Express or Airborne) for guaranteed next business day delivery; or by personal delivery; addressed to the Parties as follows:

To Grantor: Angel Associates, LP
 30W180 Butterfield Road
 Warrenville, IL 60555

To Grantee: VILLAGE OF CAROL STREAM
 500 N. Gary Avenue
 Carol Stream, Illinois 60186
 Attn: Village Engineer

12. This Agreement contains the entire agreement between the Parties with respect to the use of the Easement Premises and the Grantor Property by Grantee in connection with the Easement Activities, and cannot be modified except by a writing, dated subsequent to the date hereof, and signed by both Parties.

13. This Agreement is entered into solely for the benefit of the Parties, and nothing in this Agreement is intended, either expressly or impliedly, to provide any right

or benefit of any kind whatsoever to any person and entity who is not a party to this Agreement or to acknowledge, establish or impose any legal duty to any third party.

14. Grantee agrees to indemnify, hold harmless and defend the Grantor from any and all claims, judgments, awards, penalties, fees, costs, expenses and attorneys fees arising out of or as a result of any negligent or willful act or omission of the Grantee, its agents, contractors, employees or personnel relating to the Grant of the Easement and/or the Temporary Easement or relating to any and all work, labor, services, equipment, tools and materials performed or provided by Grantee's agents, contractors, employees or personnel under this agreement.

IN WITNESS WHEREOF, the Grantor has caused its his/her/their name to be signed to these presents the day and year first above written.

Grantor:

Angel Associates, LP

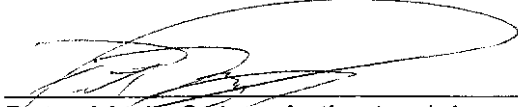

Peter Mario Spina, Authorized Agent

Agreed to and accepted by the Village of Carol Stream, DuPage County, Illinois, this ____ day of _____, 2015.

By: _____
Frank Saverino Sr Mayor

ATTEST: _____
Village Clerk

ACKNOWLEDGMENT

STATE OF ILLINOIS)
) SS
COUNTY OF DUPAGE)

I, the undersigned, a Notary Public, in and for the County and State aforesaid, DO
HEREBY CERTIFY that Peter Maria Spina,
personally known to me to be the same person(s) whose name(s) are subscribed to the
foregoing instrument, appeared before me this day in person and severally
acknowledged that he/she/they signed and delivered the said instrument as their free
and voluntary act, for the uses and purposes therein set forth.

GIVEN under my hand and official seal, this 10 day of November, 2015.



Brian G. Boylan
Notary Public

Exhibit A

LEGAL DESCRIPTION OF GRANTOR PROPERTY

Lot 1 in Final Plat of Subdivision For Carols Court, being a subdivision in section 4, township 39 north, range 10 east of the third principal meridian, according to the plat thereof recorded February 18, 2011 as document number R2011-025415, in DuPage County, Illinois.

LEGAL DESCRIPTION OF PERMANENT EASEMENT PREMISES

The northerly 20.00 feet, as measured along the southerly right of way of St. Charles Road, of Lot 1 in Final Plat of Subdivision For Carols Court, being a subdivision in section 4, township 39 north, range 10 east of the third principal meridian, according to the plat thereof recorded February 18, 2011 as document number R2011-025415, in DuPage County, Illinois.

LEGAL DESCRIPTION OF TEMPORARY EASEMENT

The southerly 10.00 feet of the northerly 30.00 feet, as measured along the southerly right of way of St. Charles Road, of Lot 1 in Final Plat of Subdivision For Carols Court, being a subdivision in section 4, township 39 north, range 10 east of the third principal meridian, according to the plat thereof recorded February 18, 2011 as document number R2011-025415, in DuPage County, Illinois.

EXHIBIT B

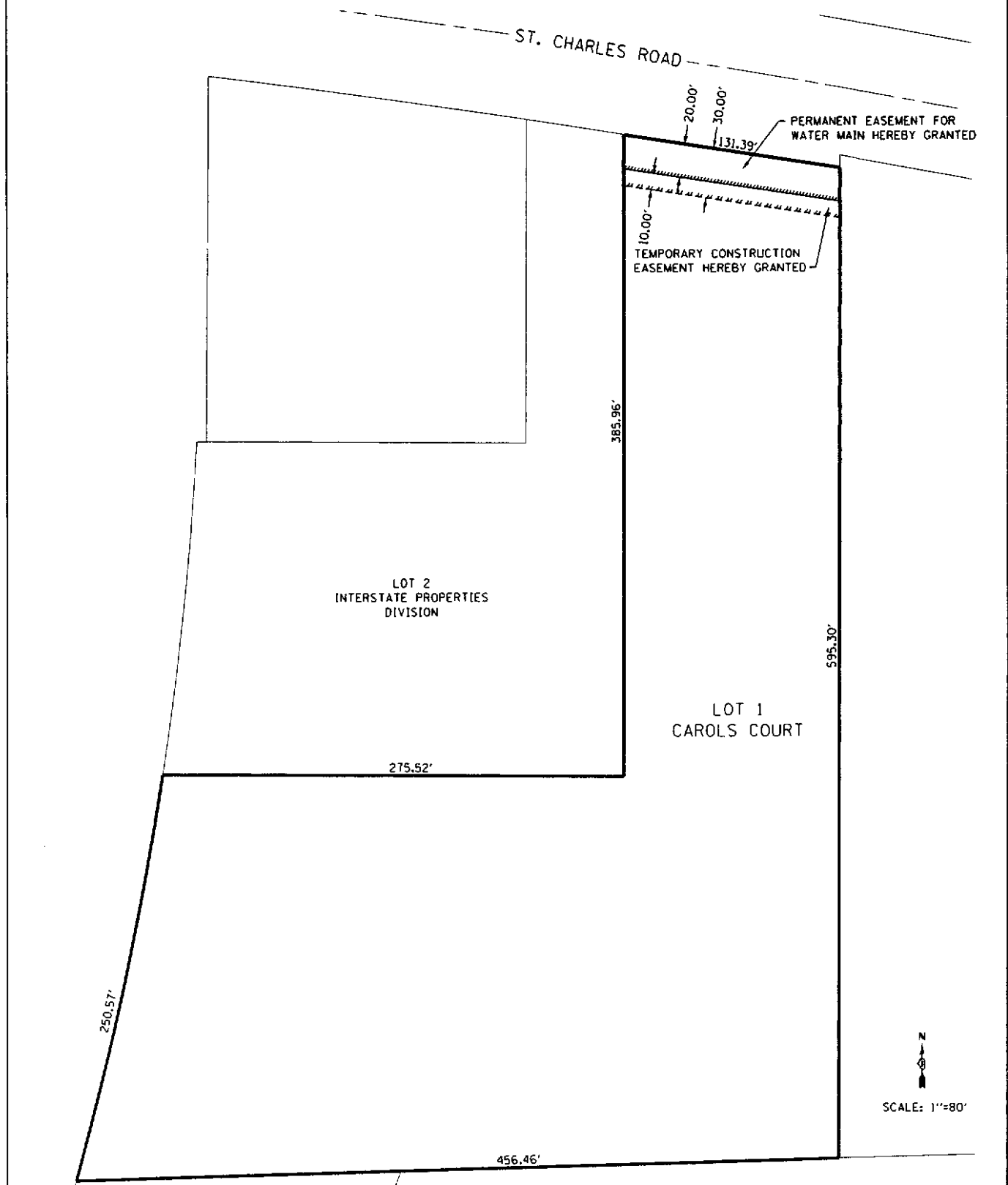

Village of Carol Stream
Interdepartmental Memo

TO: Joe Breinig, Village Manager
FROM: Philip J. Modaff, Director of Public Works
DATE: March 1, 2016
RE: Resolution Supporting Application for ComEd Green Region Grant Funds for the WRC Native Prairie Restoration Project

ComEd, in partnership with Openlands, is offering funding through their annual Green Region Grant funding program which is intended to assist local communities' efforts to plan for, protect, and improve open land by providing funding for some expenses towards these goals. The grants, which can go up to \$10,000 (and no more than 50% of project costs), support existing open space projects that focus on conservation, preservation and improvements to local parks and recreation resources. Grant recipients can use ComEd Green Region grants in combination with other funding sources to cover a portion of the expenses associated with developing and/or supporting their open space programs.

The proposed FY17 budget includes a project to restore a portion of the landscape on the east side of the WRC which has been de-commissioned. The project as originally conceived included simply replacing the turf grass in the east side with a pollinator meadow mix to both reduce maintenance costs and increase habitat for pollinators. The availability of the grant program presents an opportunity for a larger project. A map depicting the proposed project area, which is just less than one acre, is attached.

If grant funds are awarded the project would be expanded to include:

- removal of 950 feet of existing fencing and installation of 235 feet of new fencing to allow pedestrian access to the restored area
- installation of mulch walking paths through the restored area
- installation of one or more benches along the path
- installation of educational signage at multiple locations in the restored area
- removal of two small concrete structures from the decommissioned plant

I have met with a Glenbard North High School representative who teaches ecology courses and also works with the Green Panthers Club who has expressed interest in this opportunity to include students in the planning, design and monitoring of the project over several years. I have also spoken with CH2M and they have committed \$5,000 and expressed a desire to work closely with the Village and the high school in the planning and design efforts. While a project budget is still under development I would recommend that the Village commit \$5,000, and request a grant in the amount of \$10,000.

Grant applications are due by March 15 and must be accompanied by a resolution authorizing participation in the ComEd Green Region Program. Staff recommends Board adoption of the attached.

ComEd Green Region Grant

WRC East Side Open Space Conversion to Native Prairie Mix



Legend

- Existing Fence to Remain
- - - Existing Fence Removal
- Proposed Fence
- Village Property
- Native Prairie Area

RESOLUTION NO. _____

A RESOLUTION AUTHORIZING PARTICIPATION IN THE 2016 COMED GREEN REGION PROGRAM FOR THE WRC NATIVE PRAIRIE RESTORATION PROJECT

WHEREAS, the Village of Carol Stream (“Applicant”) desires to undertake the Native Prairie Restoration Project; and

WHEREAS, the Applicant desires to apply to the ComEd Green Region Program for a grant for the purpose of carrying out this project; and

WHEREAS, the Applicant has received and understands the 2016 ComEd Green Region Program Guidelines.

NOW, THEREFORE, BE IT RESOLVED BY THE MAYOR AND BOARD OF TRUSTEES OF THE VILLAGE OF CAROL STREAM, COUNTY OF DUPAGE, ILLINOIS, IN THE EXERCISE OF ITS HOME RULE POWERS, as follows:

SECTION 1: That the MAYOR AND BOARD OF TRUSTEES hereby approves this project and authorizes application to the ComEd Green Region Program in the amount of \$10,000.00; and,

SECTION 2: That the Applicant commits to the expenditure of matching funds in the amount of \$10,000.00 necessary for the project’s success.

SECTION 3: This Resolution shall be in full force and effect from and after its passage and approval as provided by law.

PASSED AND APPROVED this 7th day of March, 2016.

AYES:

NAYS:

ABSENT:

Frank Saverino, Sr., Mayor

ATTEST:

Laura Czarnecki, Village Clerk

RESOLUTION NO. _____

**A RESOLUTION AUTHORIZING THE EXECUTION OF THE
OFFICIAL ZONING MAP OF THE VILLAGE OF CAROL STREAM**

WHEREAS, the Illinois Compiled Statutes (65 ILCS 5/11-13-19) require the corporate authorities to publish a map clearly showing the zoning classification of all land within the municipality, including all changes that occurred within the preceding calendar year, no later than March 31 of each year; and

WHEREAS, at their meeting on February 22, 2016, the Combined Plan Commission and Zoning Board of Appeals reviewed and recommended approval of the 2016 Official Zoning Map for the Village of Carol Stream.

NOW, THEREFORE, BE IT RESOLVED BY THE MAYOR AND BOARD OF TRUSTEES OF THE VILLAGE OF CAROL STREAM, DU PAGE COUNTY, ILLINOIS, IN THE EXERCISE OF ITS HOME RULE POWERS, AS FOLLOWS:

SECTION 1: That the Mayor is authorized to execute and the Village Clerk to attest **The Official Zoning Map of the Village of Carol Stream**, a map prepared using base parcel data provided by the DuPage County Mapping Department, dated March 7, 2016, such document being attached to and made a part of this Resolution.

SECTION 2: This Resolution shall be in full force and effect from and after its passage and approval as provided by law.

PASSED AND APPROVED THIS 7th DAY OF MARCH 2016.

AYES:

NAYS:

ABSENT:

Frank Saverino, Sr., Mayor

ATTEST:

Laura Czarnecki, Village Clerk



Village of Carol Stream

Official Zoning Map

March 2016

LEGEND

- Residential Districts**
- R-1 One-Family Residence District
- R-2 One-Family Residence District
- R-3 One-Family Residence District
- R-4 One-Family Residence District
- Business Districts**
- B-1 Local Retail District
- B-2 General Retail District
- B-3 General Retail District
- B-4 Office, Research and Institutional Building District
- Industrial Districts**
- I-1 Industrial District
- I&D Research and Development
- Agricultural Districts**
- A-1 Agricultural District
- Overlay Districts**
- Corporate Limits
- Gay/North Ave Corridor Overlay District
- Planned Unit Development (PUD)**
- Properties designated as PUD base of all maps, subject to a PUD the through the Superior and ground.
- Neighboring Communities**
- Community Boundary
- Neighboring Communities

STATE OF ILLINOIS
COUNTY OF CLAY

THIS MAP CORRECTLY SHOWS THE ZONING OF THE VILLAGE OF CAROL STREAM, PASSED AND APPROVED ON:

March 7, 2016

Frank Sammarco, Jr.
MAYOR

ATTEST:

VILLAGE CLERK:



1 inch = 2,000 feet



Prepared by:
Community Development Department

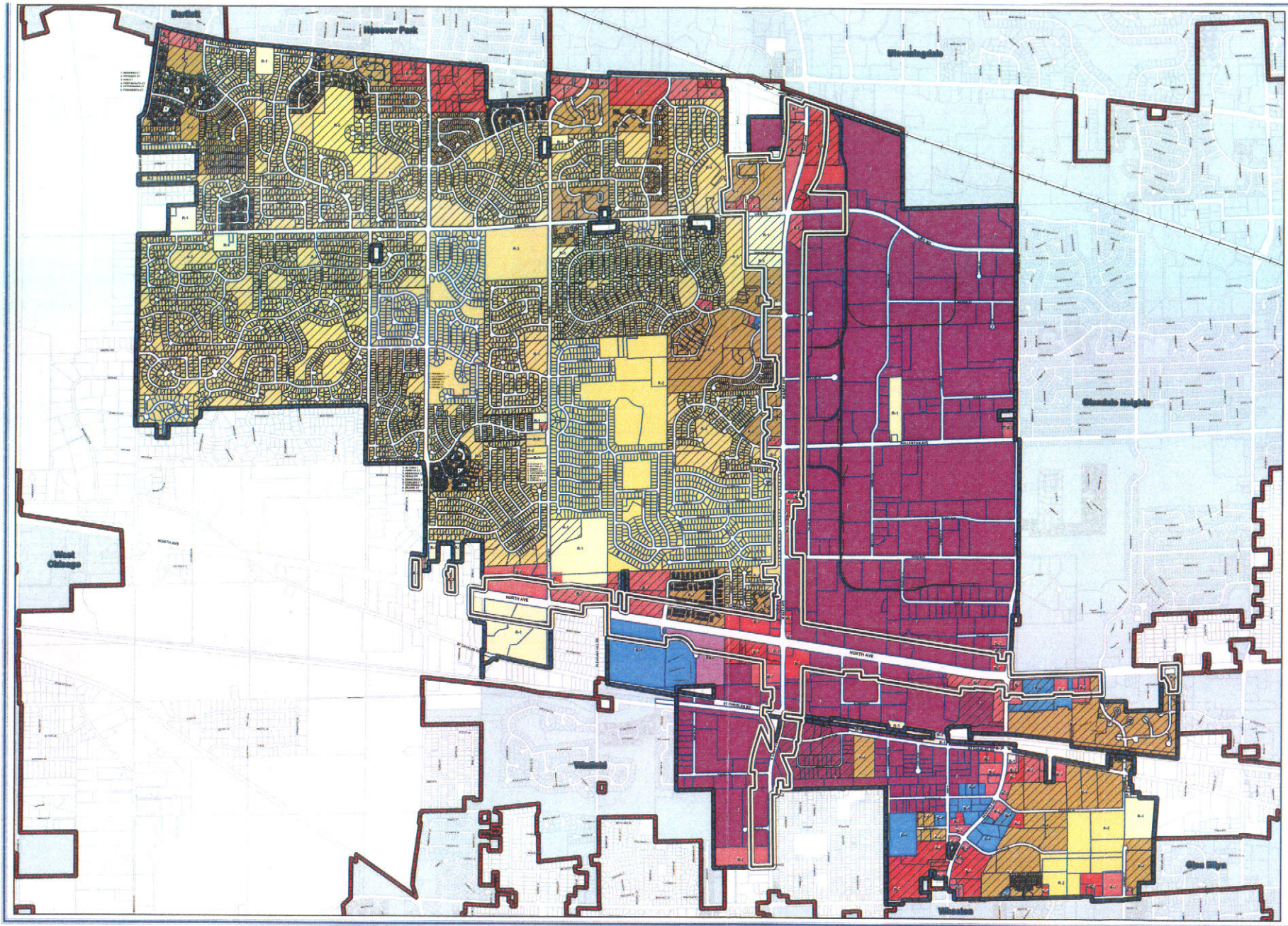

Village of Carol Stream
Interdepartmental Memo

TO: Joseph E. Breinig, Village Manager
FROM: Rose Armstrong, Administration Secretary *R*
DATE: February 17, 2016
RE: Carol Stream Historical Society
Raffle License Application

The Carol Stream Historical Society is sponsoring a Family Day at the Farmhouse and Quilt Raffle Drawing to be held on Saturday, September 10, 2016 at the Historic Farmhouse to benefit Historical Preservation. They have submitted a Class "B" raffle license application with the required manager's fidelity bond. Raffle tickets will be sold for 1 for \$1.00, 6 for \$5.00 and 25 for \$20.00 from February - September 10, 2016. The aggregate value of the raffle prizes total approximately \$800.

The raffle license application and required documentation is on file in the Village Clerk's office for your review.

Please place this item on the agenda for review and approval by the Village Board of Trustees at their upcoming Monday, March 7, 2016 meeting.

Thank you.

Attachment



Carol Stream Historical Society

Historic Farmhouse, 301 Lies Road, Carol Stream, IL
Mailing Address: P.O. Box 88791, Carol Stream, IL 60188-8791



February 10, 2016

Village of Carol Stream
500 Gary Avenue
Carol Stream, IL 60188

To Whom It May Concern;

The Carol Stream Historical Society hereby respectfully requests that the Village of Carol Stream waive the fees associated with Raffle Licensing and Application. The Society is a duly formed and registered Not For Profit Corporation.

Sincerely,

Carole Ellermeier, President

Preserve, Restore, Educate

www.CarolStreamHistorical.com

Village of Carol Stream
Interdepartmental Memo

TO: Robert Mellor, Assistant Village Manager
FROM: Rose Armstrong, Secretary 
DATE: February 24, 2016
RE: Corpus Christi Catholic Church
Raffle License Application

Corpus Christi Catholic Church has submitted a raffle license application for a raffle to be held at their St. Joseph Table event on Saturday, March 12, 2016 from 6:00 pm – 9:00 pm. Proceeds from this raffle will support the St. Vincent DePaul Society. The cost of the raffle tickets will be \$5.00 each or 3 for \$10.00.

Applicant is requesting a waiver of the application fee and the Manager's Fidelity Bond as indicated in the attached letter. The raffle license application and required documentation is on file in the Village Clerk's office for your review.

Please place this item on the agenda for review and approval by the Village Board of Trustees at their upcoming Monday, March 7, 2016 meeting.

Thank you.

Attachment

Joe Breinig

From: Kathie Brewer <cckbrewer@sbcglobal.net>
Sent: Tuesday, February 23, 2016 12:37 PM
To: Joe Breinig
Subject: raffle license fee

Dear Joe,

On March 12th Corpus Christi will be hosting our annual St. Joseph's Table. Monies raised at his event will be given to our St. Vincent DePaul Society which aids the needy in our area. The evening will include a 50/50 raffle. We have submitted the necessary forms to the Village to obtain a raffle license. At this time we are also requesting a waiver of the license fee. We appreciate any consideration of this request that the Village can offer our parish.

*Thanks and God be near you,
Kathie*

Kathie Brewer, Pastoral Associate

*Corpus Christi Church
1415 W. Lies Rd. Carol Stream, IL 60188 630-483-4673*

Village of Carol Stream
Interdepartmental Memo

TO: Joseph E. Breinig, Village Manager
FROM: Rose Armstrong 
DATE: February 29, 2016
RE: **Raffle License Request-Longfellow Elementary School PTA**

The Longfellow Elementary School PTA has submitted a raffle license application to hold a fundraising raffle at the American Legion Hall #76 on March 19, 2016. Ticket prices will be \$5.00 per ticket. The ticket sales and raffle will be held on March 19, 2016 at the American Legion Hall. The proceeds from this raffle will benefit the Longfellow Elementary School PTA.

Applicant is requesting a waiver of the application fee and the Manager's Fidelity Bond as indicated in the attached letter. The raffle license application and required documentation is on file in the Village Clerk's office for your review.

Please place this item on the agenda for review and approval by the Village Board of Trustees at their upcoming Monday, March 7, 2016 meeting.

Thank you.

Attachment

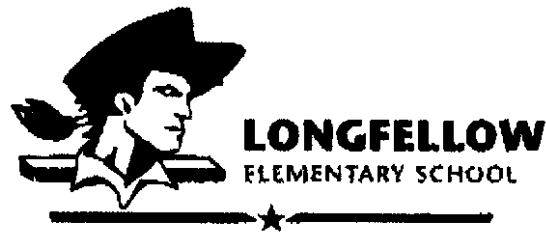

Longfellow Elementary School PTA 311 W. Seminary Ave. Wheaton, IL 60167

February 25, 2016

To whom it may concern,

We are hereby requesting a waiver of any fee or bond required in connection with our application for a raffle license. We are a non-profit, educational organization.

Thank you,

Kerry Mansour

Longfellow Elementary PTA President

Katie Kozlowski

Longfellow Elementary PTA Secretary

Village of Carol Stream
 Schedule of Bills
 For Village Board Approval on March 7, 2016

AGENDA ITEM
2-1 3-7-16

<u>Vendor / Description</u>	<u>Amount</u>	<u>Account Number</u>	<u>Account Description</u>	<u>Invoice No.</u>	<u>Purchase Order</u>
A T & T					
PD MNTHLY SRV 2/16 -3/15 2016	440.41	01652800-52230	TELEPHONE	630Z57651902 2/16/16	
	<u>440.41</u>				
ABBOTT TREE CARE					
SNOW REMOVAL 2/9 & 2/14	3,415.79	01670200-52266	SNOW REMOVAL	36945	
	<u>3,415.79</u>				
AJD CONCRETE CONSTRUCTION CORP					
SIDEWALK PILOT PRGM 1/12/16	589.00	01670200-52266	SNOW REMOVAL	2016-125	
SIDEWALK PILOT PRGM 2/24/16	380.00	01670200-52266	SNOW REMOVAL	2016-167	
SIDEWALK PILOT PRGM 02/14 & 02/15	817.00	01670200-52266	SNOW REMOVAL	2016-157	
SIDEWALK PILOT PRGM 03/01/16	665.00	01670200-52266	SNOW REMOVAL	2016-173	
SIDEWALK PILOT PRGM 03/01/16	665.00	01670200-52266	SNOW REMOVAL	2016-174	
SNOW REMOVAL 1/9 & 1/10	3,063.45	01670200-52266	SNOW REMOVAL	2016-107	
SNOW REMOVAL 02/14 & 02/15	5,037.30	01670200-52266	SNOW REMOVAL	2016-158	
SNOW REMOVAL 1/11 & 1/12	3,832.06	01670200-52266	SNOW REMOVAL	2016-122	
SNOW REMOVAL 1/11/16	96.95	01670200-52266	SNOW REMOVAL	2016-127	
SNOW REMOVAL 1/11/16	334.95	01670200-52266	SNOW REMOVAL	2016-124	
SNOW REMOVAL 1/12/16	85.00	01670200-52266	SNOW REMOVAL	2016-128	
SNOW REMOVAL 1/12/16	168.90	01670200-52266	SNOW REMOVAL	2016-123	
SNOW REMOVAL 1/12/16	228.00	01670200-52266	SNOW REMOVAL	2016-126	
SNOW REMOVAL 1/14 & 2/14	454.93	01670200-52266	SNOW REMOVAL	2016-156	
SNOW REMOVAL 2/17/16	589.00	01670200-52266	SNOW REMOVAL	2016-161	
	<u>17,006.54</u>				
AVI SYSTEMS INC					
CATV ROOM UPGRADES	3,657.00	01520000-54418	CATV/ PEG EXPENSES	88406387	
	<u>3,657.00</u>				

**Village of Carol Stream
Schedule of Bills
For Village Board Approval on March 7, 2016**

<u>Vendor / Description</u>	<u>Amount</u>	<u>Account Number</u>	<u>Account Description</u>	<u>Invoice No.</u>	<u>Purchase Order</u>
B & F CONSTRUCTION CODE SERVICES, INC					
FIRE ALARM 171 W ST CHARLES RD	1,609.45	01643700-52253	CONSULTANT	43412	
PLUMBING INSP'S JAN/16	644.80	01643700-52253	CONSULTANT	43385	
	<u>2,254.25</u>				
BRANCATO LANDSCAPING					
SNOW REMOVAL 2/14/16	1,048.25	01670200-52266	SNOW REMOVAL	2751	
	<u>1,048.25</u>				
BUILDING & FIRE CODE ACADEMY					
SEMINAR 2/29- 3/1 MILSCHEWSKI	345.00	01643700-52223	TRAINING	49399	
	<u>345.00</u>				
C J INCROCCI					
EXC MGMT PRGM NWU-EVANSTON	3,360.00	01662700-52223	TRAINING	PER DIEM 3/14-5/20	
	<u>3,360.00</u>				
C S FIRE PROTECTION DISTRICT					
PERMITS - JANUARY 2016	520.00	01-24416	DEPOSIT-FIRE DISTRICT PERMIT	PERMITS JAN/16	
	<u>520.00</u>				
CHRISTMAS SHARING PROGRAM					
CHRISTMAS SHARING DONATIONS	3,459.54	01-24223	CHRISTMAS SHARING	2015/16 DONATIONS	
	<u>3,459.54</u>				
CHRISTOPHER B BURKE ENGR LTD					
PROF SRV'S JAN/16 - 1 MERCEDES DR PDC BLDG	9,520.50	01620600-52253	CONSULTANT	127560	
	<u>9,520.50</u>				
CITY COMMUNICATIONS INC					
FIRE ALARM SERVICE CALL/LABOR	252.50	01670400-52244	MAINTENANCE & REPAIR	32238	
	<u>252.50</u>				

**Village of Carol Stream
 Schedule of Bills
 For Village Board Approval on March 7, 2016**

<u>Vendor / Description</u>	<u>Amount</u>	<u>Account Number</u>	<u>Account Description</u>	<u>Invoice No.</u>	<u>Purchase Order</u>
COMCAST CABLE					
CABLE TV 02/26 - 03/25	4.23	01652800-52234	DUES & SUBSCRIPTIONS	0113254 2/19/16	
INTERNET SERVICE MARCH/2016	104.90	01652800-52234	DUES & SUBSCRIPTIONS	0010112 2/20/16	
	<u>109.13</u>				

**Village of Carol Stream
Schedule of Bills
For Village Board Approval on March 7, 2016**

<u>Vendor / Description</u>	<u>Amount</u>	<u>Account Number</u>	<u>Account Description</u>	<u>Invoice No.</u>	<u>Purchase Order</u>
COMED					
100 DELLA CT JAN/16	21.08	01670300-53213	STREET LIGHT ELECTRICITY	1083101009 2/11/16	
1015 W LIES RD TOWER #4	65.83	04201600-53210	ELECTRICITY	2514004009 2/18/16	
1025 LIES RD - CONTROLLER	309.00	01670300-53213	STREET LIGHT ELECTRICITY	6213120002 02/18/16	
106 GOLDENHILL	30.01	01670600-53210	ELECTRICITY	2127117053 02/24/16	
110 E ST CHARLES JAN/16	30.77	01670600-53210	ELECTRICITY	6827721000 02/10/16	
1128 EVERGREEN TRL	93.07	04101500-53210	ELECTRICITY	0291093117 02/22/16	
1345 GEORGETOWN CONTROLLER	27.45	01670300-53213	STREET LIGHT ELECTRICITY	1603109101 02/23/16	
1348 CHARGER CT	543.15	04101500-53210	ELECTRICITY	2496057000 2/18/16	
1350 TALL OAKS STATION	50.24	04101500-53210	ELECTRICITY	2073133107 02/19/16	
1415 MAPLE RIDGE CT	30.01	01670600-53210	ELECTRICITY	5838596003 02/22/16	
301 ANTELOPE TRL	72.94	01670300-53213	STREET LIGHT ELECTRICITY	0801065136 02/19/16	
333 FULLERTON, WELL 3	1,171.52	04201600-53210	ELECTRICITY	0300009027 02/19/16	
391 FLINT TRAIL	58.04	01670300-53213	STREET LIGHT ELECTRICITY	2207156029 02/19/16	
391 ILLINI DR	147.10	01670600-53210	ELECTRICITY	4430145023 02/19/16	
403 SIOUX -STR LIGHTS	24.75	01670300-53213	STREET LIGHT ELECTRICITY	1353117013 02/22/16	
451 SILVERLEAF - LIGHTS	47.87	01670300-53213	STREET LIGHT ELECTRICITY	0030086009 02/19/16	
491 CHEYENNE DR	24.50	01670300-53213	STREET LIGHT ELECTRICITY	6597112015 02/22/16	
500 N GARY - CONTROLLER	87.35	01670300-53213	STREET LIGHT ELECTRICITY	6675448009 02/18/16	
506 CHEROKEE JAN/16	54.15	01670300-53213	STREET LIGHT ELECTRICITY	3153036011 2/19/16	
512 CANYON TRL	22.09	01670300-53213	STREET LIGHT ELECTRICITY	1043062112 02/22/16	
594 NEX PERCE CT	63.79	01670300-53213	STREET LIGHT ELECTRICITY	0975048036 02/22/16	
850 LONGMEADOW	19.61	01670600-53210	ELECTRICITY	1865134015 02/19/16	
867 SHENANDOAH JAN/16	19.61	01670600-53210	ELECTRICITY	4483019016 2/19/16	
879 DORCHESTER JAN/16	19.61	01670600-53210	ELECTRICITY	0803155026 02/19/16	
880 PAPOOSE CT	132.32	01670300-53213	STREET LIGHT ELECTRICITY	0822115042 2/19/16	
990 DEARBORN CIR	67.10	01670300-53213	STREET LIGHT ELECTRICITY	3480136046 02/19/16	
END THORNHILL (COMM PARK)	131.81	01670600-53210	ELECTRICITY	6337409002 2/18/2016	
MASTER ACCOUNT FEB/16	956.23	01670300-53213	STREET LIGHT ELECTRICITY	5853045025 02/23/16	
RED LIGHT CAMERA KUHN RD	37.83	01662300-52298	ATLE SERVICE FEE	4202129060 02/19/16	
SW MORTON/LIES MASTER 12/29 -2/29	184.68	01670300-53213	STREET LIGHT ELECTRICITY	0815164035 2/29/16	

**Village of Carol Stream
Schedule of Bills
For Village Board Approval on March 7, 2016**

<u>Vendor / Description</u>	<u>Amount</u>	<u>Account Number</u>	<u>Account Description</u>	<u>Invoice No.</u>	<u>Purchase Order</u>
	<u>4,543.51</u>				
CONCEPT WIRELESS COMMUNICATIONS INC					
RADIOS FOR #47 & #84 TRUCKS	256.06	01670200-53317	OPERATING SUPPLIES	159058	
	<u>256.06</u>				
CONSTELLATION NEW ENERGY					
200 TUBEWAY LFT STN 1/11 - 2/9	326.85	04101500-53210	ELECTRICITY	00307225080001	
	<u>326.85</u>				
COOK COUNTY CLERK'S OFFICE					
COMM REGIS RNWL 2/17/16-2/17/20 G HARKER	10.00	01662700-52234	DUES & SUBSCRIPTIONS	GLENN HARKER	
	<u>10.00</u>				
COSTCO WHOLESALE					
VENDING MACHINE PRODUCTS FEB/2016	241.40	01590000-53380	VENDING MACHINE SUPPLIES	074487	
	<u>241.40</u>				
CRYSTAL MGMT & MAINTENANCE SRV'S CORP					
CLEANING SERVICES MARCH	860.00	01670100-52276	JANITORIAL SERVICES	23534	
CLEANING SERVICES MARCH	1,385.00	01680000-52276	JANITORIAL SERVICES	23534	
	<u>2,245.00</u>				
DUPAGE COUNTY CLERK					
NOTARY COMM RNWL ROBYN DIECKMANN	10.00	01662600-52234	DUES & SUBSCRIPTIONS	R DIECKMANN	
	<u>10.00</u>				
DUPAGE COUNTY DIVISION OF TRANSPORTATION					
ROAD CLOSURE PERMIT FEE -4TH OF JULY	50.00	01750000-52291	MISC EVENTS/ACTIVITIES	4TH OF JULY PERMIT	
	<u>50.00</u>				
DUPAGE MAYORS AND MANAGERS CONFERENCE					
MONTHLY MTG JAN /16 BREINIG	55.00	01590000-52222	MEETINGS	9298	
	<u>55.00</u>				

**Village of Carol Stream
Schedule of Bills
For Village Board Approval on March 7, 2016**

<u>Vendor / Description</u>	<u>Amount</u>	<u>Account Number</u>	<u>Account Description</u>	<u>Invoice No.</u>	<u>Purchase Order</u>
DUPAGE SENIOR CITIZEN COUNCIL					
FY16 SENIOR COUNCIL CONTRIBUTION	8,400.00	01520000-52274	COMMUNITY SERVICE PROGRAMS	2/18/2014	
	<u>8,400.00</u>				
DUPAGE WATER COMMISSION					
OPER/MTC JAN/2016	448,552.25	04201600-52283	DUPAGE CTY WATER COMMISSION	11183	
	<u>448,552.25</u>				
EMERSON MANUFACTURING					
HINGE LOCKS	653.00	01670200-53317	OPERATING SUPPLIES	22900	
	<u>653.00</u>				
FOURTH OF JULY PARADE COMMITTEE					
PARADE DONATIONS	1,893.49	01-24224	JULY 4TH DONATIONS		PARADE DONATIONS
	<u>1,893.49</u>				
GAS DEPOT					
DIESEL FUEL	8,319.00	01696200-53356	GAS PURCHASED	25635	
	<u>8,319.00</u>				
GLENN STEINHOFER					
SNOW REMOVAL 2/14/16	3,639.96	01670200-52266	SNOW REMOVAL	SS155	
	<u>3,639.96</u>				
GOVTEMPSUSA LLC					
OFFICE MGR W/E 02/07	1,419.20	01590000-52253	CONSULTANT	1909731	
OFFICE MGR W/E 02/14	1,419.20	01590000-52253	CONSULTANT	1909732	
TEMP SECR COM DV W/E 02/07	1,232.00	01643700-52253	CONSULTANT	1909733	
TEMP SECR COM DV W/E 02/14	985.60	01643700-52253	CONSULTANT	1909734	
	<u>5,056.00</u>				
H & H ELECTRIC COMPANY					
METER INSTALL	968.00	01670300-52271	STREET LIGHT MAINTENANCE	25310	
	<u>968.00</u>				

**Village of Carol Stream
Schedule of Bills
For Village Board Approval on March 7, 2016**

<u>Vendor / Description</u>	<u>Amount</u>	<u>Account Number</u>	<u>Account Description</u>	<u>Invoice No.</u>	<u>Purchase Order</u>
HENDERSON TRUCK EQUIPMENT					
TRUCK #40 OUTFITTING OF A FORD F-550	50,250.00	01670200-54415	VEHICLES	J8-01256	
	<u>50,250.00</u>				
HYDROAIRE SERVICE INC					
3RD PUMP RPR INSTALL AT CHARGER	5,497.00	04101500-52244	MAINTENANCE & REPAIR	8060	
REBUILDING 2ND PUMP-CHARGER LIFT STN	4,518.00	04101500-52244	MAINTENANCE & REPAIR	8058	
REMOVE PUMP AND INSTL CHARGER CT	5,717.00	04101500-52244	MAINTENANCE & REPAIR	8061	
	<u>15,732.00</u>				
ILLINOIS CITY COUNTY MANAGEMENT ASSN					
AD FOR UTILITIES SUPERVISOR	50.00	01600000-52228	PERSONNEL HIRING	359	
	<u>50.00</u>				
ILLINOIS MUNICIPAL LEAGUE					
AD FOR UTILITIES SUPERVISOR	35.00	01600000-52228	PERSONNEL HIRING	0027701-IN	
	<u>35.00</u>				
ILLINOIS POWER MARKETING					
300 BENNETT DR - LIGHTS	2,458.73	01670300-53213	STREET LIGHT ELECTRICITY	105438416021 2/25/16	
	<u>2,458.73</u>				
JOHN C BOSCO					
SNOW PLOWING 2/9/16	174.39	01670200-52266	SNOW REMOVAL	15604	
SNOW REMOVAL 2/14/16	228.35	01670200-52266	SNOW REMOVAL	15605	
	<u>402.74</u>				
JOHN L FIOTI					
LOCAL PROSCECUTION - FEB/16	225.00	01570000-52238	LEGAL FEES	C S 86	
LOCAL PROSCECUTION - FEB/16	225.00	01662300-52310	ATLE LEGAL ADJUDICATION	C S 86	
	<u>450.00</u>				

**Village of Carol Stream
Schedule of Bills
For Village Board Approval on March 7, 2016**

<u>Vendor / Description</u>	<u>Amount</u>	<u>Account Number</u>	<u>Account Description</u>	<u>Invoice No.</u>	<u>Purchase Order</u>
JX ENTERPRISES INC					
TRUCK #67 PURCHASE	177,446.38	01670200-54415	VEHICLES	3453	
	<u>177,446.38</u>				
K TECH SPECIALTY COATINGS INC					
SNOW OPERATIONS BEET HEET CONCENTRATE	6,296.19	01670200-53335	SALT	201602-K0010	
	<u>6,296.19</u>				
KLEIN, THORPE & JENKINS, LTD					
GENERAL COUNSEL - JAN/2016	307.50	04200100-52238	LEGAL FEES	180970 2/18/16	
GENERAL COUNSEL - JAN/2016	492.00	04100100-52238	LEGAL FEES	180970 2/18/16	
GENERAL COUNSEL - JAN/2016	820.00	01510000-52238	LEGAL FEES	180970 2/18/16	
GENERAL COUNSEL - JAN/2016	2,152.50	11740000-52238	LEGAL FEES	180970 2/18/16	
GENERAL COUNSEL - JAN/2016	8,662.17	01570000-52238	LEGAL FEES	180970 2/18/16	
	<u>12,434.17</u>				
LEONARD M BULAT					
INSTALL POLICE STRIPE #625	265.00	01662700-52244	MAINTENANCE & REPAIR	16-134	
	<u>265.00</u>				
MENDEL PLUMBING & HEATING INC					
PULLDOWN 1 FURNACE & CAP	315.00	01696200-52244	MAINTENANCE & REPAIR	W32094	
REMOVAL & CAPPED UNUSED FURNACE	217.50	01696200-52244	MAINTENANCE & REPAIR	W31370	
REPLACE 5 FURNACES IN MECH. GARAGE	10,975.00	01696200-52244	MAINTENANCE & REPAIR	W31977	
	<u>11,507.50</u>				
METROPOLITAN INDUSTRIES INC					
SEALER IMPELLER & WEARING 3RD PUMP CHR	3,570.00	04101500-52244	MAINTENANCE & REPAIR	307075	
SPARE PUMPS LIFT STATIONS	6,535.00	04101500-52244	MAINTENANCE & REPAIR	306965	20160032
	<u>10,105.00</u>				

**Village of Carol Stream
Schedule of Bills
For Village Board Approval on March 7, 2016**

<u>Vendor / Description</u>	<u>Amount</u>	<u>Account Number</u>	<u>Account Description</u>	<u>Invoice No.</u>	<u>Purchase Order</u>
MORTON SALT INC					
SALT PURCHASE THRU DUPG CO	23,750.96	01670200-53335	SALT	5401011455	20160021
	<u>23,750.96</u>				
MOTOROLA SOLUTIONS INC					
NW RADIO FOR SQUAD #652	1,952.23	01662700-53350	SMALL EQUIPMENT EXPENSE	13100001	
	<u>1,952.23</u>				
MR SITCO					
METER READINGS - MARCH	1,776.00	04103100-52221	UTILITY BILL PROCESSING	2016006	
METER READINGS - MARCH	1,776.00	04203100-52221	UTILITY BILL PROCESSING	2016006	
	<u>3,552.00</u>				
NICOR					
CHARGER CT FEB/16	84.86	04101500-53230	NATURAL GAS	86606011178 2/10/16	
TUBEWAY DR 1/27 - 2/26	25.96	04101500-53230	NATURAL GAS	14309470202 2/19/16	
WELL #4 01/08- 02/05	116.75	04201600-53230	NATURAL GAS	13811210007 2/8/16	
	<u>227.57</u>				
NMI					
CC GATEWAY FEES FEB/2016	74.30	04103100-52221	UTILITY BILL PROCESSING	255365017	
CC GATEWAY FEES FEB/2016	74.30	04203100-52221	UTILITY BILL PROCESSING	255365017	
	<u>148.60</u>				
NORTHWEST POLICE ACADEMY					
SAILER, HOFFMAN & JUNGERS SEMINAR	75.00	01660100-52222	MEETINGS	2/11/2016 SEMINAR	
	<u>75.00</u>				
NORTHWESTERN UNIVERSITY					
HOTEL FOR EXC MGMT PROGM 3/14 - 5/20	4,780.00	01662700-52223	TRAINING	HOTEL -CJ INCROCCI	
	<u>4,780.00</u>				

**Village of Carol Stream
Schedule of Bills
For Village Board Approval on March 7, 2016**

<u>Vendor / Description</u>	<u>Amount</u>	<u>Account Number</u>	<u>Account Description</u>	<u>Invoice No.</u>	<u>Purchase Order</u>
PERSPECTIVES					
EAP QTRLY 3/1 -5/31	1,149.72	01600000-52273	EMPLOYEE SERVICES	83151	
	<u>1,149.72</u>				
REFUNDS MISC					
BUSINESS LIC REFUND	12.50	01000000-42301	BUSINESS/MISC LICENSES	200 S SCHMALE	
OVERPAID ON RENTAL LICENSE	25.00	01000000-42309	RENTAL LICENSING PROGRAM	134 KLEIN CREEK #2B	
	<u>37.50</u>				
REFUNDS TAX STAMPS					
TAX STAMP #27440 REFUND	630.00	01000000-41208	REAL ESTATE TRANSFER TAX	584 COMMANCHE	
	<u>630.00</u>				
RUSH TRUCK CENTERS					
COVER ASM BATTERY BOX	131.84	01696200-53354	PARTS PURCHASED	3001575213	
FUEL FILTER PARTS/LABOR	555.23	01696200-53353	OUTSOURCING SERVICES	3001560716	
	<u>687.07</u>				
SAUBER MGF.CO					
TOOL BOXES	2,450.00	01670500-54412	OTHER EQUIPMENT	PSI173335	
	<u>2,450.00</u>				
SIERRA SYSTEMS INC					
IT CONTRACTOR W/E 12/05/15	2,120.00	01652800-52253	CONSULTANT	1805967	
IT CONTRACTOR W/E 12/12/15	1,696.00	01652800-52253	CONSULTANT	1805959	
	<u>3,816.00</u>				
SIMPLEX GRINNELL					
GAUGES & INSPECTION FIRE SYSTEM	985.00	01670400-52244	MAINTENANCE & REPAIR	82225737	20160033
GAUGES & INSPECTION FIRE SYSTEM	2,565.00	01670400-52244	MAINTENANCE & REPAIR	82224875	20160033
	<u>3,550.00</u>				

**Village of Carol Stream
Schedule of Bills
For Village Board Approval on March 7, 2016**

<u>Vendor / Description</u>	<u>Amount</u>	<u>Account Number</u>	<u>Account Description</u>	<u>Invoice No.</u>	<u>Purchase Order</u>
TELVENT DTN INC					
WEATHER SRV FRM 3/22/16-3/21/17	2,376.00	01670100-52234	DUES & SUBSCRIPTIONS	4802462	
	2,376.00				
THE DAVENPORT GROUP					
PERMIT SOFTWARE	8,674.00	01643700-52255	SOFTWARE MAINTENANCE	1601-ILCS-01	20160029
	8,674.00				
THIRD MILLENIUUM ASSOCIATES INCORPORATED					
E-PAY SERVER FEE FEB/16	225.00	04103100-52221	UTILITY BILL PROCESSING	19106	
E-PAY SERVER FEE FEB/16	225.00	04203100-52221	UTILITY BILL PROCESSING	19106	
WTR BILL PRINTING 2/29/16	1,312.97	04103100-52221	UTILITY BILL PROCESSING	19109	
WTR BILL PRINTING 2/29/16	1,312.97	04203100-52221	UTILITY BILL PROCESSING	19109	
	3,075.94				
THOMAS DODGE CHRYSLER JEEP					
2- 2015 DODGE DURANGO SQUAD CARS	62,764.00	01662700-54415	VEHICLES	2 -2015 DODGE	
	62,764.00				
TIM'S AUTO BODY					
REPAIR TO REAR D/S DOOR	687.00	01662700-52244	MAINTENANCE & REPAIR	4163	
	687.00				
TRANSYSTEMS CORPORATION					
KUHN RD BIKE EXT-PH I ENGR CONT 10/30- 02/1	2,817.24	11740000-55486	ROADWAY CAPITAL IMPROVEMENT	01-2923800	20160031
PH I LIES RD BIKE TRL EXT-10/30 02/12	1,469.60	11740000-55486	ROADWAY CAPITAL IMPROVEMENT	01-2923804	20160030
	4,286.84				
TRI RIVER POLICE TRAINING REGION, INC					
TRNG COOPER, STAFIEJ & CLUEVER 1/14/16	210.00	01662300-52223	TRAINING	3875	
	210.00				

**Village of Carol Stream
Schedule of Bills
For Village Board Approval on March 7, 2016**

<u>Vendor / Description</u>	<u>Amount</u>	<u>Account Number</u>	<u>Account Description</u>	<u>Invoice No.</u>	<u>Purchase Order</u>
U S POSTMASTER					
POSTAGE 2/26/16 WTR BILLS	2,281.39	04203100-52229	POSTAGE	INV 1529 02/26/16	
POSTAGE 2/26/16 WTR BILLS	2,281.40	04103100-52229	POSTAGE	INV 1529 02/26/16	
	<u>4,562.79</u>				
US WILDLIFE REMOVAL					
STORM FLOW OBSTRUCTION PREVENTION	470.00	01670600-52244	MAINTENANCE & REPAIR	340	
	<u>470.00</u>				

**Village of Carol Stream
Schedule of Bills
For Village Board Approval on March 7, 2016**

<u>Vendor / Description</u>	<u>Amount</u>	<u>Account Number</u>	<u>Account Description</u>	<u>Invoice No.</u>	<u>Purchase Order</u>
VERIZON WIRELESS					
SERV FOR JAN 14- FEB 13	-150.00	01652800-52230	TELEPHONE	9760501940	
SERV FOR JAN 14- FEB 13	1.23	01662700-52230	TELEPHONE	9760501940	
SERV FOR JAN 14- FEB 13	18.08	01642100-52230	TELEPHONE	9760501940	
SERV FOR JAN 14- FEB 13	18.08	01662500-52230	TELEPHONE	9760501940	
SERV FOR JAN 14- FEB 13	59.91	01610100-52230	TELEPHONE	9760501940	
SERV FOR JAN 14- FEB 13	59.91	01690100-52230	TELEPHONE	9760501940	
SERV FOR JAN 14- FEB 13	68.01	01590000-52230	TELEPHONE	9760501940	
SERV FOR JAN 14- FEB 13	77.99	01680000-52230	TELEPHONE	9760501940	
SERV FOR JAN 14- FEB 13	97.92	01600000-52230	TELEPHONE	9760501940	
SERV FOR JAN 14- FEB 13	114.15	04101500-52230	TELEPHONE	9760501940	
SERV FOR JAN 14- FEB 13	114.15	04201600-52230	TELEPHONE	9760501940	
SERV FOR JAN 14- FEB 13	122.05	01662300-52230	TELEPHONE	9760501940	
SERV FOR JAN 14- FEB 13	132.30	01643700-52230	TELEPHONE	9760501940	
SERV FOR JAN 14- FEB 13	135.93	04200100-52230	TELEPHONE	9760501940	
SERV FOR JAN 14- FEB 13	181.11	01590000-52230	TELEPHONE	9760501940	
SERV FOR JAN 14- FEB 13	299.55	01662400-52230	TELEPHONE	9760501940	
SERV FOR JAN 14- FEB 13	336.21	01620100-52230	TELEPHONE	9760501940	
SERV FOR JAN 14- FEB 13	359.46	01664700-52230	TELEPHONE	9760501940	
SERV FOR JAN 14- FEB 13	404.35	01670100-52230	TELEPHONE	9760501940	
SERV FOR JAN 14- FEB 13	415.13	01652800-52230	TELEPHONE	9760501940	
SERV FOR JAN 14- FEB 13	461.15	01660100-52230	TELEPHONE	9760501940	
SERV FOR JAN 14- FEB 13	1,708.43	01662700-52230	TELEPHONE	9760501940	
	5,035.10				
VIDEO AND SOUND SERVICE INC					
CAMERA REPAIR	440.00	01652800-52253	CONSULTANT	82797	
	440.00				

**Village of Carol Stream
Schedule of Bills
For Village Board Approval on March 7, 2016**

<u>Vendor / Description</u>	<u>Amount</u>	<u>Account Number</u>	<u>Account Description</u>	<u>Invoice No.</u>	<u>Purchase Order</u>
VILLAGE OF CAROL STREAM					
245 KUHN RD CONTL BLDG 01/08 -02/05	7.19	04101500-53220	WATER	01053543/20871	
245 N KUHN RD 01/09 -02/05	30.34	04101500-53220	WATER	01053544/20872	
CS PWKS CTR 01/06-02/05	82.25	01670100-53220	WATER	01053547/20875	
N GARAGE 01/06 - 02/05	291.86	01670100-53220	WATER	01053546/20874	
TC VISITOR CTR 1/8 - 2/6	5.31	01680000-53220	WATER	01053550/20878	
VILLAGE HALL 1/9 -2/6	238.86	01680000-53220	WATER	01053548/20876	
	<u>655.81</u>				
WHEATON BANK AND TRUST					
WHEATON BANK FEES JAN/16	362.89	04103100-52256	BANKING SERVICES	7509063 JAN/16	
WHEATON BANK FEES JAN/16	362.89	04203100-52256	BANKING SERVICES	7509063 JAN/16	
WHEATON BANK FEES JAN/16	1,244.84	01610100-52256	BANKING SERVICES	7509063 JAN/16	
	<u>1,970.62</u>				
WORD SYSTEMS INC					
I RECORD/AUDIO SYSTEM CONTR 4/01/2016-3/3	1,329.57	01662400-52255	SOFTWARE MAINTENANCE	IN15349	
	<u>1,329.57</u>				
ZONES INC					
ZONES REBATE PAYMENT	130,194.80	01720000-58207	ZONES SALES TAX REIMB	REBATE PAYMENT	
	<u>130,194.80</u>				
GRAND TOTAL	<u><u>\$1,091,580.26</u></u>				

The preceding list of bills payable totaling \$1,094,016.76 was reviewed and approved for payment.

Approved by:



Joseph Breinig - Village Manager

Date: _____

3/4/16

Authorized by:

Frank Saverino Sr – Mayor

Laura Czarnecki- Village Clerk

ADDENDUM WARRANTS
February 17, 2016 thru March 7, 2016

Fund	Check #	Vendor	Description	Amount
General	A C H	Wheaton Bank & Trust	Payroll Feb 1, 2015 thru Feb 14, 2016	500,376.34
Water & Sewer	A C H	Wheaton Bank & Trust	Payroll Feb 1, 2015 thru Feb 14, 2016	39,511.89
General	A C H	Wheaton Bank & Trust	Payroll Feb 15, 2015 thru Feb 28, 2016	484,370.07
Water & Sewer	A C H	Wheaton Bank & Trust	Payroll Feb 15, 2015 thru Feb 28, 2016	<u>39,582.11</u>
				<u><u>1,063,840.41</u></u>

Approved this _____ day of _____, 2016

By: _____
 Frank Saverino Sr - Mayor

 Laura Czarnecki - Village Clerk